

# NUAIRE

## AXR

### Roof mounted Axial for Smoke Control

# Installation and Maintenance

## NUAIRE

NuAire Limited  
Western Industrial Estate, Caerphilly,  
CF83 1XH United Kingdom  
Tel: 029 2088 5911  
Fax: 029 2088 7033  
Email: info @ nuaire. co.uk  
www.nuaire.co.uk

Leaflet No. 671063

AUGUST 2000

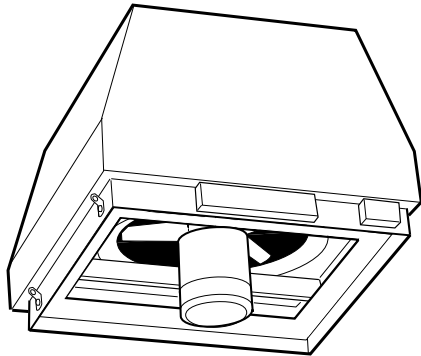

Fig. 1 AXR Roof mounted axial 300°C and 400°C

### Description

The NuAire AXR Roof mounted unit is designed to operate day to day as standard roof extract fan. However, in the event of a fire, the unit can extract smoke at temperatures up to 400°C for a maximum of two hours. The fans have airflow rates up to 23m<sup>3</sup>/s and static pressure up to 555Pa

#### The unit is available in four case sizes:

AXR 560, AXR 710, AXR 1000, AXR 1250

(See page 3 for dimensions and weights). The 560 and 710 units are manufactured in aluminium alloy. 1000 to 1250 size units are manufactured in polyester powder painted galvanised steel.

All units have airflow operated shutters which are weather proof when closed. The bird/ safety guards on the outlet are designed to automatically displace if blocked by fire debris etc.

The fans incorporate a directly driven, high performance, temperature rated, form 'A' aluminium alloy (300°C) and steel (400°C) axial flow type impellers.

Access to the impeller/motor is made by removing the top cover assembly.

### Motors

Motors comply with BS5000 and IRC34-1; they have sealed for life ball bearings, IP55 enclosures and class H insulation. Motors are tested for high temperature operation in accordance with BS7346 (Part 2) and PR EN 12101-3.

### Wiring

Electrical supply wiring connection is direct to a terminal box on the outside of the case. The box is pre-wired to the motor with heat resisting cable.

#### NOTE: We recommend D.O.L. starting whenever possible.

Units of 4kW and above have provision for Star/Delta starting if this is required (and is permitted by the relevant authorities).

Two speed motors must be wired for D.O.L. starting only.

Two speed motors, allowing normal ventilation at reduced noise levels, are available on all units.

### Contents

<b>Description</b>	<b>1</b>
<b>Handling</b>	<b>2</b>
<b>Dimensions</b>	<b>2</b>
<b>Installation / Curb details</b>	<b>3</b>
<b>Motor Details</b>	<b>4</b>
<b>Testing</b>	<b>5</b>
<b>Wiring Diagrams</b>	<b>5</b>
<b>Maintenance</b>	<b>6</b>
<b>Certification</b>	<b>7</b>

### Warning - Danger

This equipment incorporates rotating and moving parts as well as electrical components and conductors. It is the responsibility of the installer to ensure that any such items that remain externally accessible once the equipment is installed are adequately guarded.

This precaution is necessary to avoid the possibility of accidental injury or death. Particular attention must be paid to the inlet side of rotating impellers.

### Coding example

**AXR 100 - 4 1 3 A 7 T**

↓ ↓ ↓ ↓ ↓ ↓ ↓ ↓

**1 2 3 4 5 6 7 8**

- 1** AXUS roof mounted axial fan
- 2** Impeller diameter in mm
- 3** Motor speed in poles
- 4** Performance Curve number
- 5** Electrical supply in phases  
3 = 400V, 50Hz
- 6** Impeller material  
A = Aluminium alloy  
S = Steel (mandatory for 400°C units)
- 7** Operating temperature  
7 = 300°C for 1 hour  
8 = 400°C for 2 hours
- 8** Other options (combinations possible)  
T = Two speed (full and half)  
T6 = Two speed (full and two thirds)  
(4/6 pole only)  
F = Flameproof (Exd 11BT4) (300°C only)

### General

Units are delivered to site mounted onto wooden transit frames. In addition to making the fans easier to handle during transit, the frames also afford protection for the motor section. We advise that the wooden frames should remain on the fans until the moment of actual installation and fixing.

**Handling**

Handling the unit is best carried out with the unit fixed to the transit frame. When lifting, use spreader beams through the transit frame ensuring the unit is evenly balanced and that the lifting slings or webbing are not in direct contact with the casing. Larger unit (1250) has lifting lugs fitted to each lower corner to which the slings can be attached which makes the use of spreaders unnecessary. See figure 2a.

A typical lifting arrangement for a unit is shown in figure 2b. Note. When releasing a larger unit from its metal transit frame the weight of the unit should first be supported by jacks under the unit motor supports before attempting to remove the frame fixing screws. (See fig 2c).

1000 & 1250 units are supplied with eyelets bolted to the cowl, THESE ARE ONLY TO BE USED TO REMOVE THE COWL FROM THE BASE (See fig. 2a).

**Under no circumstances must they be used to lift the complete unit. note also that units must not be stacked.**

**Fixing**

All the units are designed to be fixed onto curbs (by others) although pre-fabricated curbs manufactured in aluminium alloy are available from NuAire as optional extras. More information about the curb fixing arrangements is shown on the following pages.

**MOUNTING ANGLE**

The unit may be installed at any angle up to 40° from the horizontal but the shutters MUST run up the slope to ensure satisfactory shutter operation and weather sealing.

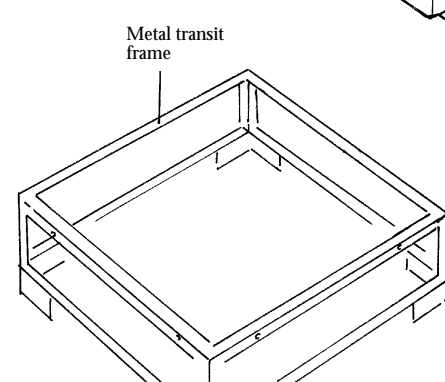
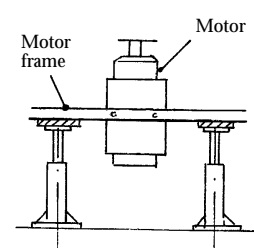
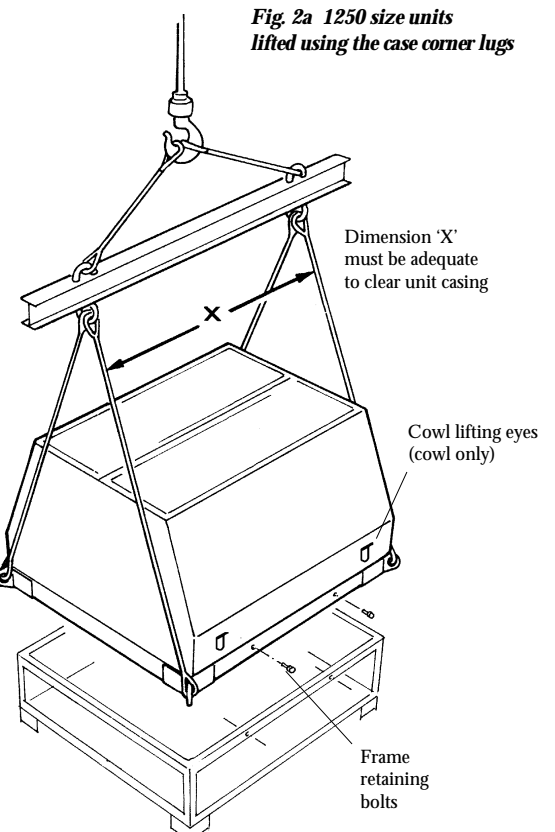

**Fig. 2b Unit with its wooden transit frame still in position.**

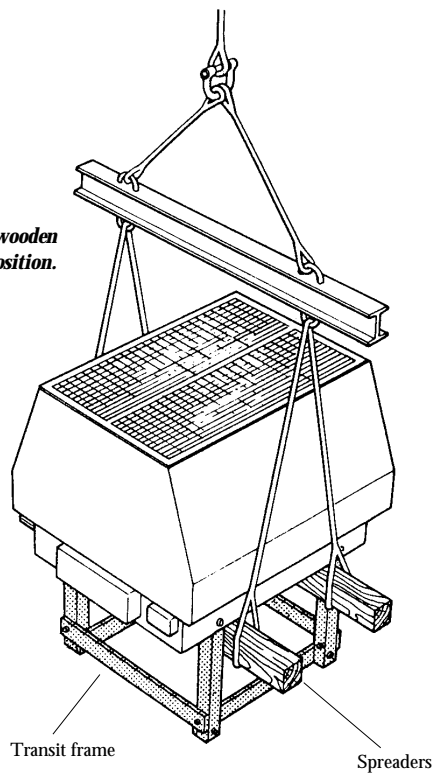

**Fig. 2c Supporting a larger size unit and releasing the transit**

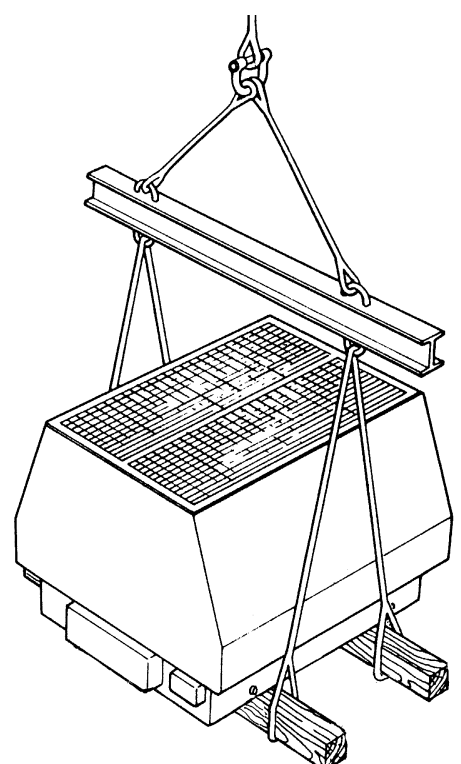

**Dimensions**

*Fig. 3 Unit dimensions and weights*

Unit Code	A	B	C	D	Unit weight kg
AXR 56	845	570	535	786	93
AXR 71	1100	770	760	1095	146
AXR 100	1295	1000	880	1234	364
AXR 125	1795	1300	1160	1738	615

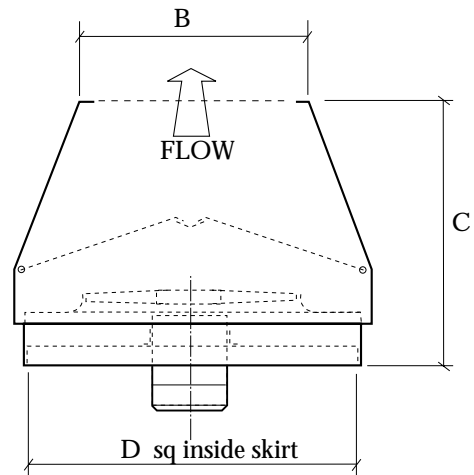
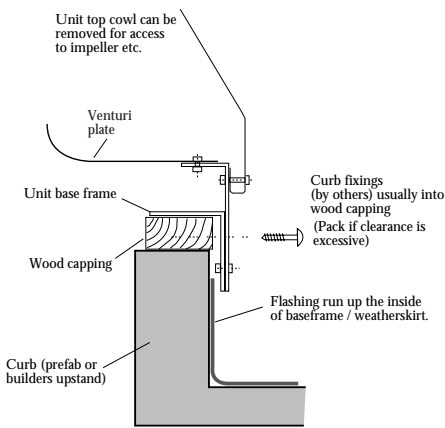
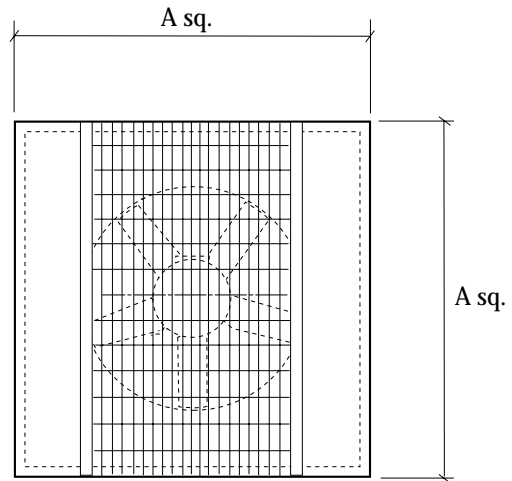

*Fig. 4 Part section through typical upstand*

**Installation (builders upstand)**

The AXR fan unit must be securely attached to the curb or mounting to prevent damage by wind or vibration. Holes are provided which allow the unit to be directly attached. Fixing bolts should be of non corrodible type).

**Note Mounting angle**

Units can be mounted on pitched roofs having an angle of not more than 40° from the horizontal. They must be installed with their shutters running up the slope to ensure satisfactory operation of the gravity operated shutters.

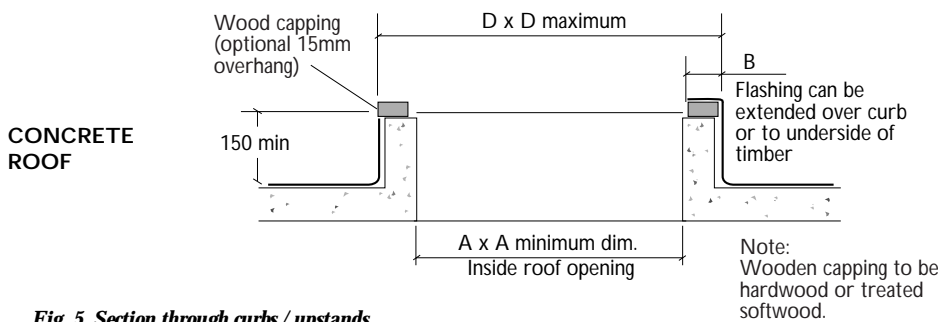

*Fig. 5 Section through curbs / upstands*

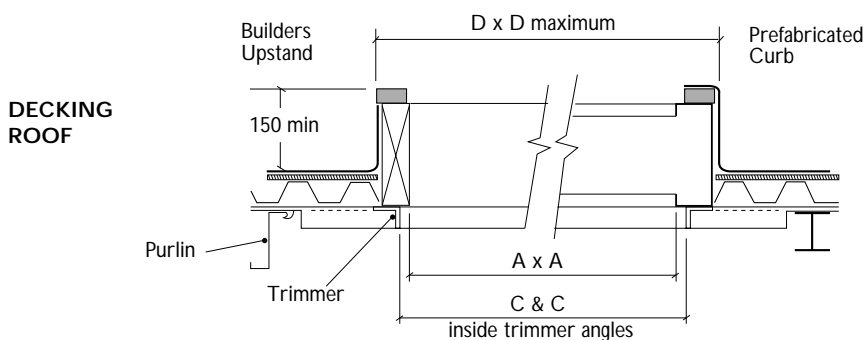

Curb Dimensions (mm)

Code	A	B	C	D
AXR56	600	75	675	746
AXR71	800	100	875	1016
AXR100	1000	100	1100	1198
AXR125	1500	100	1600	1700

**Installation using a Prefabricated Curb**

NuAire pre-fabricated curbs are manufactured in aluminium alloy with adjustable wooden cappings set to the maximum overhang position of 15mm.

The roof flashing can be run up the sides of the curb to finish just beneath the top. Alternatively if adequate clearance is available the flashing could be run over the top of the capping prior to lowering the unit onto the curb.

When installed the curb must be bolted securely to the roof trimmer angles.

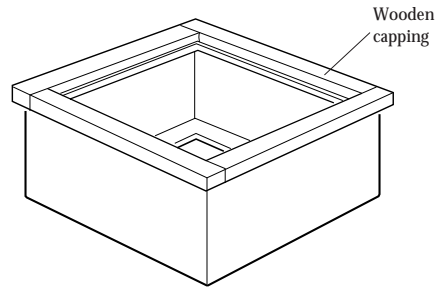

Prefabricated curb upstand (available from NuAire)

Fig. 6 NuAire prefabricated curb.

**Soaker Sheet**

Soaker sheets are manufactured in GRP and can be supplied to match most roof profiles. The soaker sheet should be placed over the prefabricated curb, trimmed to height and built into the roof in accordance with standard building practice.

**Electrical details (300°C units)**

Unit Code	Speed r.p.m.	Power kW	300°C DOL f.l.c	60 mins amps sc	300°C Star / Delta f.l.c	60 mins amps sc
AXR56-413A7	1440	0.75	1.7	11	-	-
AXR56-423A7	1440	0.75	1.7	11	-	-
AXR56-433A7	1440	1.50	3.2	21	-	-
AXR71-413A7	1440	1.10	2.6	17	-	-
AXR71-423A7	1440	2.20	5.2	32	-	-
AXR71-433A7	1440	3.00	7.0	46	-	-
AXR100-413A7	1440	5.50	11.5	78	11.5	26
AXR100-423A7	1440	7.50	16.4	120	16.4	40
AXR100-433A7	1440	11.00	23.0	171	23.0	37
AXR100-443A7	1440	15.00	30.5	219	30.5	73
AXR125-613A7	960	7.50	17.5	76	17.5	25.2
AXR125-623A7	960	11.00	23.3	108	23.3	36
AXR125-633A7	960	15.00	31.5	204	31.5	68
AXR125-643A7	960	18.50	37.2	237	37.2	79

**Electrical details (400°C units)**

Unit Code	Speed r.p.m.	Power kW	400°C DOL f.l.c	120 mins amps sc	400°C Star / Delta f.l.c	120 mins amps sc
AXR56AY-413S8	1410	0.55	1.58	6.6	-	-
AXR56AY-423S8	1420	0.75	1.88	8.3	-	-
AXR56AY-433S8	1425	1.10	2.5	13.5	-	-
AXR56AY-443S8	1425	1.10	2.5	13.5	-	-
AXR56AY-453S8	1425	1.50	3.4	19.4	-	-
AXR56AY-453S8	1425	1.50	3.9	19.4	-	-
AXR71AZ-413S8	1425	1.10	2.7	13.5	-	-
AXR71AZ-423S8	1425	1.50	3.9	19.4	-	-
AXR71AZ-433S8	1420	2.20	5.0	30	-	-
AXR71AZ-443S8	1430	3.00	6.5	43	-	-
AXR71AZ-453S8	1430	4.00	8.4	49	8.4	16.3
AXR100AZ-413S8	1430	4.00	8.4	49	8.4	16.3
AXR100AZ-423S8	1440	5.50	10.6	72	10.6	24
AXR100AZ-433S8	1440	7.50	16.0	109	16.0	36
AXR100AZ-443S8	1460	11.00	21.0	161	21.0	53
AXR100AZ-443S8	1450	15.00	28.0	216	28.0	72
AXR125BA-613S8	960	5.50	13.2	70	13.2	23
AXR125BA-623S8	970	7.50	16.0	104	16.0	34
AXR125BA-633S8	970	11.00	22.7	170	22.7	56
AXR125BA-643S8	970	15.00	31.0	200	31.0	66
AXR125BA-653S8	975	18.50	37.0	238	37.0	79

**Connection details**

Fans with motors up to 3.0kW are suitable for connection in the STAR method and also to a Direct On Line (DOL) starter. The Star connection will be made at works on all but the EEXD motors..

Fans with motors of 4.0kW and above will have all six ends of the motor windings brought out to the terminal box on all but the EEXD motors. These motors should be connected in the DELTA mesh for connection to a DOL starter.

4.0kW motors and above are also suitable for connection to a STAR / DELTA controller, but as smoke fans are required to start with the minimum of delay in an emergency, this method of control is not recommended.

Motor overload protection should be provided for continuous run-

ning and routine testing. **This protection must be defeated for emergency operation to allow the fan to run to destruction.** Supply fuses should be H.R.C. type.

**Start up procedure**

When starting ensure that the impeller rotation follows the label arrow indicator on the casing. Should the direction be incorrect on three phase units, reverse any two of the supply leads. See the wiring diagrams on page 8.

Care should be taken to set correct rotation as incorrect rotation may result in damage to the motor.

Equipment should be run for approximately 30 minutes to ensure correct operation. If any fault occurs, the equipment should be switched off. Do not re-start until the fault has been rectified.

Three phase for D.O.L. starting, Single Speed below 4kW.

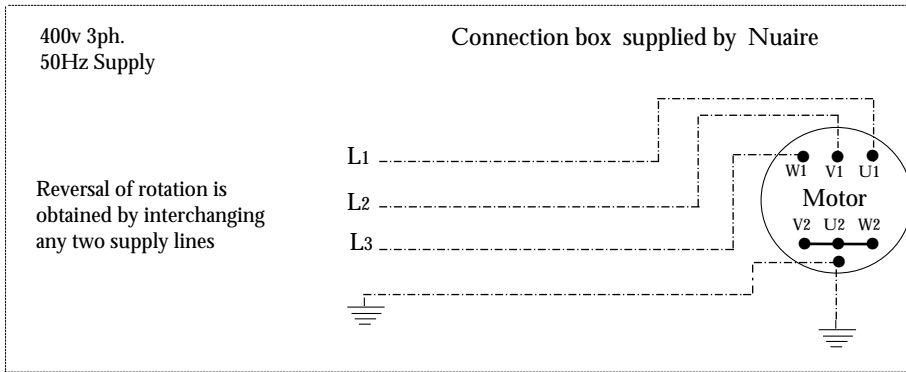

Three phase for D.O.L. starting, 4kW and above. Recommended by NuAire for safety reasons.

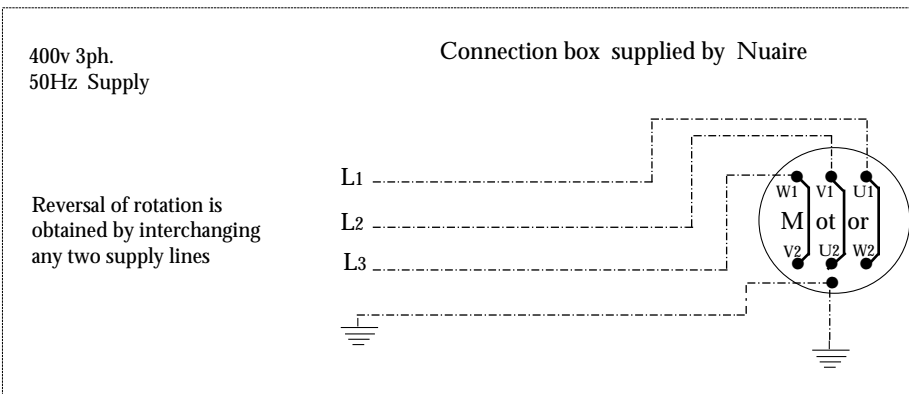

Three phase for Star / Delta starting, 4kW and above.

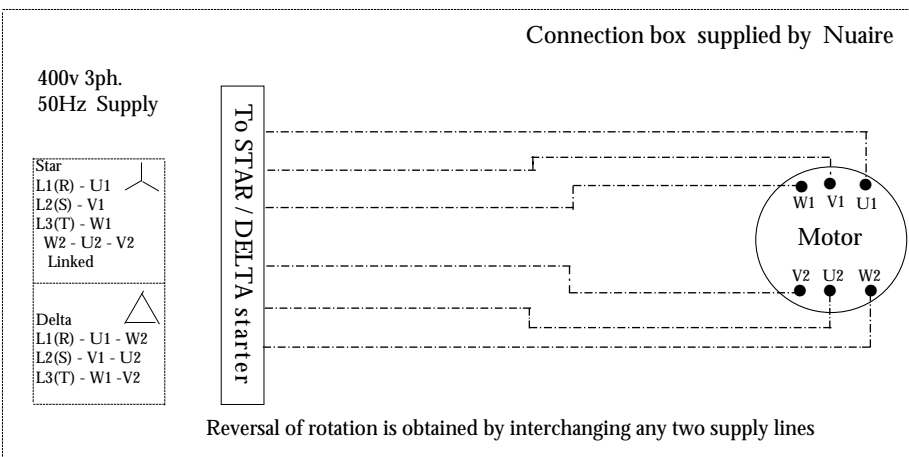

Two Speed Unit. D.O.L. starting only. For TAP / PAM wound motors.

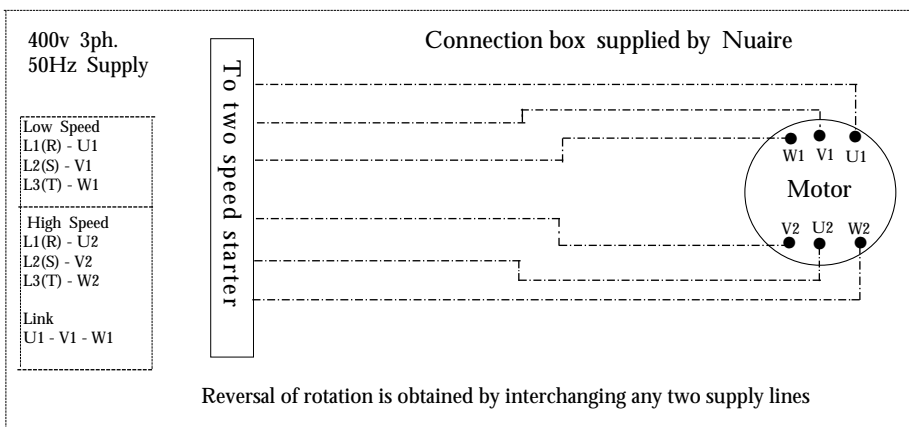

Wiring

Customer / installer wires to the terminal box located on the fan casing

Single Speed Units with motors rated below 4kW

are wired for D.O.L. starting only. For safety reasons NuAire recommends that all Smokefoil units are wired for D.O.L. starting

All two speed units must be wired for D.O.L. starting.

Note:

Star /Delta starting is available but must only be used where permitted by the appropriate approval authorities

Controls

A range of matching starters / controls are available.

Contact us to discuss your specific requirements.

Please specify D.O.L. or Star / Delta.

Testing Warning!

Before carrying out any test, check that no loose items, tools etc. are left inside the unit. The fan should not be operated with panels removed. If this proves impractical (during testing for example) ensure that all personnel are well clear of the unit.

Testing

Switch on the fanunit for a sufficiently long period to ensure that the impeller runs correctly. Switch off during the run-

down period check for correct direction of rotation and for evidence of any fault as follows:-

- a) Check that impeller is rotating freely with no signs of slipping.
- b) Check direction of rotation. A single phase unit is unlikely to be incorrect, as the unit was carefully checked at works prior to delivery. To change the direction of rotation on a three phase unit simply reverse any two of the supply connections in the isolator box.

**Controls**

**General**

Standard controls operate on electrical mains supplies of 400 volts 3 phase 50Hz and control supplies of either 230 volts 1 phase 50Hz or 24 volts d.c. Three versions are available.....

1. **Smokeclearer Control: Emergency Use only,** for Smokeclearers installed for emergency smoke clearing only.
2. **Smokeclearer Control: Day to Day with Emergency Override,** provides manual ventilation as well as emergency smoke clearing control of Smokeclearers fitted with single speed motors.
3. **Smokeclearer Control: Low speed Day to Day & High Speed Emergency** provides normal ventilation control at slow speed as well as emergency smokeclearing control at fast speed of Smokeclearers fitted with two speed motors.

Controls are designed for use with remote emergency switches and/or smoke detectors which have voltage free contacts open when operated. Each control is fitted with and EMERGENCY START push button on its front face and a mains isolator.

Dual Purpose controls (2 and 3) have, in addition, NORMAL START and NORMAL STOP push buttons for normal ventilation control and an AUTO-RESET-TEST key switch for proving the emergency exhaust function and for resetting when required. In and emergency, the fan motor can be started in one of three ways: activation of one of the automatic smoke detectors, operation of one of the remote emergency switches or by using the EMERGENCY START push button on the control panel.

**Smokeclearer Control for Emergency Use only.**

(See fig. 7)

This control incorporates a control relay (R) and a motor contactor (C) for DOL starting. In service, the relay is kept energized by the maintained control supply through the remote emergency switches (as fitted), the smoke detectors and the control panel emergency start switch.

A now open pair of relay contacts holds the contactor open. Operation of any emergency start switch (remote or on the control panel) will de-energize the relay, whose contacts close to energize the contactor, after a pick-up delay of approximately 20 milliseconds provided by the thermistor, to start the fan motor. The contactor becomes latched to ensure continuous running.

**All wiring to the controls (Dual Purpose or Emergency Exhaust Only) and from the Controls to the Smoke-clearers, must be heat and fire resisting, The electrical supply to each Control must be maintained in the event of fire and must be protected by HRC switch fuse, clearly labeled 'FIRE PROTECTION SUPPLY - DO NOT SWITCH OFF'**

Fig. 6 Standard Smokeclearer Controls.

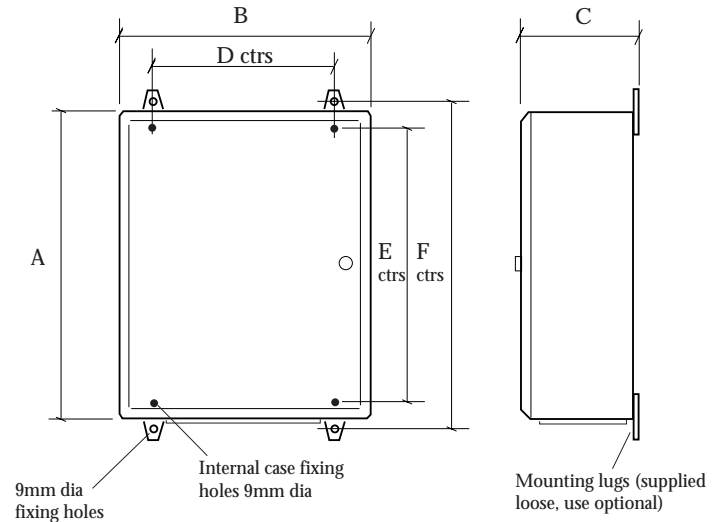

Control Function	Control Code	Dimensions (mm)						
		A	B	C	D	E	F	G
Smokeclearer Control for Emergency use only	SCEMER	300	250	150	204	254	358	40
Smokeclearer Control for Day to Day with Emergency Override	SCDD	400	300	200	254	354	458	40
Smokeclearer Control for Low Speed Day to Day, High Speed Emergency	SCDDTS	400	300	200	254	354	458	40

Separate maintained supply 415V 3ph and N 50Hz supply (Heat and Fire resistant cable)

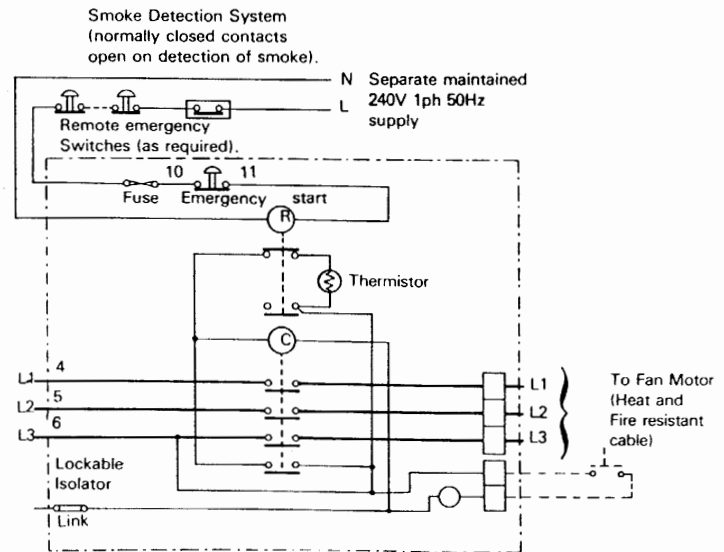

Maintained Control Supply can be 24 volts d.c. or 240 volts 1 Ph 50Hz a.c., as required

Fig. 7 Control wiring diagram, Emergency use only

**Controls (continued)**

**Smokeclearer control,  
Day to Day,  
Emergency Override (See Fig. 8)**

This control incorporates a control relay (A) a motor contactor (S) in series with a triple pole thermal overload relay, and a motor contactor (F). Both contactors provide DOL starting of the fan motor, contactor (S) for normal ventilation control and contactor (F) for emergency smokeclearing control.

In service, relay (A) is kept energized by the maintained control supply through the remote emergency switches (as fitted), the smoke detectors and the control panel emergency start switch. Relay contacts 30-31 are now open to prevent energization of contactor (F) thus inhibiting operation for the emergency exhaust circuits. Contacts 25-26 are closed in the coil circuit to contactor (S), through the NORMAL START and NORMAL STOP push buttons.

In emergency, operation of any emergency start switch (remote or on the control panel) or a smoke detector will de-energize relay A. contacts 25-26 will open to break the circuit to contactor (S), thus inhibiting normal ventilation control. Contacts 30-31 will close to energize contactor (F), after a pick-up delay of approximately 20 milliseconds provided by the thermistor, to start the fan motor. The contactor becomes latched to ensure continuous running. In the emergency mode, the thermal overload relay is out of circuit.

The AUTO-RESET-TEST switch is shown in the AUTO position, when it forms part of the latching circuit to contactor (F). In the TEST position the switch provides a means of proving the emergency circuits during normal service. Switching to RESET, in either the AUTO or TEST positions, breaks the contactors latching circuit to return the control to normal. The key which operates the switch can be removed in the AUTO and the TEST positions, but not in the RESET position.

**Smokeclearer Control,  
Low Speed Day to Day,  
High Speed Emergency (Fig. 9)**

This control is similar to the Day to Day, Emergency Override one featured above. For normal ventilation, contactor (S) operates in the same way to control the two speed motor fitted, but only at slow speed through output terminals 1,3,5. For emergency purposes, contactors (F) also operates in the same way to run the motor, but at fast speed through terminals 7,9,11. An additional relay (F1), in parallel with contactor (F), provides the star point by connecting together output terminals 1,3,5.

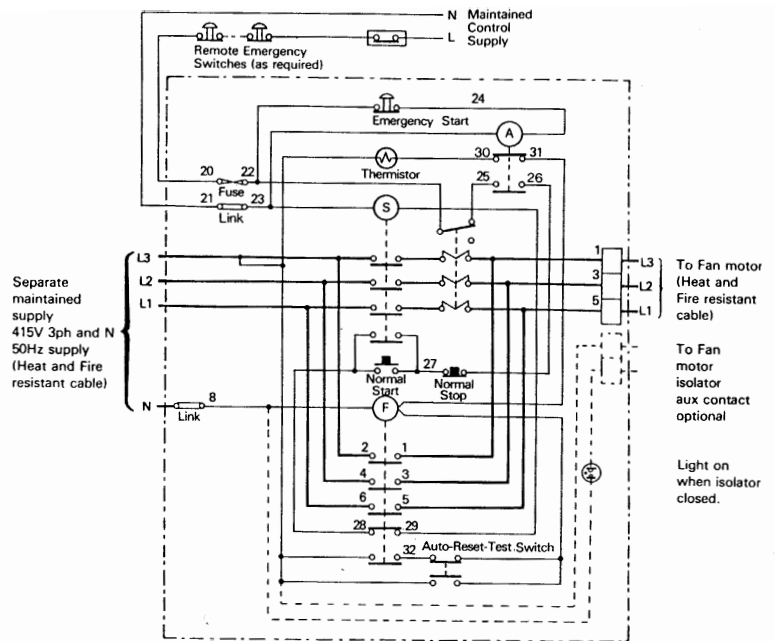

**Fig. 8 Control wiring diagram. Day to Day, Emergency Override.**

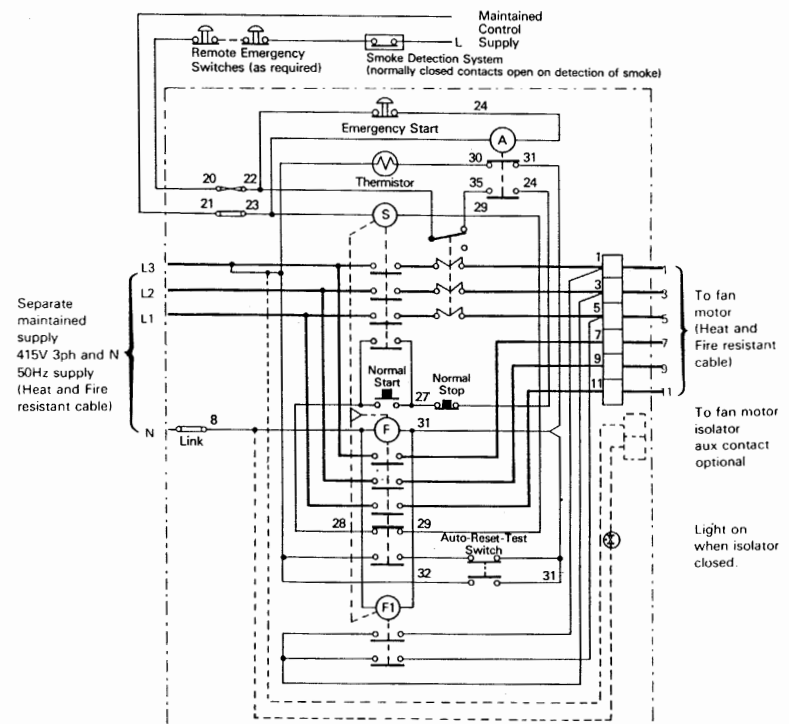

**Fig. 9 Control wiring diagram 'Low Speed, Day to Day, High Speed Emergency'.**

Maintained Control Supply can be  
24 volts d.c. or 230 volts 1 Ph 50Hz  
as required

## Maintenance

### ISOLATION

**BEFORE COMMENCING WORK MAKE SURE THAT THE UNIT AND NUAIRE CONTROL, IF FITTED, ARE ELECTRICALLY ISOLATED FROM THE MAINS SUPPLY.**

**Electrically isolate unit before removing any panels. Make sure that the unit and any speed control (if fitted) are externally electrically isolated from the supply.**

It is essential that maintenance work on Smokecontrol fans is carried out regularly.

### Intervals

First inspection three months after the unit has been commissioned. Thereafter at six monthly intervals. These intervals may need to be shortened if the unit is operating in adverse environmental conditions, or in heavily polluted air.

### Lubrication

Motors are fitted with sealed for life bearings and therefore require no further lubrication.

### General Cleaning and Inspection

Clean and inspect the exterior of the fan unit and associated controls etc.

Remove the access panel (or top cowl on the 300 / 500 units) from the fan unit. Note that on larger unit cowls, lifting eyes are fitted to assist removal of the cowl. Inspect and, if necessary, clean the fan and motor assemblies and the interior of the case. If the unit is heavily soiled it may be more convenient to remove the fan / motor assemblies.

Check that the shutters are free to move smoothly and that they seal the appropriate fan outlet effectively.

Clean and inspect each fan and motor assembly as follows; taking care not to damage, distort or disturb the balance of the impeller.

### Checklist

- a) Check that the birdguard/ safety grille is free of any obstruction.
- b) On the 300/500 model, check that both shutters move freely through their full range of movement.
- c) Check that the impeller is clean and does not foul the casing.
- d) Visually check wiring for signs of damage, check also for loose bolts, fasteners etc.
- e) Lightly brush away dirt and dust, paying particular attention to any build up at the motor ventilating slots. If necessary, carefully remove with a blade or scraper.
- f) Stubborn dirt at the impeller may be carefully removed with a stiff nylon brush.
- g) Check all parts for security and general condition and check that the impeller rotates freely.

#### Note:

Take care not to damage or distort the impeller blades nor to disturb any balance weights attached to the impeller.

Refit the assemblies to the unit then replace the access covers or unit cowl.

If NuAire controls and or remote indicators are fitted, remove the covers and carefully clean out the interiors as necessary. Check for damage.

Check security of components. Refit the access covers.

## CE DECLARATION OF CONFORMITY

AUGUST 2000



*We declare that the machine named below  
conforms to the requirements of EC Council Directives  
relating to Electromagnetic Compatibility and  
Safety of Electrical Equipment.*

---

<b>Designation of machinery :-</b>	HIGH TEMPERATURE ROOF AXIAL FAN
<b>Machinery Types :-</b>	AXR
<b>Relevant EC Council Directives :-</b>	89/336/EEC, 92/31/EEC (EMC) 73/23/EEC, 93/68/EEC (Low Voltage Directive)
<b>Applied Harmonised Standards :-</b>	EN50081-1, EN50082-1, EN60204-1 EN60335-2-80
<b>Basis of Self Attestation :-</b>	Quality Assurance to BS EN ISO 9001 BSI Registered Firm Certificate No. FM 149

---

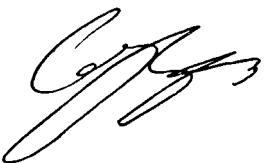
### Signature of manufacture representatives :-

	<b>Name:</b>	<b>Position:</b>	<b>Date:</b>
1)	 C. Biggs	Technical Director	2. 8. 00
2)	 W. Glover	Manufacturing Director	2. 8. 00

## **DECLARATION OF INCORPORATION & INFORMATION FOR SAFE INSTALLATION, OPERATION & MAINTENANCE**

AUGUST 2000

*We declare that the machinery named below is intended  
to be assembled with other components to constitute a system of machinery.*



*The machinery shall not be put into service until the system has  
been declared to be in conformity with the provisions of the  
EC Council Machinery Directive.*

---

<b>Designation of machinery :-</b>	HIGH TEMPERATURE ROOF AXIAL FAN
<b>Machinery Types :-</b>	AXR
<b>Relevant EC Council Directives :-</b>	98/37/EC (Machinery Directive) 93/44/EEC (Amendment to the Machinery Directive)
<b>Applied Harmonised Standards :-</b>	EN292-1, EN292-2, EN294, EN29001
<b>Applied National Standards :-</b>	BS848 Parts One, Two and Five

---

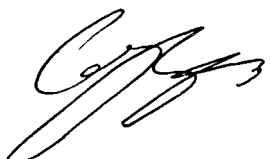
### **Signature of manufacture representatives :-**

	<b>Name:</b>	<b>Position:</b>	<b>Date:</b>
1)	 C. Biggs	Technical Director	3.8.00
2)	 W. Glover	Manufacturing Director	3.8.00

# **INFORMATION FOR SAFE INSTALLATION, OPERATION AND MAINTENANCE OF NUAIRE VENTILATION EQUIPMENT**

**To comply with EC Council Directives 89/392/EEC Machinery Directive & 93/44/EEC Amendment to the Machinery Directive.**

*To be read in conjunction with the relevant Product Documentation (see 2.1)*

## **1.0 GENERAL**

- 1.1 The equipment referred to in this **Declaration of Incorporation** is supplied by NuAire to be assembled into a ventilation system which may or may not include additional components.  
The entire system must be considered for safety purposes and it is the responsibility of the installer to ensure that all of the equipment is installed in compliance with the manufacturers recommendations and with due regard to current legislation and codes of practice.

## **2.0 INFORMATION SUPPLIED WITH THE EQUIPMENT**

- 2.1 Each item of equipment is supplied with a set of documentation which provides the information required for the safe installation and maintenance of the equipment. This may be in the form of a Data sheet and/or Installation and Maintenance instruction.  
2.2 Each unit has a rating plate attached to its outer casing. The rating plate provides essential data relating to the equipment such as serial number, unit code and electrical data. Any further data that may be required will be found in the documentation. If any item is unclear or more information is required, please contact NuAire.  
2.3 Where warning labels or notices are attached to the unit the instructions given must be adhered to.

## **3.0 TRANSPORTATION, HANDLING AND STORAGE**

- 3.1 Care must be taken at all times to prevent damage to the equipment. Note in particular that shock to the unit may result in the balance of the impeller being affected.  
3.2 When handling the equipment, care should be taken with corners and edges and that the weight distribution within the unit is considered. Lifting gear such as slings or ropes must be arranged so as not to bear on the casing.  
3.3 Equipment stored on site prior to installation should be protected from the weather and steps taken to prevent ingress of contaminants.

## **4.0 OPERATIONAL LIMITS**

- 4.1 It is important that the specified operational limits for the equipment are adhered to *e.g. operational air temperature, air borne contaminants and unit orientation.*  
4.2 Where installation accessories are supplied with the specified equipment eg. wall mounting brackets. They are to be used to support the equipment only. Other system components must have separate provision for support.  
4.3 Flanges and connection spigots are provided for the purpose of joining to ductwork systems. They must not be used to support the ductwork.

## **5.0 INSTALLATION REQUIREMENTS**

- In addition to the particular requirements given for the individual product, the following general requirements should be noted.*  
5.1 Where access to any part of equipment which **moves**, or can become **electrically live** are not prevented by the equipment panels or by fixed installation detail (eg ducting), then guarding to the appropriate standard must be fitted.  
5.2 The electrical installation of the equipment must comply with the requirements of the relevant local electrical safety regulations.

## **6.0 COMMISSIONING REQUIREMENTS**

- 6.1 General pre-commissioning checks relevant to safe operation consist of the following -  
Ensure that no foreign bodies are present within the fan or casing  
Check electrical safety. *e.g. Insulation and earthing.*  
Check guarding of system.  
Check operation of Isolators/Controls.  
Check fastenings for security.  
6.2 Other commissioning requirements are given in the relevant product documentation.

## **7.0 OPERATIONAL REQUIREMENTS**

- 7.1 Equipment access panels must be in place at all times during operation of the unit, and must be secured with the original fastenings.  
7.2 If failure of the equipment occurs or is suspected then it should be taken out of service until a competent person can effect repair or examination. (Note that certain ranges of equipment are designed to detect and compensate for fan failure).

## **8.0 MAINTENANCE REQUIREMENTS**

- 8.1 Specific maintenance requirements are given in the relevant product documentation.  
8.2 It is important that the correct tools are used for the various tasks required.  
8.3 If the access panels are to be removed for any reason the electrical supply to the unit must be isolated.  
8.4 A minimum period of two minutes should be allowed after electrical disconnection before access panels are removed. This will allow the impeller to come to rest.  
NB: *Care should still be taken however since airflow generated at some other point in the system can cause the impeller to "windmill" even when power is not present.*  
8.5 Care should be taken when removing and storing access panels in windy conditions.

## Spares

When ordering spares please quote the unit code and serial number of the unit, together with a full description of the part required. The unit's serial number and code number will be found on the identification plate fixed to the unit.

## Service

As a manufacturer NuAire can provide you with factory trained Service Engineers.

Our Engineers are supported by a comprehensive range of spare parts 'off the shelf'.

If you are an industrial or commercial user, you may be interested in details of NuAire's regular maintenance Service Contracts. This is a worthwhile service that helps you get the most from our products.

Our Service Department will be happy to give you more information.

Please telephone: **029 2085 8271**

## Controls Application Service (CAS)

A team of Engineers and technicians is available to provide pre and post order support.

We are on hand to provide help and advice from the most basic use of any NuAire equipment to the more complex applications, maximising on the versatility of our SMART and NetLink control products.

Telephone: **029 2085 8585**

Facsimile: **029 2085 8586**

## 3 YEAR WARRANTY

The three year warranty starts from the date of delivery and includes parts and labour for the first year.

The labour element is subject to full, free and safe access to the equipment as recommended by the CDM regulations.

The remaining two years covers replacement parts only.

### NOTE:

**Installation & Maintenance of the equipment must be as directed in the instructions provided with the unit.**

*Technical or commercial considerations may, from time to time, make it necessary to alter the design, performance and dimensions of equipment and the right is reserved to make such changes without prior notice.*

# NUAIRE

Western Industrial Estate, Caerphilly,  
Mid Glam CF8 1XH United Kingdom.  
Telephone: 029 2088 5911  
Facsimile: 029 2088 7033,

Leaflet No. 671063

### NOTE

If you have any comments or queries on any of our products or services please write to the Product Information Manager at the main address above