



Ecosmart Boxer Air Handling Units

A derivative of the Ecosmart Control to enable the BMS to modulate speed and temperature.

Addendum to I&M 671188



1.0 Introduction

Standard Ecosmart Air Handling Units provide an overall facility for 0 - 10V BMS signal to conjointly vary fan speed and temperature through the fully integrated control.

Where the BMS is required to exclusively vary fan speed, heating and cooling coils independent of the Ecosmart Control, the standard unit will require modification at time of manufacture.

Where this feature exists standard fan codes will carry the suffix BMS i.e the standard unit ESBS2-L, with LPHW coil and integrated Ecosmart Control becomes ESBS2-LBMS with modified control and independent connection to heating and/or cooling coil.

It is not possible to give similar control over units with electric heating coils.

2.0 Construction, handling and installation

Construction is as the standard Ecosmart Boxer Air Handling Units, the handling, mechanical and electrical installation advice given within the parent I&M document 671188 should therefore be followed.

3.0 Controls

Fan Speed Control

To vary the fan speed connect the BMS 0 - 10V signal direct to the appropriate terminals on the es board.

BMS Input Signals

The BMS connection is made with a plug-in connector via the socket (See figure 1).

To ensure the connection is made only by suitably qualified and authorised personnel the plug is not supplied with the control. It is available from:

**R S Components, Part No. 403-875 or
Farnell, Part No. 963-021.**

Figure 1.

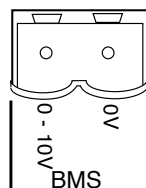

IMPORTANT

Reversal of the BMS connection will damage the control.

The system's response to a 0 - 10V dc BMS signal is given in the table below.

Note the BMS signal will override any sensors and user control connected in the system.

The voltage tolerance is +/- 125mV and is measured at the fan terminals.

Ventilation Mode

Local control	0.00
OFF / trickle	0.25
Speed 1	1
Speed 2	2
Speed 3	3
Speed 4	4
Speed 5	5
Speed 6	6
Speed 7	7
Speed 8	8
Speed 9	9
Speed 10	10

Coil Actuators

The LPHW heating coil, and chilled water cooling coil, are fitted with a three port valve and balancing valve, the actuator head is to be connected directly to the BMS. The BMS has to provide a 24V power supply in addition to the 0 - 10V modulating signal. The BMS must also provide frost detection and adjust the valves accordingly.

Figure 2. Actuator head, type Honeywell model M7410E1028

Figure 3. Actuator head, type Belimo model SM24-SR

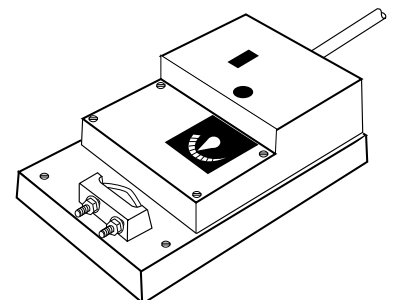
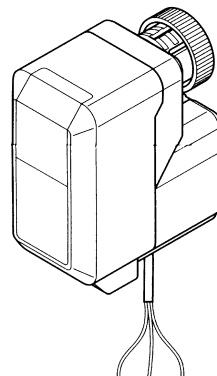

continued on page 2.

4.0 Electrical connections for unit sizes 1 and 2

Speed Control

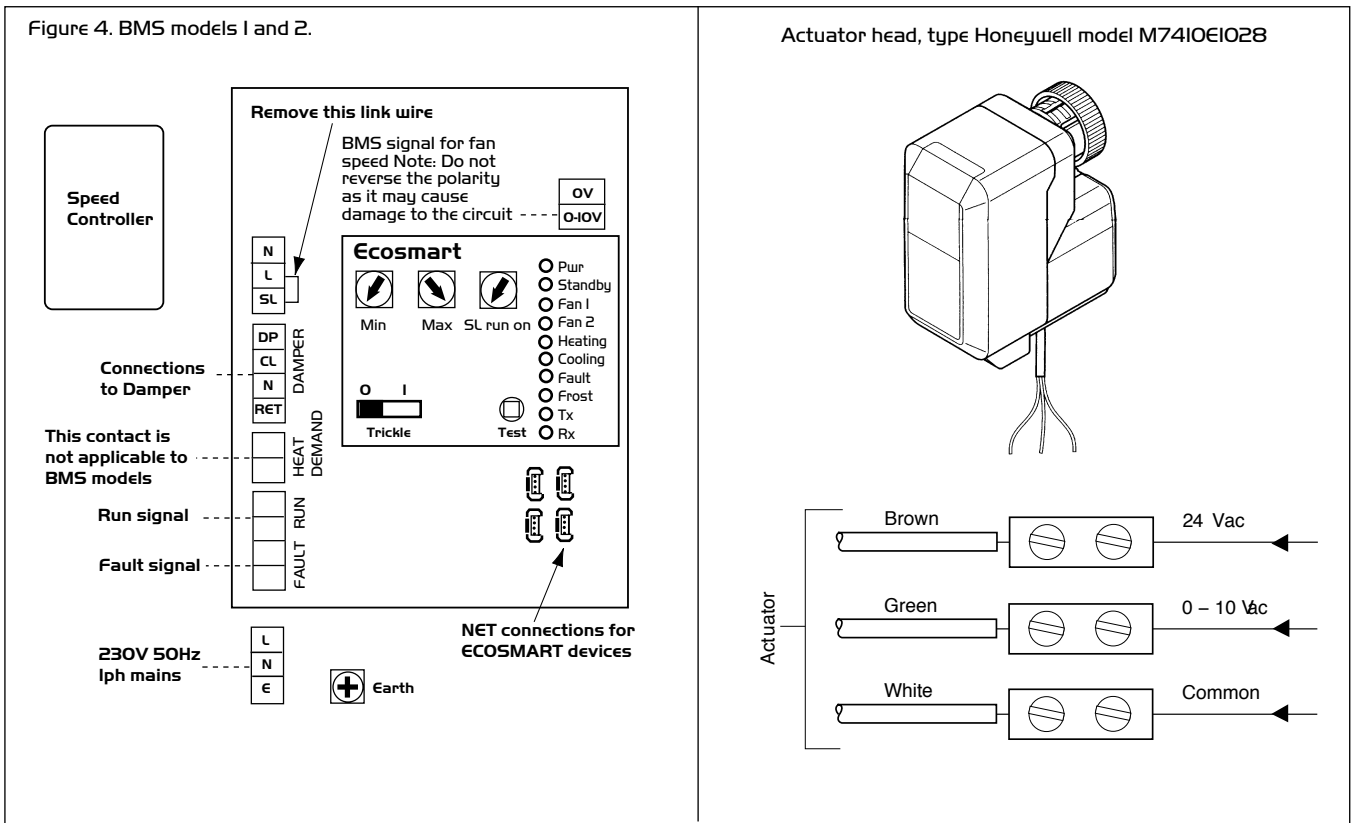

4.1 Electrical connections for unit sizes 3 to 7

Speed Control

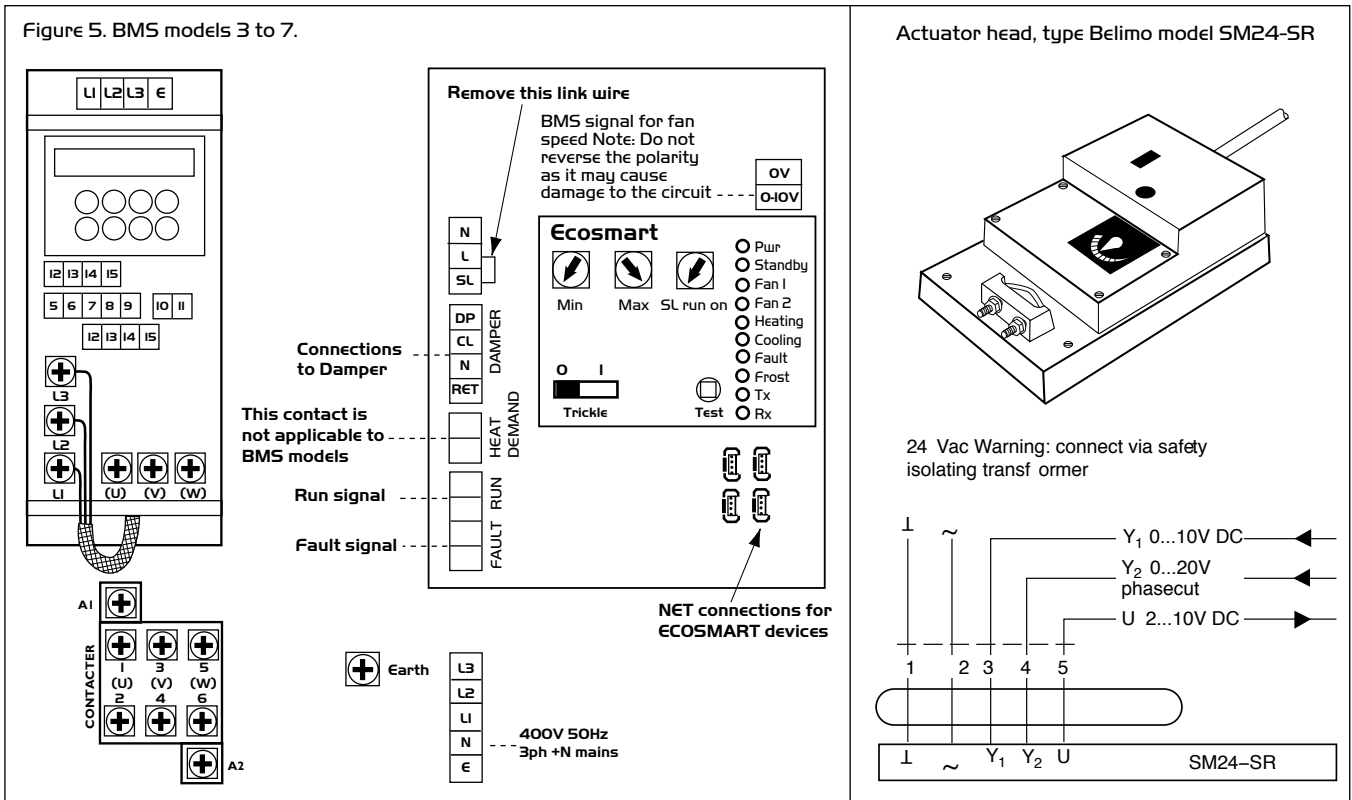

Technical or commercial considerations may, from time to time, make it necessary to alter the design, performance and dimensions of equipment and the right is reserved to make such changes without prior notice.