



# Ecosmart Boxer Air Handling Units

Erection/Assembly Units Sizes 3 to 7

Figure 1.

## Securing sections face to face

The units frame will require bolting together using matched drilled flanges and the nuts and bolts provided. In addition fishplates must be used to join two base frames together.

## Securing sections side by side

i.e. units and heat exchangers, the inside rail of one base frame is to be removed and cross brace coupling brackets used to secure the installation. (See figure 2).

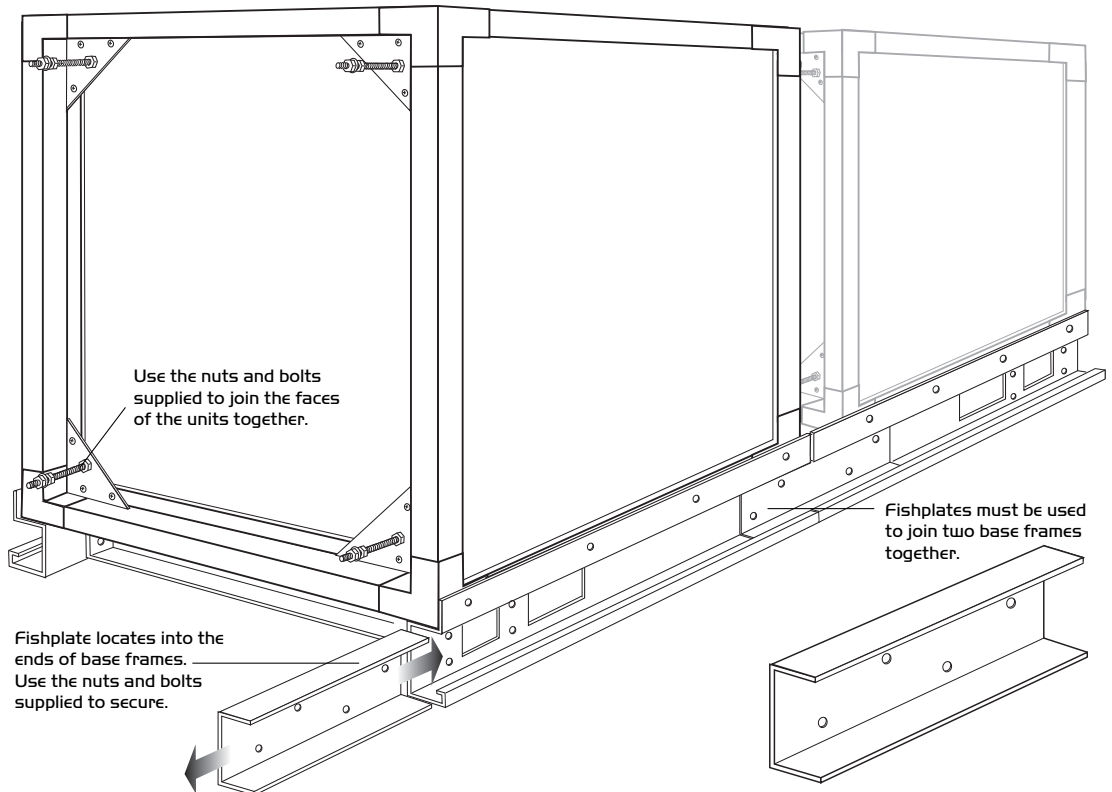
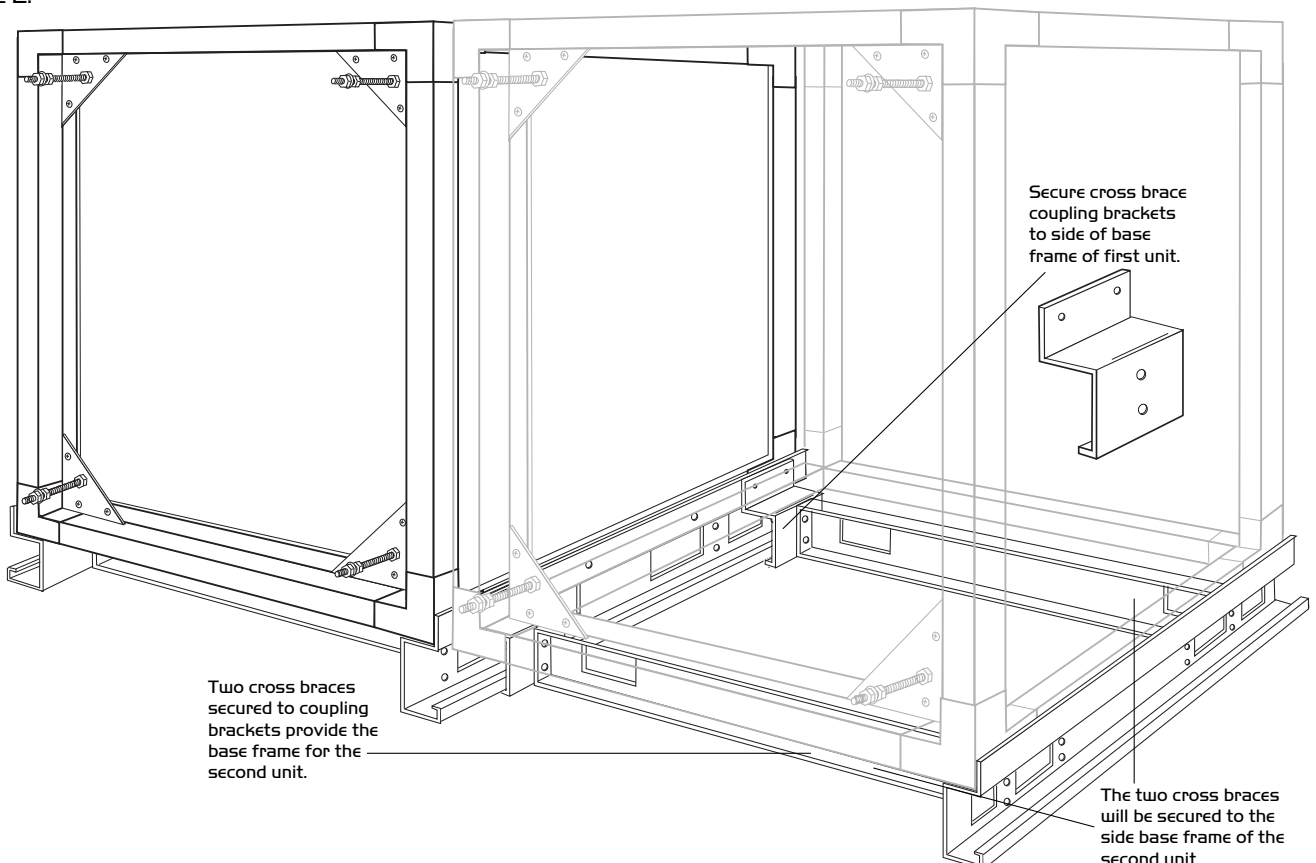

Figure 2.



Wiring

Figure 3. ESBS3-E, ESBS4-E, ESBS5-E, ESBS6-E and ESBS7-E

**IMPORTANT**  
Section A is an adjacent module in which additional controls and sensors are installed. Ensure these devices are connected to the Ecosmart control by terminating at points B & C.

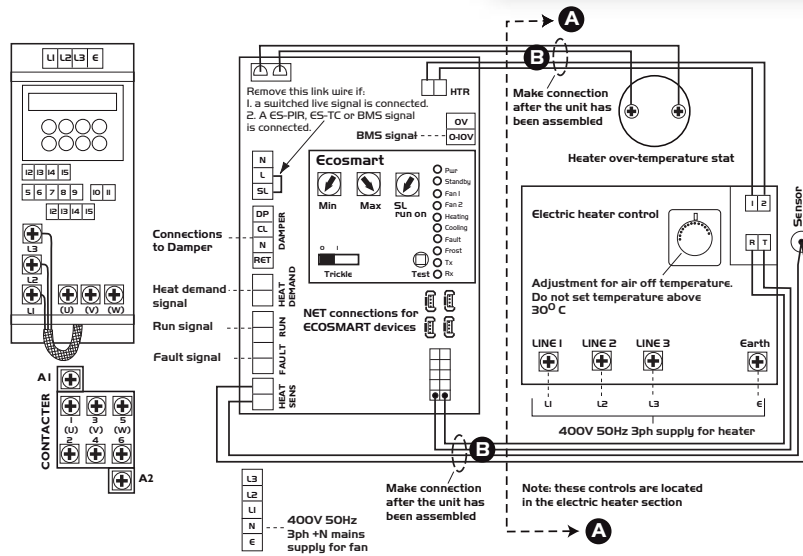
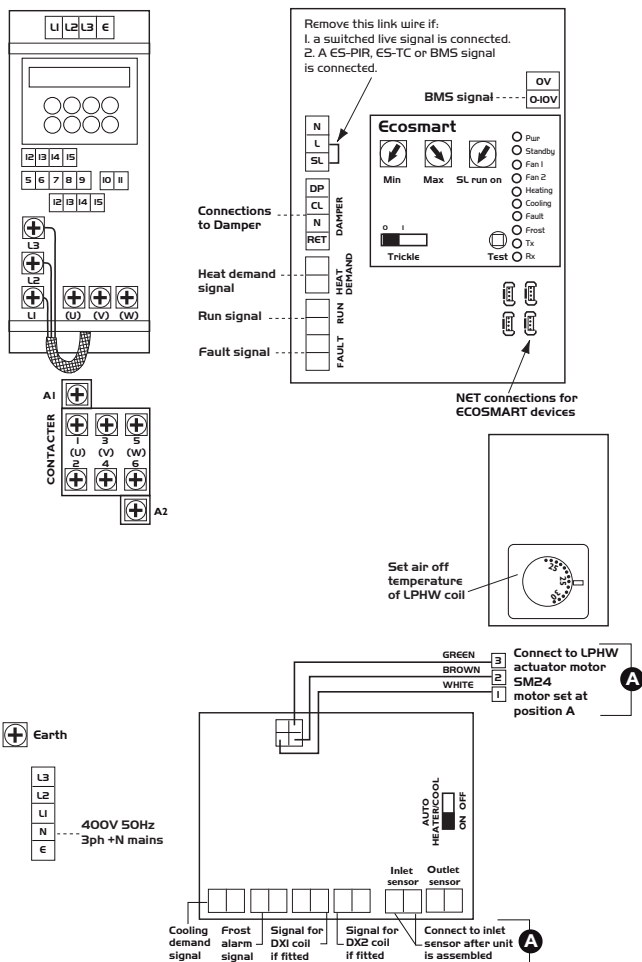
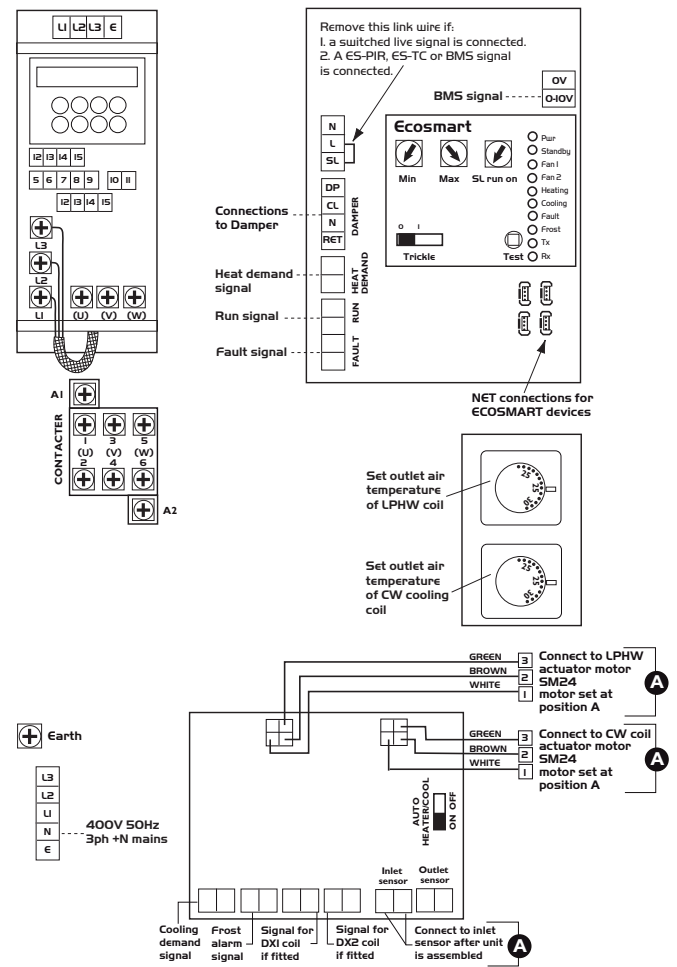

Figure 4. ESBS3-L, ESBS4-L, ESBS5-L, ESBS6-L and ESBS7-L  
ESBS3-LD, ESBS4-LD, ESBS5-LD, ESBS6-LD and ESBS7-LD



**IMPORTANT**  
Actuator and sensors (A) are positioned in adjacent modular sections and will require wiring and connection to the Ecosmart control.

Figure 5. ESBS3-LC, ESBS4-LC, ESBS5-LC, ESBS6-LC and ESBS7-LC



**IMPORTANT**  
Actuator and sensors (A) are positioned in adjacent modular sections and will require wiring and connection to the Ecosmart control.