

CVD125/150/200

Constant Volume Dampers

CE The EMC Directive 2004/108/EC
The Low Voltage directive 2006/95/EC



Installation and Maintenance

1.0 Introduction

This constant volume damper is designed for installation with Nuaire's range of fans.

Units are rectangular in section, manufactured from galvanised steel.

The CVD damper will control the flowrate passing through it when the pressure drop across the damper is within the range stated in the performance envelope.

Two flow settings are available; trickle and boost. The damper will operate in the trickle setting when it is powered up and will go into the boost setting when a mains signal is received at the SL terminal or when the CVD-PIR (optional ancillary) is activated. A run-on timer (adjustable between 1 to 60 minutes) will hold the damper in the boost setting for the preset time period.

2.0 Dimensions Figure 1.

Plan view

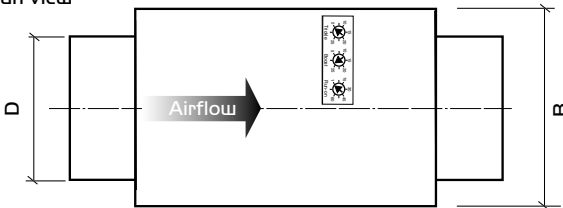

Side view

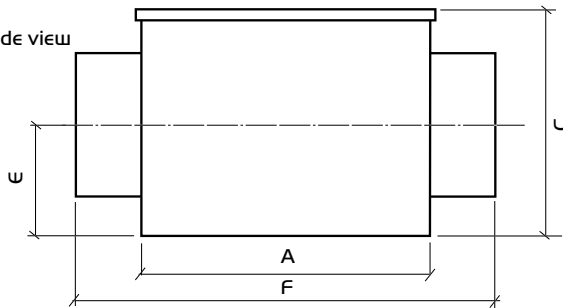

Dimensions in mm.

| Code | A | B | C | D | E | F | kg |
|--------|-----|-----|-----|-----|-----|-----|-----|
| CVD125 | 300 | 180 | 195 | 125 | 75 | 400 | 3.5 |
| CVD150 | 300 | 200 | 220 | 150 | 90 | 400 | 3.7 |
| CVD200 | 300 | 230 | 275 | 200 | 115 | 400 | 4 |

3.0 Handling

Handle the units carefully to avoid damage and distortion to moving parts.

4.0 System Design

A nominal pressure drop must be allowed in order to ensure adequate airflow through the damper. To ensure the airflow pattern through the damper produces consistent readings; the pressure drop across the damper should not exceed the recommended value. Recommended values are listed in the table following and show the performance envelope of each damper.

Nominal design pressure is the value needed to produce the maximum rated airflow for the damper. If the desired flowrate is less than the maximum, a lower design value may be used by reading off the lower curve of the appropriate chart. Please allow 40Pa.

| Model code | Nominal design pressure drop | Maximum pressure across damper* |
|------------|------------------------------|---------------------------------|
| CVD125 | 70Pa | 140Pa |
| CVD150 | 80Pa | 160Pa |
| CVD200 | 90Pa** | 200Pa |

*recommended maximum operating pressure to ensure the damper would work within calibration limits.

Keep the duct velocity as low as possible to ensure the system produces the lowest energy usage, preferably below 5m/s.

**Allow 90Pa for duties below 100l/s and 150Pa for duties between 100l/s and 125l/s.

Figure 2. Performance envelope for CVD125.

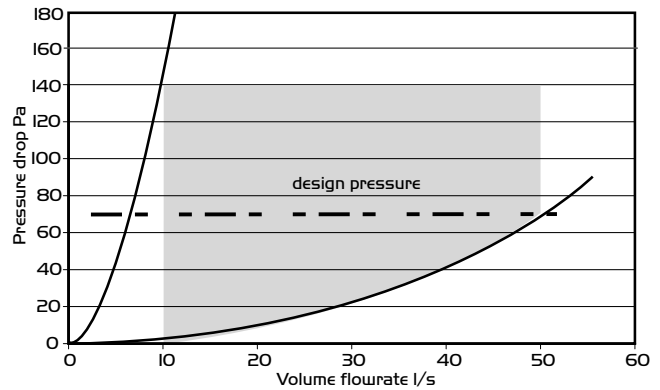

Figure 3. Performance envelope for CVD150.

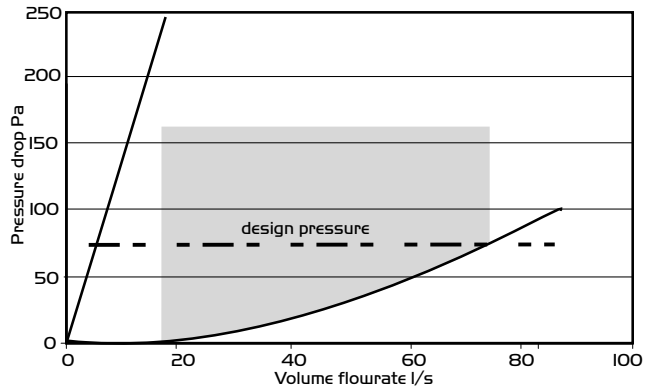
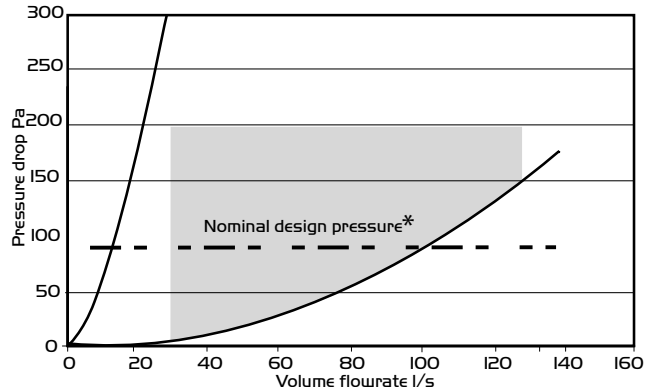

Figure 4. Performance envelope for CVD200.



*Allow 90Pa for duties below 100l/s and 150Pa for duties between 100l/s and 125l/s.

5.0 Installation

The installation must be carried out by competent personnel in accordance with the appropriate authority and conforming to all statutory and governing regulations.

IMPORTANT

The dampers must be installed indoors, away from sources of heat, steam or water spray.
 Operating ambient: 5-40°C, up to 95%RH (non condensing).
 This unit must be earthed.
 Do not distort the casing as this will cause the moving part to jam.

The CVD damper must be located in an accessible location for service and maintenance as prescribed in the CDM regulation.

If the rigid ducting at the inlet and outlet of the damper are securely fixed to their support; the damper may be coupled directly to the ducting without additional fixing. If this is not the case; secure the damper to a rigid, vibration-free surface using the brackets supplied (see fig 5).

Figure 5.

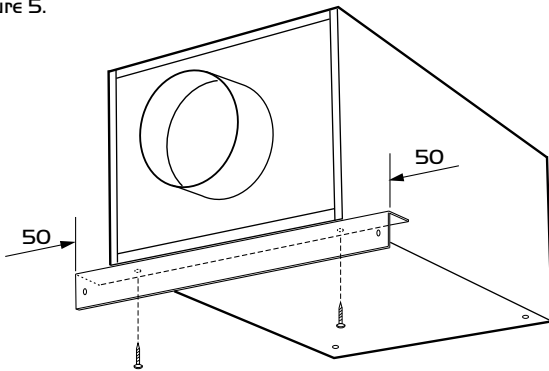

Remove the screws from the underside of the unit and use these to attach the fixing brackets.

5.1 Installation practices to obtain the best result from the CVD damper (see figure 6).

1. Always fit at least 500mm of straight RIGID ducting at the damper inlet before connecting to any bends, grilles or obstructions (see figure 6).
2. Similarly always fit at least 300mm of straight RIGID ducting at the damper outlet.
3. Do not fit balancing damper or other devices that creates a jet within 10m upstream of the inlet to the CVD damper.
4. Avoid multiple bends near the inlet side of the CVD damper.
5. Avoid the use of flexible ducting; do NOT fit flexible ducting directly on to the CVD damper. See items 1 and 2.
6. Air valves with screw-in adjustments should be set up with maximum opening.

Failure to meet these conditions means the damper's calibration may be affected and would require careful commissioning to produce the desired flowrate. See commissioning guide on page 4.

Typical accuracy of the dampers under ideal conditions are:

| Unit | Typical Accuracy |
|---------|------------------|
| CDV 125 | + or - 3 l/s |
| CDV 150 | + or - 3 l/s |
| CDV 200 | + or - 4 l/s |

IMPORTANT

Please note the dampers' orientation is indicated by the arrow. This must correspond to the direction of the airflow when installing the damper.

Figure 6. Installation practices to obtain the best result from the CVD damper.

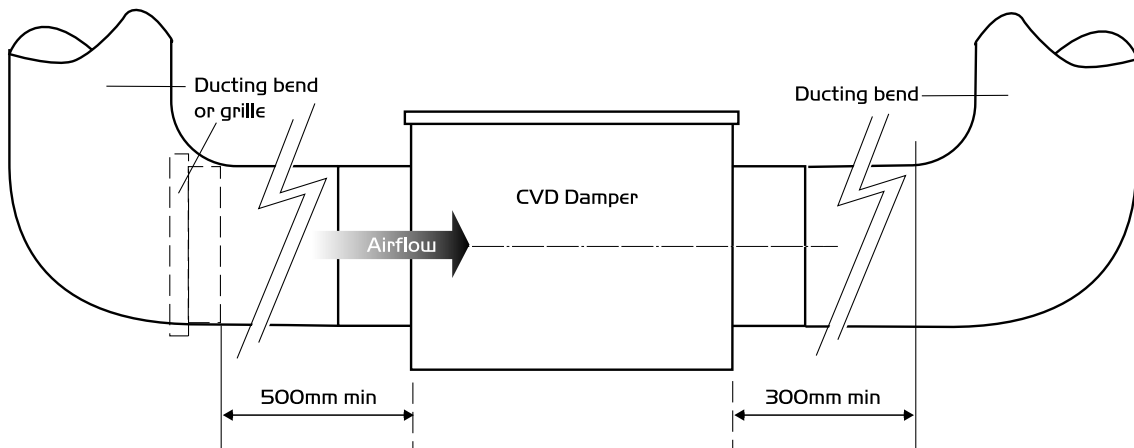

6.0 Electrical Wiring

IMPORTANT

Warning - Isolate the mains power before carrying out any electrical wiring.
The unit must be supplied via an all-pole isolator with at least 3mm gap as illustrated in the figure 7.
The recommended fuse rating is 1A.
This unit must be earthed.
A permanent mains supply must be connected for normal operation.

Remove the three screws holding the top cover to gain access to wiring terminals.

Feed the cable through the grommetted hole and wire into the terminals as shown in figure 7.

Secure the cable using the cable clamp supplied.

Electrical rating: 230V~50Hz 3W.

Figure 7. General wiring viewed with cover removed.

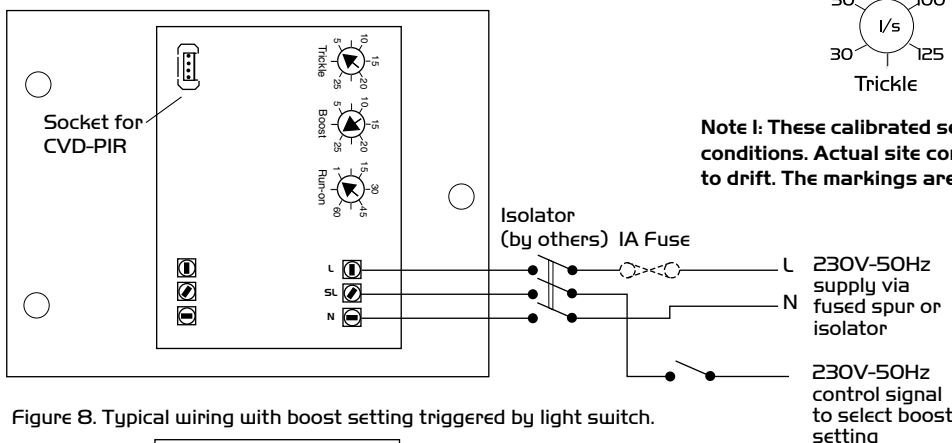
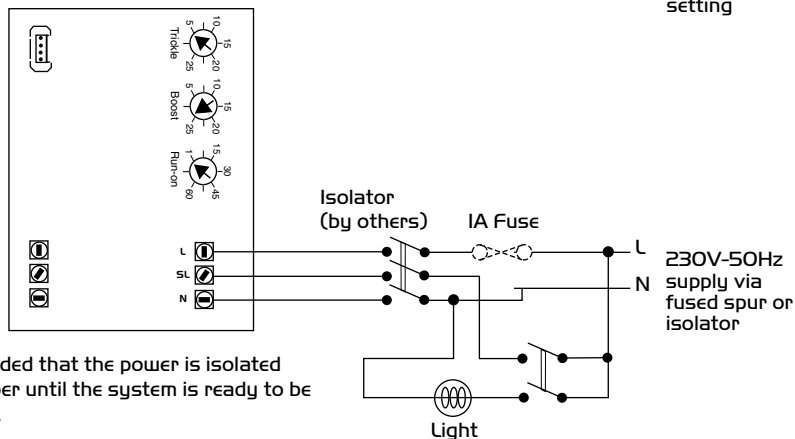

Figure 8. Typical wiring with boost setting triggered by light switch.



It is recommended that the power is isolated from the damper until the system is ready to be commissioned.

8.0 Maintenance

The damper should be inspected after the first 6 months of operation. Remove any accumulated dust and dirt using a soft brush and low power vacuum cleaner (e.g. a small battery operated model). Thereafter, inspect and clean the damper as site condition dictates. We recommend that inspection should take place at least once a year.

9.0 Warranty

The damper is supplied with a 5 year warranty. The first year includes parts and labour with the remaining period parts only. The warranty period begins on the date of delivery.

7.0 Operation

The trickle and boost flowrate together with the run-on time are adjustable via relevant potentiometers. These are accessible through the top cover without removing the lid.

Use a screwdriver to make the adjustment. Take care not to rotate the potentiometer beyond its limits of travel.

When power is connected; the damper will enter a test mode which takes approximately 2 minutes.

The damper will start operating normally after this period.

Figure 9a. Dial calibration for CVD125 (see Note 1)

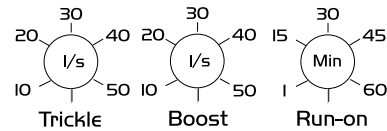

Figure 9b. Dial calibration for CVD150

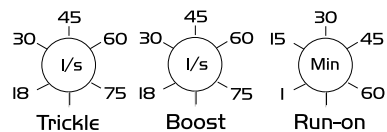
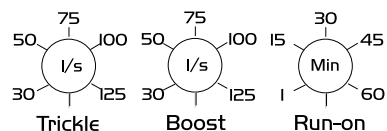

Figure 9c. Dial calibration for CVD200



Note 1: These calibrated settings were obtained under laboratory conditions. Actual site conditions may cause these calibrations to drift. The markings are therefore for guidance only.

10.0 Service Enquiries

Nuaire can assist you in all aspects of service. Our service department will be happy to provide any assistance required, initially by telephone and if necessary arrange for an engineer to call.

Tel: 029 2085 8585
Fax: 029 2085 8586

IO.O Appendix I. Detailed operating sequence of CVD damper

On power up

The active LED will flash 3 times; after this the LED will be lit continuously if the switched live signal or the CVD-PIR is active (boost mode) and flash slowly if it is inactive (trickle mode). The damper will drive close for 12 seconds then open for 15 seconds. The damper will then drive close for 90 seconds to ensure it starts its operation from the fully closed position. Some noise may be heard during this period as the damper is driven against its end stop!

Warning – the unit must be connected permanently to the mains supply during normal operation. Use the switched live (SL) or the CVD-PIR to select boost setting. If the mains switch is switched on and off in normal operation, the noise generated during this start up routine may become a nuisance.

2. The unit will start to measure the airflow after the initial power on routine. If the airflow is below the minimum calibration value (e.g. 5l/s for CVD100), it will drive open until it reaches half way through its allowable travel (approximately 15mm from the foam) and stop.
3. When there is a consistent airflow greater than the minimum calibration (e.g. 5l/s for CVD100) for more than 10 seconds, the unit will begin to operate normally. The damper will be driven open or close depending on the measured airflow and the relevant set point.
4. If the fan is stopped and the damper is less than half opened then the damper will travel to half opened position and stop. If the damper is at position beyond this, it will just stop. This is to make sure the damper is opened when the fan restart. The fan is considered to have restarted the conditions given in point 3 is met.
5. The damper has a limited travel of approximately 35mm. Therefore it is essential that the gap between the foam and damper blade is less than 35mm to obtain full controllability before the damper is switched on. A maximum gap of about 20mm is recommended and would be the normal gap when the damper is delivered. Do not manually move the damper blade beyond its operating range.

Note 1:

The CVD volume control dials were calibrated in our laboratory under ideal flow conditions to give typical accuracies as given in table below. These should be used as a guide to the setting position. Site conditions may cause the calibration to drift; e.g. bends or inlet grille being too close or multiple bends. If this occurs; the trickle and boost set point should be adjusted up or down as necessary to produce the desired flowrate.

*Typical accuracies of the dampers under ideal conditions.

| | | | |
|--------------|---------|--------------|---------|
| CVD125 | +/-3l/s | CVD150 | +/-3l/s |
|--------------|---------|--------------|---------|

| | |
|--------------|---------|
| CVD200 | +/-4l/s |
|--------------|---------|

Please see leaflet 671405 for guidance on commissioning the system and CVD dampers.

Technical or commercial considerations may, from time to time, make it necessary to alter the design, performance and dimensions of equipment and the right is reserved to make such changes without prior notice.