

LPXBOXAC-2

Mechanical Ventilation with Heat Recovery Installation and Maintenance

CE The EMC Directive 2004/108/EC
The Low Voltage directive 2006/95/EC

1.0 Introduction

The Nuair LPXBOXAC-2 unit is designed to provide mechanical supply and extract ventilation with heat recovery.

The unit is fitted with two fans with independent adjustable speed control. A plate heat-exchange constructed from aluminium is used to provide up to 66% heat recovery.

Figure 1.

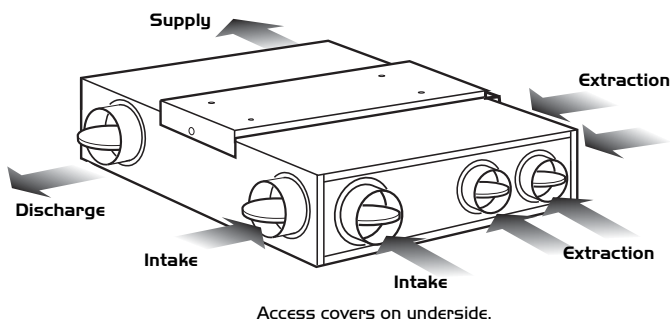

Installation of the unit

The integral mounting bracket supplied with the unit can be offered up to a chosen mounting position, the fixing points marked through and the bracket installed with 4 screws (by others).

The unit can then be offered into position, locating the tongues on the mounting bracket into the slots in the holding supports on either side of the unit. When positioned fix the unit to the mounting bracket with M5 screws.

Figure 2.

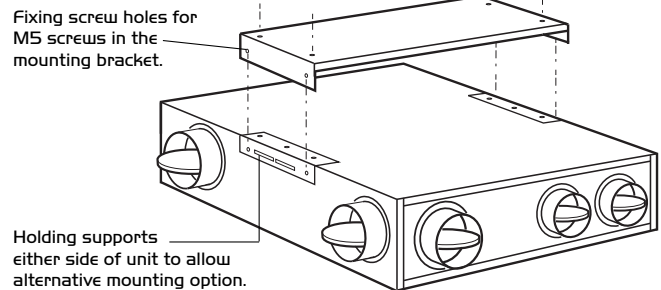

2.0 Installation

Installation must be carried out by competent personnel conforming to all statutory and governing regulations including the current wiring and CDM regulations.

Special attention must be paid to the size and weight of the unit and the handling method to locate the unit in situ.

The unit is designed to be ceiling mounted in the horizontal plane with access panel and condensate drain pipe on either side.

The fan must be fitted indoors, away from any direct sources of heat, water spray or moisture generation. Temperature range -5°C to 40°C.

Please note a clear working space is required around the installed unit to allow the cover to be removed and provide sufficient access for maintenance such as filter change.

The fan is designed to be wired direct to the mains supply through a fused spur isolator (by others).

With the unit fixed in position and working from underneath the installation bring the mains wiring through the chosen rubber cable entry grommet at the new connection box.

Additional grommeted holes are provided to allow additional wiring to each blower.

Figure 3.

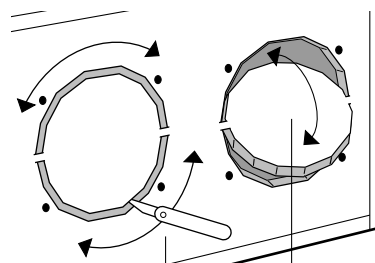

Cut through the acoustic foam round the circumference of the damper.

Figure 4.

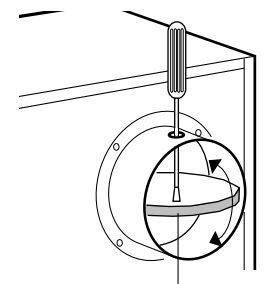

Damper can be swivelled on the 2 body casing hinges.

When spigot is in position, damper can be adjusted using a screwdriver.

Various damper/inlet spigot positions can be utilised as required to suit the system ductwork and extract grilles. To reduce air leakage, spigots should be sealed to the unit by silicone sealant or similar (by others).

All inlet dampers are 'closed' as knockouts when delivered but can be opened using a sharp knife. (See figure 3). After the spigot has been fixed adjust the damper with a screwdriver. (See figure 4).

See figure 5 for spigot location and sizes.

The condensate drain must be connected via a trap into either a suitable waste water system or to the outside of the building. Ensure the pipe from the condensate drain falls away from the unit.

2.0 Dimensions

Figure 5. Dimensions in mm.

Side view (view from B)

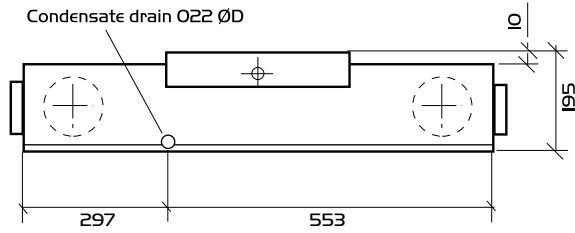

End view (view from A)

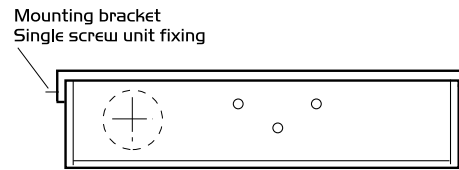

Plan view (view from top with covers removed)

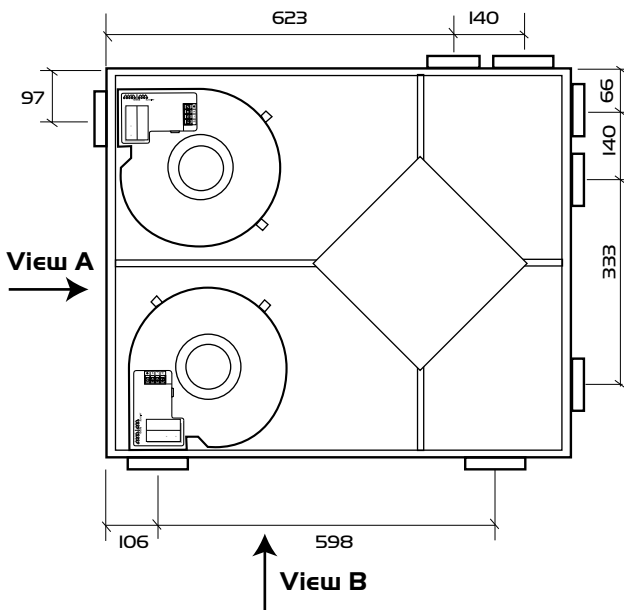

Plan view (view from underside with covers removed)

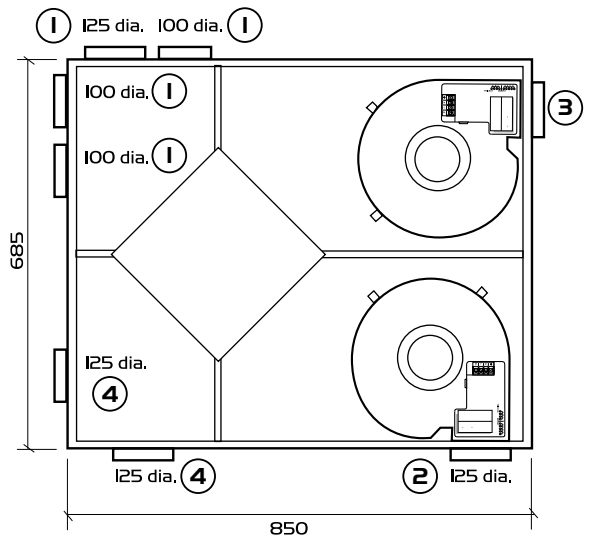

General view of unit

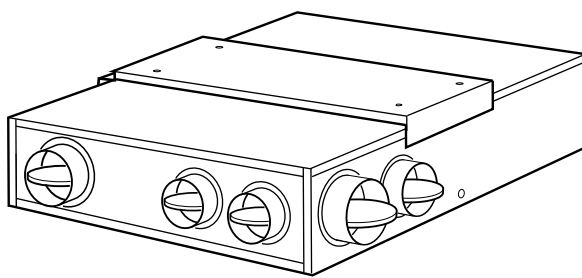

Plan view (Mounting bracket)

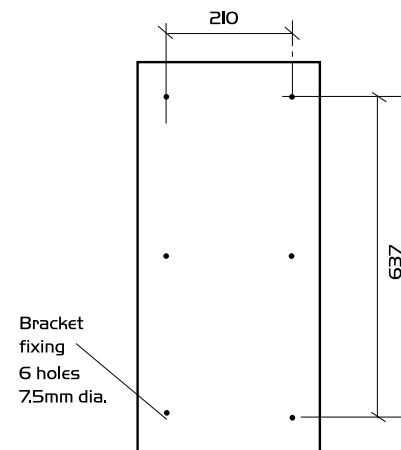

IMPORTANT

Any air intake terminal **MUST** be installed in accordance with the appropriate regulation.

As a guide, the BS5440 series of British Standards deals with this issue and currently states that an air intake must be at a minimum distance of 300mm from a gas boiler balanced flue. Installers are advised to be aware of the requirements of this standard when installing 'through the wall' supply air ducting.

Similarly, supply and extract air grilles should be at least 300mm apart.

Key

- ① **Extract** - stale air ducted from within 'Wet' rooms in the building.
- ② **Discharge** - is the extracted air from the building ducted to the outside and removed.
- ③ **Supply** - is the fresh air ducted into the building. This may be sent to more than one room.
- ④ **Intake** - is the fresh air source ducted from outside.

3.0 Electrical Wiring

IMPORTANT

Isolation - Before commencing work make sure that the unit, switched live and Nuaire control are electrically isolated from the mains supply. Please note this product must be earthed.

IMPORTANT

Unit must not be switched off, product is designed to run continuously.

Figure 6.

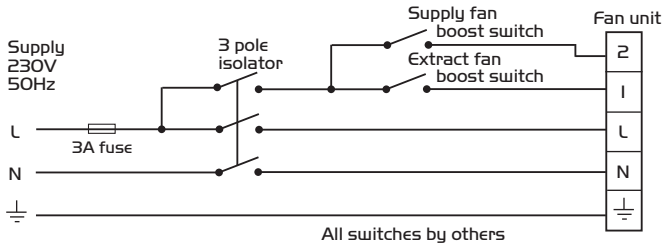

The two fans are pre-wired into an external wiring box for ease of connection. (see figure 6 for connection details). All incoming mains connections must be routed through a suitable local isolator for maintenance purposes.

IMPORTANT

For good EMC engineering practice, any sensor cables or switched live cables should not be placed within 50mm of other cables or on the same metal cable tray as other cables.

3.1 Additional Control Wiring Option

Units are supplied configured to run on speeds 1 and 3. To change the duty the links may be removed and refitted to the other positions. (See table 1).

Figure 7. Circuit Board Connections.

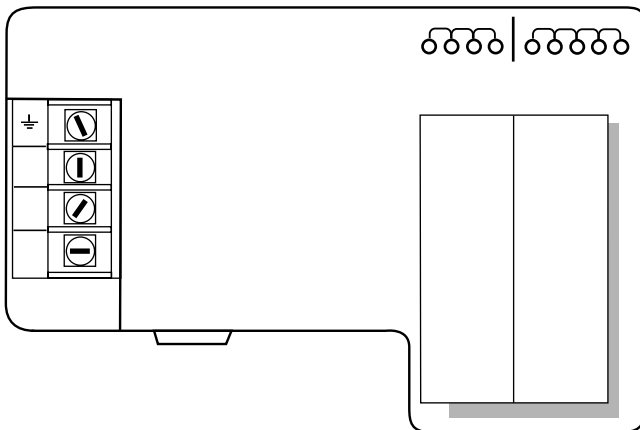

Table 1.

TRICKLE	BOOST
SPEED 1-Link B (As supplied)	SPEED 3-Link D & F (As supplied)
SPEED 2-Link C	SPEED 4-Link G
SPEED 3- Link A & C	SPEED 4-Link G

4.0 Maintenance

It is inevitable that even with filtered extract grilles as recommended in BRE digest 398 some dust, fluff etc. will pass through the filter, and which, if allowed, will build up internally on motors and impellers, shortening the life of the unit and, in severe cases, leading to overheating of the motors. Consequently, it is strongly recommended that all units are inspected and cleaned every six months.

It is recommended that the drip-tray and the heat-exchanger should be inspected, cleaned and disinfected at regular intervals to prevent a build-up of mould and bacterial growth.

5.0 Cleaning

Remove covers and carefully clean out interiors as necessary. To clean the filter, remove from the unit and wash in tepid water to which a little mild detergent has been added. Shake out excess water and allow to dry naturally. Replace when dry. Check for damage and security of components. Refit covers.

To remove the drip-tray and the heat-exchanger, disengage the retainer clips. Take care not to let the drip-tray and the heat-exchanger drop down. Clean by washing the parts in tepid water with suitable disinfectant.

Allow to dry naturally before refitting back into the unit.

6.0 Replacement of Parts

Should any component need replacing Nuaire keep extensive stocks for quick delivery. Ensure that the unit is electrically isolated, before carrying out any work.

When ordering spare parts, please quote the serial number of the unit and the ARC number of the purchase if possible. (This information will be available on the fan label).

7.0 Warranty

The 5 year warranty starts from the day of delivery and includes parts and labour for the first year and parts only for the remaining four years. This warranty is conditional on planned maintenance being undertaken.

8.0 Service Enquiries

Nuaire can assist you in all aspects of service. Our service department will be happy to provide any assistance required, initially by telephone and if necessary arrange for an engineer to call.

**Telephone 087 0500 2555
Fax 087 0500 2666**

II.O Connection of Drain Pipe

The unit needs a drain pipe to function correctly.

Remove the lid via the screws and decide which side the drain pipe is to be connected. On the same side as where the drain pipe is to be connected, fit a 135 degree elbow to the copper pipe and connect a 22mm dia. plastic pipe to the other side of the elbow and through the supplied "O" ring in the outer wall. This is the drain pipe.

Seal the internal perimeter between the drain pipe and "O" ring with silicone to prevent air leakage.

On the other copper pipe place the end stop as shown in the diagram below and place the supplied rubber bung into the opposite hole in the outer casing to prevent air leakage.

Replace the lid and hand tighten all the fixing screws.

Figure 8. Drain pipe configuration options.

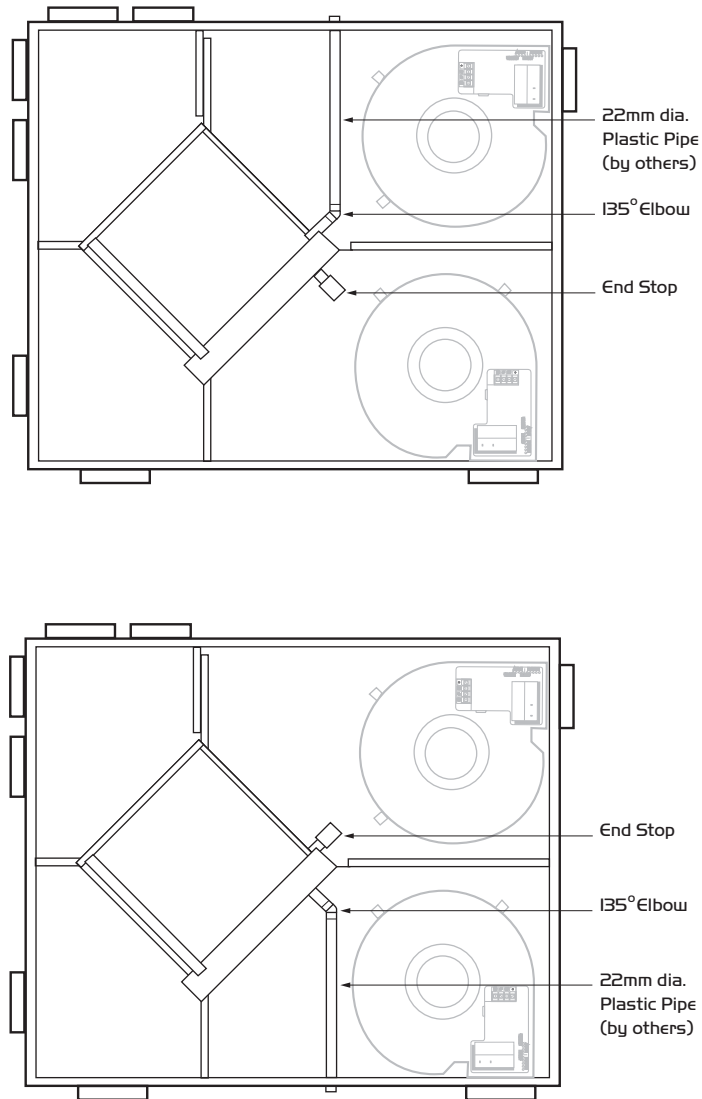



DECLARATION OF INCORPORATION AND INFORMATION FOR SAFE INSTALLATION, OPERATION AND MAINTENANCE

We declare that the machinery named below is intended to be assembled with other components to constitute a system of machinery. The machinery shall not be put into service until the system has been declared to be in conformity with the provisions of the EC Machinery Directive.

Designation of machinery: LPXBOXAC-2
 Machinery Types: Mechanical Ventilation with Heat Recovery Unit
 Relevant EC Council Directives: 98/37/EC as amended by 98/79/EC (Machinery Directive)
 Applied Harmonised Standards: BS EN ISO 12100-1, BS EN ISO 12100-2, EN294, EN60204-1, BS EN ISO 9001
 Applied National Standards: BS848 Parts One, Two and Five

Signature of manufacture representatives:

Name:	Position:	Date:
1) C. Biggs	 Technical Director	20. 07. 07
2) W. Glover	 Manufacturing Director	20. 07. 07

INFORMATION FOR SAFE INSTALLATION, OPERATION AND MAINTENANCE OF NUAIRE VENTILATION EQUIPMENT

To comply with EC Council Directives 98/37/EC Machinery Directive and 2004/108/EC (EMC).

To be read in conjunction with the relevant Product Documentation (see 2.1)

1.0 GENERAL

1.1 The equipment referred to in this Declaration of Incorporation is supplied by Nuairé to be assembled into a ventilation system which may or may not include additional components.

The entire system must be considered for safety purposes and it is the responsibility of the installer to ensure that all of the equipment is installed in compliance with the manufacturers recommendations and with due regard to current legislation and codes of practice.

2.0 INFORMATION SUPPLIED WITH THE EQUIPMENT

- 2.1 Each item of equipment is supplied with a set of documentation which provides the information required for the safe installation and maintenance of the equipment. This may be in the form of a Data sheet and/or Installation and Maintenance instruction.
- 2.2 Each unit has a rating plate attached to its outer casing. The rating plate provides essential data relating to the equipment such as serial number, unit code and electrical data. Any further data that may be required will be found in the documentation. If any item is unclear or more information is required, contact Nuairé.
- 2.3 Where warning labels or notices are attached to the unit the instructions given must be adhered to.

3.0 TRANSPORTATION, HANDLING AND STORAGE

- 3.1 Care must be taken at all times to prevent damage to the equipment. Note that shock to the unit may result in the balance of the impeller being affected.
- 3.2 When handling the equipment, care should be taken with corners and edges and that the weight distribution within the unit is considered. Lifting gear such as slings or ropes must be arranged so as not to bear on the casing.
- 3.3 Equipment stored on site prior to installation should be protected from the weather and steps taken to prevent ingress of contaminants.

4.0 OPERATIONAL LIMITS

- 4.1 It is important that the specified operational limits for the equipment are adhered to e.g. operational air temperature, air borne contaminants and unit orientation.
- 4.2 Where installation accessories are supplied with the specified equipment e.g. wall mounting brackets. They are to be used to support the equipment only. Other system components must have separate provision for support.
- 4.3 Flanges and connection spigots are provided for the purpose of joining to duct work systems. They must not be used to support the ductwork.

5.0 INSTALLATION REQUIREMENTS

In addition to the particular requirements given for the individual product, the following general requirements should be noted.

- 5.1 Where access to any part of equipment which moves, or can become electrically live are not prevented by the equipment panels or by fixed installation detail (eg ducting), then guarding to the appropriate standard must be fitted.
- 5.2 The electrical installation of the equipment must comply with the requirements of the relevant local electrical safety regulations.
- 5.3 For EMC all control and sensor cables should not be placed within 50mm or on the same metal cable tray as 230V switched live, lighting or power cables and any cables not intended for use with this product.

6.0 COMMISSIONING REQUIREMENTS

- 6.1 General pre-commissioning checks relevant to safe operation consist of the following:
 Ensure that no foreign bodies are present within the fan or casing.
 Check electrical safety. e.g. Insulation and earthing.
 Check guarding of system.
 Check operation of Isolators/Controls.
 Check fastenings for security.
- 6.2 Other commissioning requirements are given in the relevant product documentation.

7.0 OPERATIONAL REQUIREMENTS

- 7.1 Equipment access panels must be in place at all times during operation of the unit, and must be secured with the original fastenings.
- 7.2 If failure of the equipment occurs or is suspected then it should be taken out of service until a competent person can effect repair or examination. (Note that certain ranges of equipment are designed to detect and compensate for fan failure).

8.0 MAINTENANCE REQUIREMENTS

- 8.1 Specific maintenance requirements are given in the relevant product documentation.
- 8.2 It is important that the correct tools are used for the various tasks required.
- 8.3 If the access panels are to be removed for any reason the electrical supply to the unit must be isolated.
- 8.4 A minimum period of two minutes should be allowed after electrical disconnection before access panels are removed. This will allow the impeller to come to rest.
NB: Care should still be taken however since airflow generated at some other point in the system can cause the impeller to "windmill" even when power is not present.
- 8.5 Care should be taken when removing and storing access panels in windy conditions.

Technical or commercial considerations may, from time to time, make it necessary to alter the design, performance and dimensions of equipment and the right is reserved to make such changes without prior notice.