



ES-ISCT

Twin Fan Speed Control

Product Manual

1.0 ES-ISCT Ecosmart Controls

The ES-ISCT controls are designed to provide speed control for selected Nuair fans operating in run and standby systems. The units will also provide 12 hours duty sharing operation and will automatically switch over to the standby fan if the operating fan fails.

The control is only available for three phase electrical supply.

The case material is of Aluzinc corrosion resistant steel, incorporates a frequency inverter, Ecosmart control board and is directly compatible with the Ecosmart range of user controls, time clocks, 'stats and sensors.

2.0 Selection, Dimensions and Weights

Select a control by matching the unit full load current with the control code i.e. control code ES-ISCT3.3A is suitable for a fan with a maximum full load current of 3.3A. The Inverter overload is pre-set at the rating plate value, if a lower setting is required fit an appropriately sized overload relay to the output contactor and adjust accordingly.

Figure 1. Dimensions and Drill Pattern (nts)

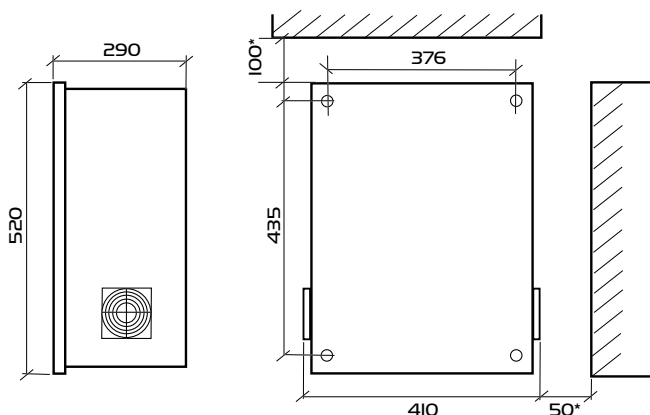

* Minimum distance between ventilation grilles and any obstructions.

Product code	Weight Kg
ES-ISCT1.2A to ES-ISCT8.8A	15
ES-ISCT12.5A to ES-ISCT23.1A	17

IMPORTANT

Isolation - Before commencing work make sure that the unit is electrically isolated from the mains supply.

3.0 Handling

Upon receipt of the unit an inspection should be made. Report any damages immediately. and before commencement of lifting ensure that normal equipment safety checks have been carried out.

Always handle with care to avoid damage and distortion, and where lifting slings are employed use spreaders to ensure slings do not come into contact with the unit case, or control pack. (See figure 3).

Correctly position slings to avoid twisting of the unit case and observe the centre of gravity before the final lift is made.

Figure 3. Use of slings via spreaders

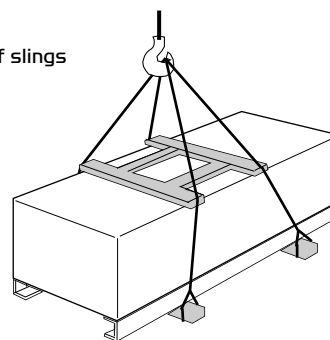

4.0 General Installation

The installation must be carried out by competent personnel in accordance with the appropriate authority and conforming to all statutory and governing regulations i.e. IEE, CIBSE, COHSE, HVCA etc.

The Ecosmart control is designed to be wall mounted and to be installed indoors, away from any water spray or steam generating source. Fix or mount in upright position to a secure vibration free vertical surface.

(See figures 1 and 2). Ensure the ventilation grilles are free of obstruction.

If the unit is installed outdoors, the weathering cover ES-ISCT-WP must be used to provide weather protection.

IMPORTANT

The operating range is 0°C to 35°C, up to 85% relative humidity (non condensing).

Installation in unventilated loft is not recommended.

4.1 Mechanical Installation

For ease of installation, remove the front cover and disconnect any cooling fans fitted. Remove the control casing from the base, offer the base to the wall (or mark from the drill pattern). Drill and fix the base to the wall using appropriate fasteners.

It may be easier to connect the field wiring at this stage.

Reassemble the case ensuring that cooling fans are reconnected.

4.2 Electrical

The mains power supply to the controller must appropriately sized and installed via a local isolation switch (by others). The isolator must also accommodate the 230V switched live (if used).

The mains supply from the ecosmart controller to the fan must be appropriately sized, not exceeding 30 Metres and must be a screened power cable, earthed at both ends. A four point glanding plate is formed from the base of the control and in order to maintain EMC compliance, an EMC glanding kit is supplied.

Figure 4.

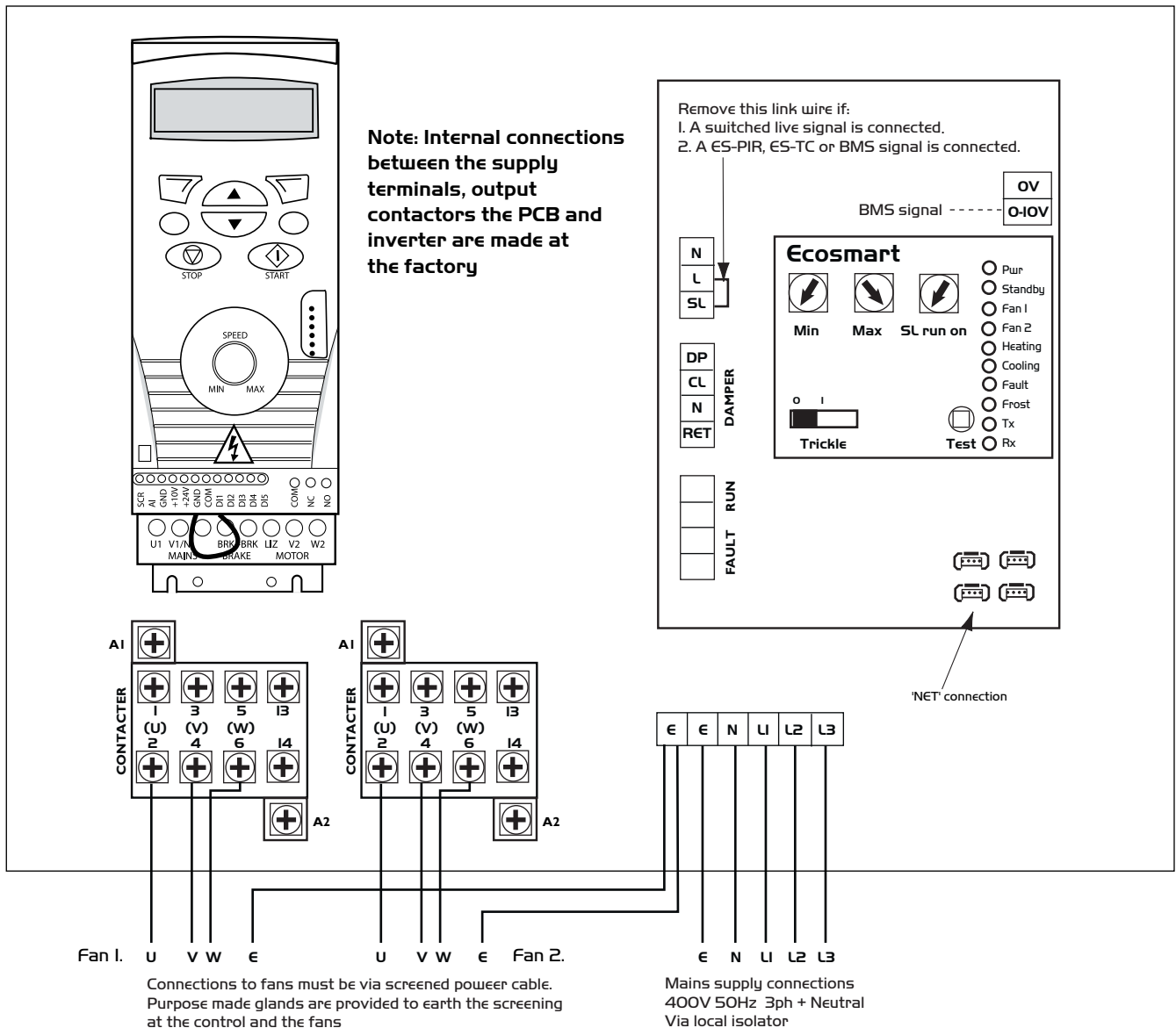

IMPORTANT

* Motors of 4kW and above must be connected in Delta

IMPORTANT

The screening of the power cable must be continuous. Bridge any breaks (e.g. at local isolators) using braided earthing cable. Ensure the screening is earthed at both ends.

IMPORTANT

To minimise the possibility of Electro Magnetic interference:

- Always install screened cable between the control and the fan, maximum length 30 metres. Please consult Nuaira if a longer cable run is needed.
- This product must be earthed and always 'earth' the screened cable at both ends.

Ensure that ALL earth connections are the same potential. Cable glands are provided.

- Always keep mains supply cables and motor supply cables separate and DO NOT install any data cable or low voltage cable in the same containment as mains carrying cables.

4.3 Control Connections

a) Mains connections

Mains cables should be suitably sized and terminated at terminals shown on the appropriate diagram.

b) Control Connections

Figure 5. 'Net' connection for Ecosmart devices.

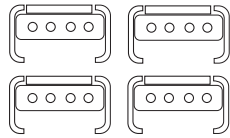

Net - the 4 IDC plug-in connectors are provided for the connection of compatible sensors, manual controls and for linking the fans together under a common control. If more than 4 connections are required, the junction box (product code ES-JB) should be used (see data cable installation).

c) Switched Live (SL) terminal

Figure 6.

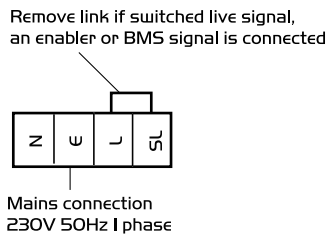

A signal of 100-230V a.c. will activate the fan from either its off state or trickle state (see setting to work-trickle switch). When the SL is disconnected the fan will over-run for 1 - 60 minutes. (see figure 10).

Do not take this signal from an isolating transformer.

d) Damper connections

Figure 7a. Drive open/ Spring close.

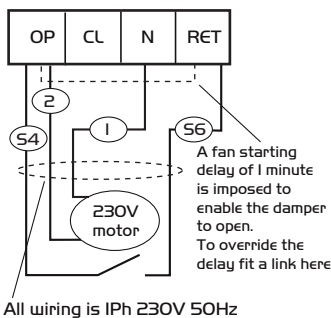
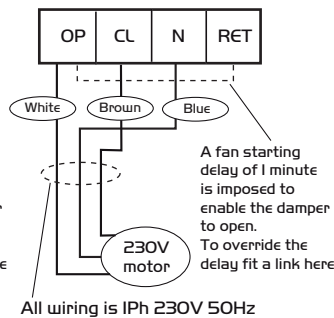

Figure 7b. Drive open/ Drive close.



- OP** - 230V 50Hz IA max supply to open the damper
 - CL** - 230V 50Hz IA max supply to close the damper
 - N** - Neutral supply to damper
 - RET** - 230V ac return signal from the damper limit switch indicates the damper has reached its operating position. If the return signal is not present, the fan will wait for 1 minute before starting.
- Note: If a damper is not fitted, connect a link wire from OP to RET. This will cancel the delay.

e) Volt Free Relay Contacts

Figure 8.

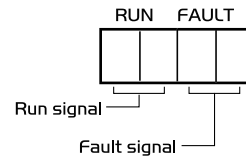

Note that the volt free contacts are not fused. If these are used to power any external equipment, the installer must provide adequate fusing or other protections.

These contacts are rated at 5A resistive, 0.5A inductive. **Run connections** - These contacts are closed when the fan is running.

Fault connections - No fault = the contacts are closed. **Fault** = the contacts are opened.

f) Data cable installation

A 4-core SELV data cable is used to connect devices. Do not run data cable in the same conduit as the mains cables and ensure there is a 50mm separation between the data cable and other cables. The maximum cable run between any two devices is 300m when it is installed in accordance with the instructions.

Please note that the total data cable length used in any system must be less than 1000m. Keep the number of cable joints to a minimum to ensure the best data transmission efficiency between devices.

g) Maximum number of devices

The maximum number of devices (including fans) that can be connected together via the cable is 32, irrespective of their functions.

h) Other low voltage cables e.g. BMS signal

Follow the basic principle (as f). Keep the cable run as short as possible, less than 50 metres. If the cable is longer than 12m, we recommend using screened cable with the screening grounded at one end only (preferably at the inverter end).

j) BMS input signals

The BMS connection is made with a plug-in connector via the socket (See figure 9). To ensure the connection is made only by suitably qualified and authorised personnel the plug is not supplied.

It is available from R S Components, Part No. 403-875 or Farnell, Part No. 963-021.

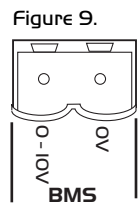

Reversal of the BMS connection will damage the control.

The system's response to a 0-10V dc BMS signal is given in the table below.

Note the BMS signal will override any sensors and user control connected in the system. The voltage tolerance is +/- 125mV and is measured at the fans terminal.

	Ventilation mode	Cooling mode*	Heating mode*
Local control	0.00	-	-
OFF / trickle	0.25	-	-
Speed 1	0.50	0.75	1.00
Speed 2	1.50	1.75	2.00
Speed 3	2.50	2.75	3.00
Speed 4	3.50	3.75	4.00
Speed 5	4.50	4.75	5.00
Speed 6	5.50	5.75	6.00
Speed 7	6.50	6.75	7.00
Speed 8	7.50	7.75	8.00
Speed 9	8.50	8.75	9.00
Speed 10	9.50	9.75	10.00

* Only available on relevant unit.

4.4 Setting to Work

IMPORTANT

Isolation - Before commencing work make sure that the unit, switched live and Nuair control are electrically isolated from the mains supply.

Warning - Inverter Speed Control

An Inverter is used to provide speed control. When the fan is isolated, allow 5 minutes for the capacitors in the inverter to discharge before commencing any work on the unit.

a) Electrical

Using the Test button

The test button allows the blower within the unit to be checked for its operation. If the fan is running already, press the button once to stop the fan, press again to switch on the fan.

Note that the fan will return to normal operation after 30 seconds.

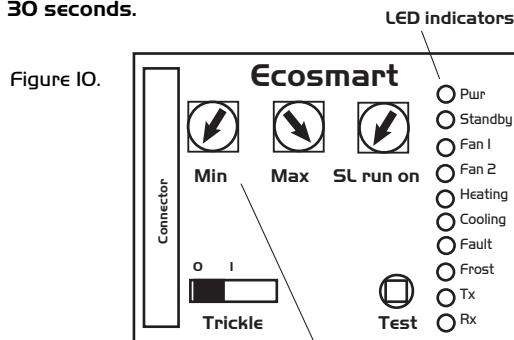

- MIN = Minimum speed adjustment
- MAX = Maximum speed adjustment
- SL = Switched Live Run-On
- Run on = Timer adjustment
- TRICKLE = Selects trickle running: 0 = off, 1 = selected
- TEST = Test button

LED Indication

- PWR GREEN: Power on & OK,
- Standby LED on when fan is not running.
- Fan 1 GREEN: Fan 1 is running, RED: Fan 1 faulty.
- Fan 2 GREEN: Fan 2 is running, RED: Fan 2 faulty.
- Heating* GREEN: Heating selected RED:
- Cooling* Not applicable. See note.
- Fault LED on when a fault is present on unit.
- Frost* Not applicable. See note.
- Tx LED on when the controller is transmitting data.
- Rx LED on when the controller is receiving data.

* Note that the control panel is common to all the Ecosmart products and will have indicators for functions that are not available in this particular fan. However these indicators will not be illuminated.

Settings

Setting the maximum air flow

- i) Ensure the power supply is switched off and that a link wire is connected from the supply L to the SL terminal. Unplug all items connected to the 'Net' connectors.
- ii) Switch on the power supply.
- iii) Wait for the fan to reach steady condition. Measure the airflow using standard commissioning instruments at a suitable point in the ductwork. If adjustment is required, rotate the pot marked 'MAX' to obtain the desired airflow. Remove the link wire if not required - see "wiring (c)".

Setting the minimum/trickle airflow rate (nominal 20%)
 i) Repeat the same procedure as for maximum airflow above but without the link wire between supply L and SL terminal. Ensure the trickle switch is in the 'ON' position. Adjustment must be made on the pot marked 'Min'.

ii) Note that the minimum setting (nominally 20%) must be below the maximum setting, otherwise minimum setting will be automatically set to be the same as the maximum.

iii) The minimum speed set is the trickle speed at which the fan operates.

Note: The working speed range of the user control and sensors is between the minimum and maximum set points.

5.0 Maintenance

Maintenance Intervals

The first maintenance should be carried out three months after commissioning and thereafter at twelve monthly intervals. These intervals may need to be shortened if the unit is operating in adverse environmental conditions, or in heavily polluted air.

Lubrication

There are no items requiring lubrication.

General Cleaning and Inspection

General cleaning and inspection – Clean and inspect the exterior of the unit, remove covers and carefully clean out any dust deposits. Check security of all components and terminals, remove fan filters and clean or replace as necessary. Refit covers.

Replacement of Parts

Should any component need replacing Nuair keep extensive stocks for quick delivery. When ordering spare parts, please quote the serial number of the unit and the ARC number of the purchase if possible. (This information will be available on the fan label).

Warranty

The 5 year warranty starts from the day of delivery and includes parts and labour for the first year.

The remaining 4 years covers replacement parts only. This warranty is conditional on planned maintenance being undertaken.

Service Enquiries

Nuair can assist you in all aspects of service. Our service department will be happy to provide any assistance required, initially by telephone and If necessary arrange for an engineer to call.

Telephone 029 2085 8585
Fax 029 2085 8586

Technical or commercial considerations may, from time to time, make it necessary to alter the design, performance and dimensions of equipment and the right is reserved to make such changes without prior notice.