

ECOSMART SQRBO - SUPPLY OR EXTRACT

LOW DEPTH SUPPLY OR EXTRACT FANS THAT AUTOMATICALLY
REACT TO THE ENVIRONMENTAL CONDITIONS.

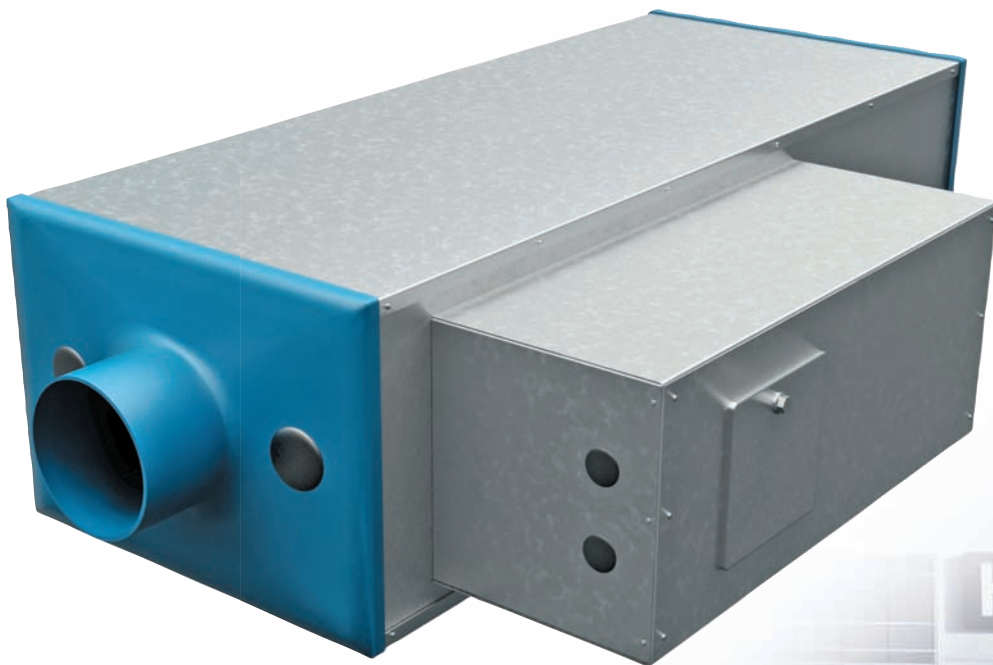

BENEFITS

ENERGY EFFICIENT

All models have Ecosmart controls which provide the most energy efficient and cost effective solution by varying fan speed to suit the required units.

EXACT VENTILATION

Low voltage plug-in sensors allow the extract rate to be automatically adjusted to suit the rooms specific requirement. Plug-in sensors and controls reduce the installation time on site.

COMPACT DESIGN

Low case height makes this unit ideal for restricted ceiling spaces. Unique, removable mounting bracket and integral AV mounts ensure quick and efficient installation and maintenance.

QUIETER UNITS

Casing is fully lined to provide high acoustic and thermal insulation properties ensuring very low noise.

COST EFFECTIVE

All sensors are safe extra low voltage therefore eliminating the need for expensive main wiring between fan and controls.

EFFICIENT PACKAGED SOLUTION

All fans and controls are an integrated package providing a simple to select and install system – eliminating the need for traditional control panels.

SIMPLE COMMISSIONING

On board control pad allows for pre-setting of minimum and maximum fan speeds to suit design requirements – no main balancing damper required.

DESIGN FLEXIBILITY

Available in 6 case sizes, supply unit with LPHW or electric heater.

ANCILLARIES

Full range of heat exchangers, attenuators, smart heaters and cowls etc. are available to complete your installation.

WARRANTY

Ecosmart sqrubo has a 5 year warranty.

For a more comprehensive description of Ecosmart Sqrubo supply and extract units please see the Nuair commercial catalogue.

Code descriptions

ESS 2 - E

1 | 2 | 3
1 2 3

1. ESS = Ecosmart Sqrubo supply fan
2. Case Size/Curve Reference
3. No suffix = without heater
E = With electric heating
L = Heating
2L = with 2 row LPHW heating

Note: Performance curves make allowance for the internal filter and heater battery and you only need apply the resistance external to the unit and any additional units eg. HX, Filter etc.

ESSE 2-WP

1 | 2 | 3
1 2 3

1. ESSE = Ecosmart Sqrubo extract fan
2. Case Size/Curve Reference
3. WP = Weatherproof enclosure

ECOSMART SUPPLY & EXTRACT VENTILATION SYSTEM

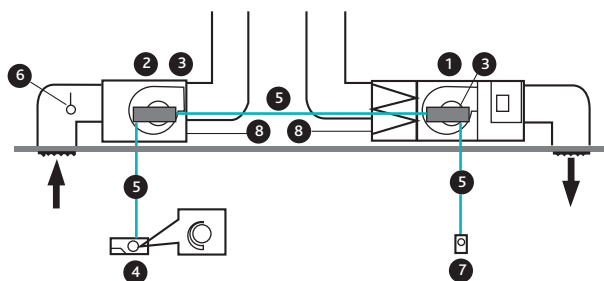

- | | |
|---|-----------------------------------|
| 1 Supply Unit | 6 CO2 Sensor (optional) |
| 2 Extract Unit | 7 PIR (Occupancy Sensor) optional |
| 3 Integral Controls | 8 230V electricity supply to fan |
| 4 User Controls (on/off, speed, heating) or BMS control | |
| 5 Safe Extra Low Voltage (SELV) 12V Cable | |

CONVENTIONAL SUPPLY & EXTRACT VENTILATION SYSTEM

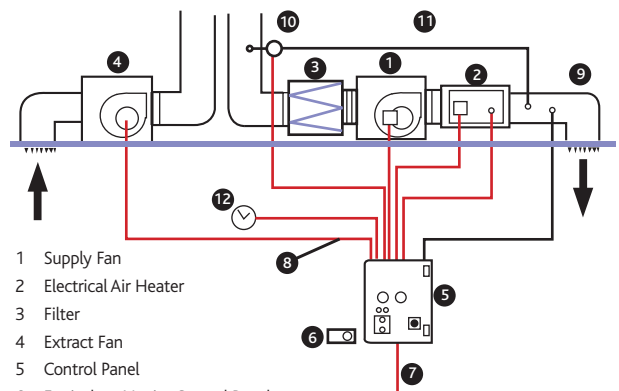

- | | |
|--|------------------------|
| 1 Supply Fan | 9 Temperature Switch |
| 2 Electrical Air Heater | 10 Air Pressure Switch |
| 3 Filter | 11 PVC Tubing |
| 4 Extract Fan | 12 Time Clock |
| 5 Control Panel | |
| 6 Equivalent Nuair Control Panel (User Control) for comparative purposes | |
| 7 230V/400V Electrical Supply | |
| 8 Various Control & 230v/400v Electricity Cabling | |

AIR HANDLING UNITS (AHU'S)

ECOSMART SQRUBO

TECHNICAL INFORMATION

PERFORMANCE - ECOSMART SQRUBO

Ecosmart Sqrubo Supply

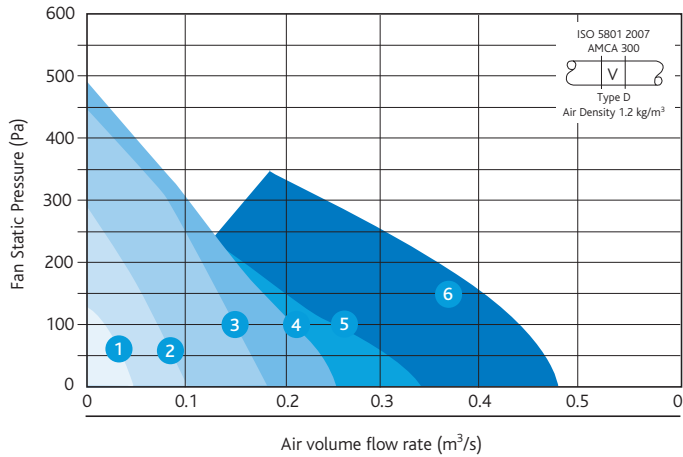

PERFORMANCE - ECOSMART SQRUBO

Ecosmart Sqrubo Extract

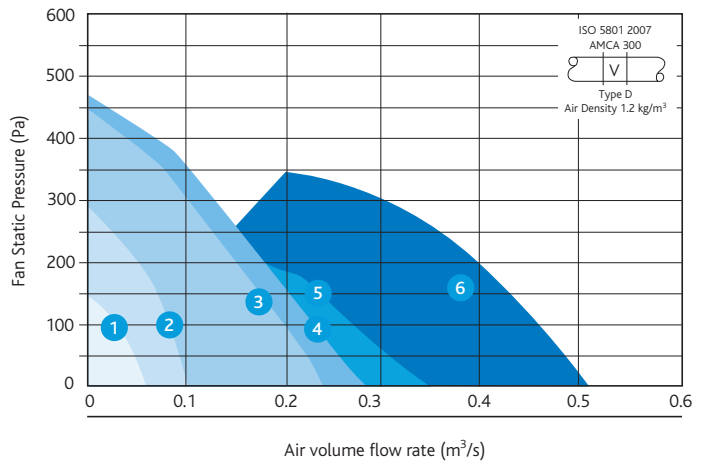

PERFORMANCE - ECOSMART SQRUBO SUPPLY

ELECTRICAL & SOUND

Curve	Code	Phase	RPM	Motor Power (kW)	Electric Heater (kW)	LPHW		FLC (amps)	Inlet/Outlet Type	Sound Power levels (dB re 10-12W) Octave Band mid frequency (Hz)						Breakout dBA@3m	
						L	2L			125	250	500	1K	2K	4K		8K
1	ESS1-E	1	2724	0.083	1.0	-	-	0.32	I	61	62	61	49	43	34	26	30
	ESS1	1	-	-	-	-	-	0.32	O	69	62	63	51	45	42	32	30
2	ESS2-E	1	2285	0.095	1.5	-	-	0.34	I	62	63	63	55	53	44	34	34
	ESS2-L/2L	1	-	-	-	3	4.5	0.34	O	70	66	66	59	57	53	42	34
3	ESS3-E	1	2544	0.19	2.0	-	-	0.72	I	67	72	71	63	60	54	46	42
	ESS3-L/2L	1	-	-	-	4.5	6	0.72	O	74	73	74	68	67	64	53	42
4	ESS4-E	1	2313	0.24	3.0	-	-	0.92	I	68	72	71	67	63	60	56	43
	ESS4-L/2L	1	-	-	-	5	8.5	0.92	O	74	74	74	72	71	68	64	43
5	ESS5-E	1	2313	0.26	4.5	-	-	0.92	I	73	71	72	67	63	62	58	43
	ESS5-L/2L	1	-	-	-	5.5	10	0.92	O	79	74	76	72	72	69	66	43
6	ESS6-E	1	1110	0.46	12*	-	-	2.95	I	71	67	59	60	56	51	46	45
	ESS6-2L	1	-	-	-	-	12	2.95	O	76	74	73	73	71	67	62	45

Note: there is no LPHW coil available for size 1 (ESS1). Unit has facility to open a remote motorised damper if frost protection is required.

*3 - phase electrical supply required to electric heating coil.

PERFORMANCE - ECOSMART SQRUBO EXTRACT

ELECTRICAL & SOUND

Curve	Code	Phase	RPM	Motor Power (kW)	FLC (amps)	SC (amps)	Data Type	Sound Power levels (dB re 10-12W) Octave Band mid frequency (Hz)						Breakout dBA@3m	
								125	250	500	1K	2K	4K		8K
1	ESSE1	1	2724	0.083	0.32	0.32	I	63	59	63	50	45	37	27	30
								O	68	62	65	51	48	44	34
2	ESSE2	1	2285	0.095	0.34	0.34	I	64	64	66	57	52	57	37	34
								O	71	66	68	61	56	65	44
3	ESSE3	1	2544	0.19	0.72	0.72	I	70	75	75	66	63	57	49	42
								O	76	75	76	70	69	66	55
4	ESSE4	1	2313	0.24	0.92	0.92	I	70	75	75	66	64	61	58	43
								O	76	75	79	69	69	63	65
5	ESSE5	1	2313	0.26	0.92	0.92	I	74	70	73	68	66	64	60	43
								O	78	69	77	73	72	70	66
6	ESSE6	1	1110	0.66	2.95	2.95	I	71	67	59	60	56	51	46	45
								O	76	74	73	73	71	67	62

The electrical and sound information in the table is nominal. Breakout dBA@3m is spherical, free field.

Start currents (sc) are DOL other than for motors of 4 kW and above which is star delta. * Motor electrical supply, 1=1 phase (230V, 50Hz) 3=3phase (400V, 50Hz).

Unit has facility to operate motorised damper fan frost protection. I = Induct inlet. O = Induct outlet.

Please note: With Ecosmart, Ecosmart BMS & Ecosmart Commissioning options the units are pre-programmed with a soft start facility.

CONSULTANTS SPECIFICATION

ECOSMART SQRBO SUPPLY & EXTRACT FANS

SPECIFICATION

The unit shall be configured and arranged as detailed on the drawings and in accordance with the schedule of equipment.

The unit shall be manufactured from acoustically lined, heavy gauge pre-galvanised, corrosion resistant steel. The units shall provide exceptional thermal and acoustic insertion. The general construction is to class A leakage.

The unit will be manufactured to provide a low height solution to enable it to be located in low depth ceiling and floor voids. For ease of installation the unit shall be provided with a single point mounting bracket with integrated, anti vibration strips.

The fan impeller and motor shall be selected to provide the most energy efficient solution conforming to part L regulations and shall be direct drive with high efficiency motors to BS5000 as standard. The fan impeller shall be a high efficiency backward curved centrifugal design, manufactured in galvanised steel.

The contractor shall allow for all necessary ductwork transformations to and from the fan unit and any associated components in accordance with the manufacturers recommendations, DW 144 and general good practice.

The unit and ancillaries shall be of the Ecosmart Sqrbo type as manufactured by Nuaire Ltd. All other components shall be in accordance with the manufacturer's specification.

CONTROL SPECIFICATION

The fan unit shall be supplied with one of the following control options:-

ECOSMART CONTROLS

The compact Ecosmart control system complete with all necessary controls to facilitate the operation of the ventilation system. It shall be come complete with an integral factory fitted Ecosmart PCB which will control the fan unit within the desired design parameters and provide the interface between all external control devices and the unit itself.

The unit shall have the following energy saving components integrally mounted, pre-wired to interface with the purpose made PCB, all components pre-wired, configured and factory fitted by the manufacturer: -

- Integral Frequency inverter/speed controller.
- Integral maximum and minimum speed adjustment for commissioning.
- Integral adjustable run on timer.
- Integral BMS interfaces – summer/winter switching, heating control, 0-10V speed adjustment. (using ES - UCFT).
- Volt free failure and status indication.
- Integral air off temperature adjustment.
- Facility for remote temperature control.
- Integral background ventilation switch (trickle switch).
- Multiple IDC sockets for interconnection of sensors or fans using pre-plugged 4-core low voltage cable.
- Volt free frost alarm/heat demand interface.
- Frost protection/hold off stat.

COIL TYPES AND CONTROLS (SUPPLY UNIT ONLY)

- Low Pressure Hot Water.

The Low Pressure Hot Water heating coil shall be factory fitted with a 4-port valve, double regulating valve, drain cocks and air vents. The actuator controlling the 4-port valve shall be controlled via the on-board PCB by the off coil temperature sensor. All components pre-piped, assembled and tested by the manufacturers.

The control for the coils shall be fully integrated and shall maintain a constant off coil temperature. The system shall have frost protection which shall, at temperatures below 4 degrees C, fully open the 4-port valve and only start the fan when the temperature at the filter has risen above the designated set point. Unit shall have contacts which shall act as a frost alarm and/or signal boiler and circulating pumps to switch on.

ELECTRIC HEATER BATTERY (SUPPLY UNIT ONLY)

The Electric Heater Battery shall be factory fitted and pre-wired to an integral closed loop thyristor control.

The Ecosmart Supply and Extract Fan unit shall have a 5 year warranty.

All equipment to be as manufactured by Nuaire Ltd.