

OPUSXBOX - SMALL COMMERCIAL HEAT RECOVERY SYSTEM

LOW DEPTH, HEAT RECOVERY UNIT WITH MULTIPLE SPIGOTS AND ECOSMART CONTROLS.

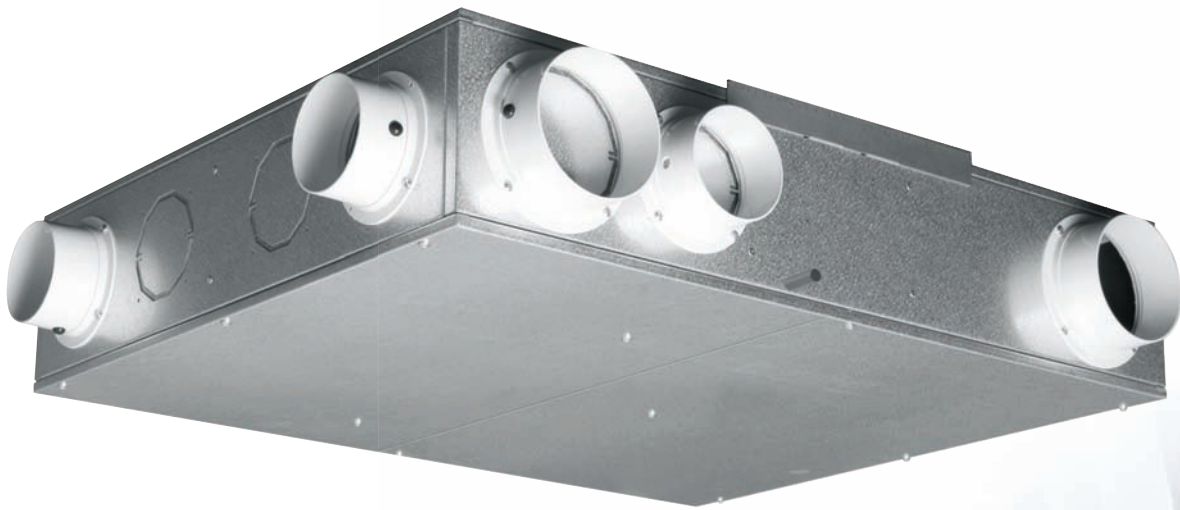

BENEFITS

LOW DEPTH 185MM

The shallowest available, ideal for applications where space is at a premium.

HIGH EFFICIENCY

Heat recovery efficiency in excess of 70% possible, this together with low watt D.C. motors gives all round energy savings.

QUIET, COMPACT & POWERFUL

Low noise levels, compact design and a high performance, provides the perfect engineering solution.

ECOSMART EFFICIENCY

Supplied with Ecosmart control, providing a simple to install, easy to commission, energy efficient solution.

PLUG AND GO

Ecosmart controls and sensors, (please refer to controls section) simply plug directly into the unit – supply and extract then respond to the conditions being monitored. An ES-CI will also be required.

FLEXIBLE SOLUTION

Supply and extract airflows are easily fine tuned using integral speed adjustment and built in balancing dampers at each spigot.

QUICK INSTALLATION

A single point fixing bracket with anti-vibration strip enables quick and easy installation.

LOW MAINTENANCE COSTS

Heat exchanger block and filters are easily removed from below and cleaned ensuring longer fan life whilst maintaining efficiencies.

QUIETEST UNIT AVAILABLE

Acoustically lined with advanced impeller technology, ensuring the quietest system possible.

5 YEAR WARRANTY

For peace of mind.

TYPICAL INSTALLATION:

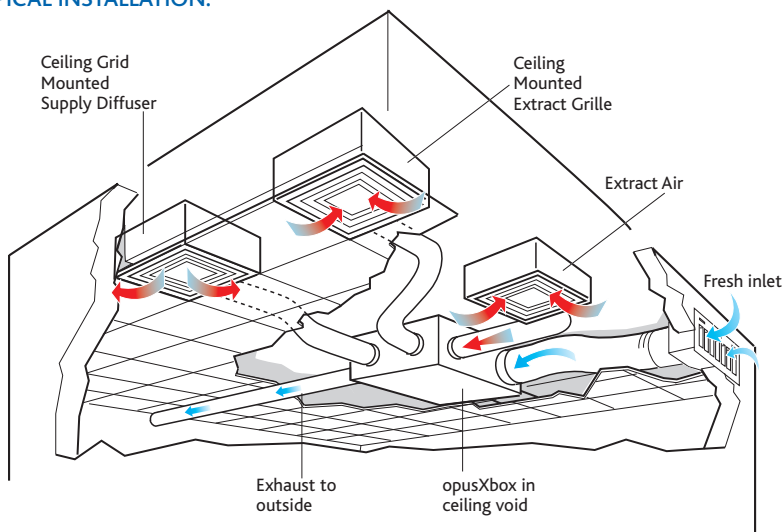

OPTIONS INCLUDE:



Easy access to filters.



Min and max speed and run on timer adjustment.

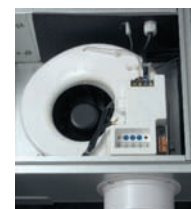

Extract fan section and commissioning controls.



Knockout spigots.

AIR HANDLING UNITS (AHU'S)

OPUSXBOX

TECHNICAL INFORMATION

PERFORMANCE - OPUSXBOX

OPUSXBOX

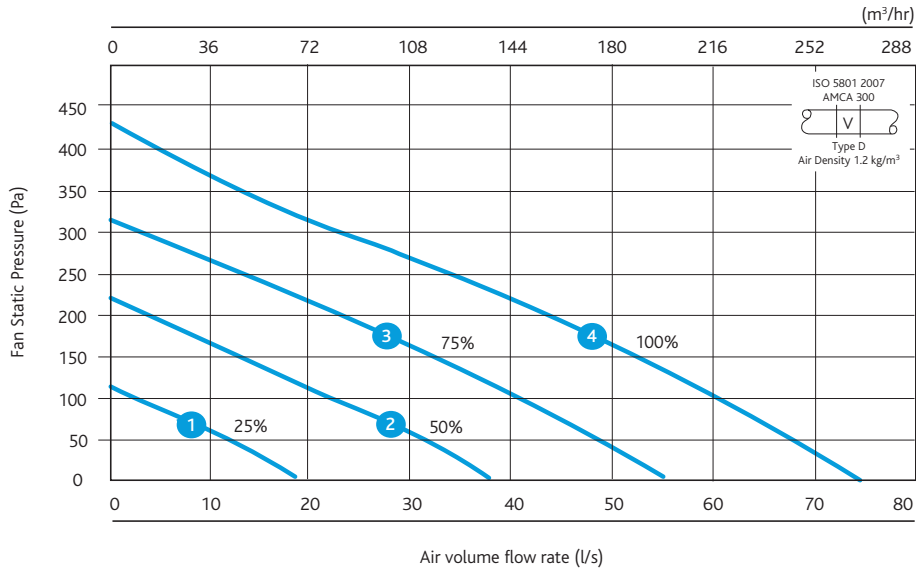

Casing



Code descriptions

OPUSXBOX

OPUSXBOX

ELECTRICAL, SOUND & WEIGHT

Curve	Ref	W**	FLC (amps)	SC* (amps)	Sound figures Induct sound power level re 1pW								Breakout dBA @3m	Weight (Kg)
					125	250	500	1K	2K	4K	8K			
1 (25%)	Supply fan	5	0.05	0.05	Inlet	29	31	28	15	16	7	2	15	25
	Extract fan	5	0.05	0.05	Outlet	19	26	23	14	8	4	4		
2 (50%)	Supply fan	17	0.1	0.1	Inlet	45	47	44	31	32	23	15	29	
	Extract fan	17	0.1	0.1	Outlet	35	42	39	30	24	12	9		
3 (75%)	Supply fan	51	0.3	0.3	Inlet	55	57	54	41	42	33	25	38	
	Extract fan	51	0.3	0.3	Outlet	45	52	49	40	34	22	19		
4 (100%)	Supply fan	120	0.7	0.7	Inlet	62	64	61	48	49	40	32	44	
	Extract fan	120	0.7	0.7	Outlet	52	59	56	47	41	29	26		
					Inlet	51	59	50	40	36	26	26		
					Outlet	68	72	76	67	67	59	49		

*Fans are programmed with a soft start, therefore starting current is the same as the FLC.

Please note step curves shown are for information purposes only and are not individual units. The units actual duty range is infinitely variable.

**W = Watts are total power consumption.

INSTALLATION

Bracket tongues engage with casing slots, then unit rotated up to align with fixing screw hole.

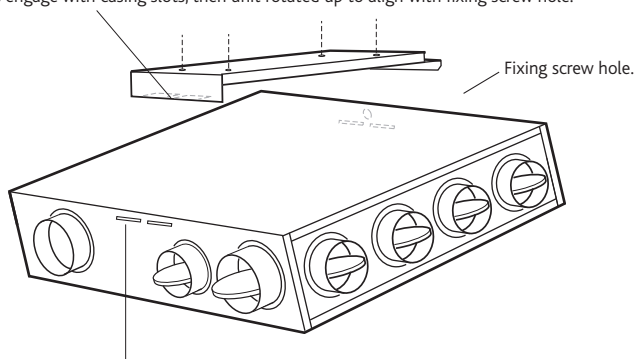

Slots in casing either side of unit to allow alternative mounting option.

OPUSXBOX CONFIGURATIONS

View from underside with cover removed

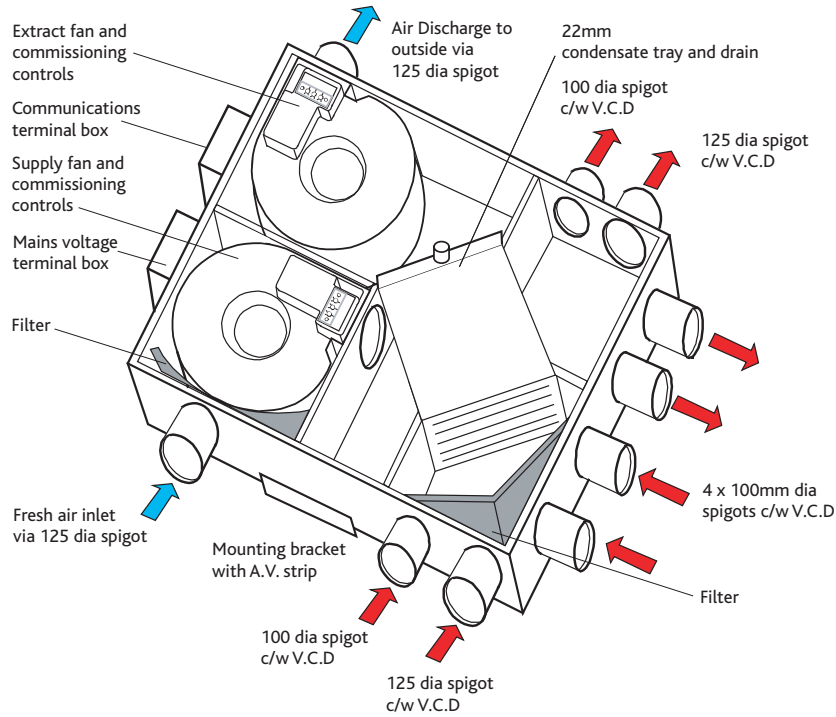

DIMENSIONS (mm) OPUSXBOX

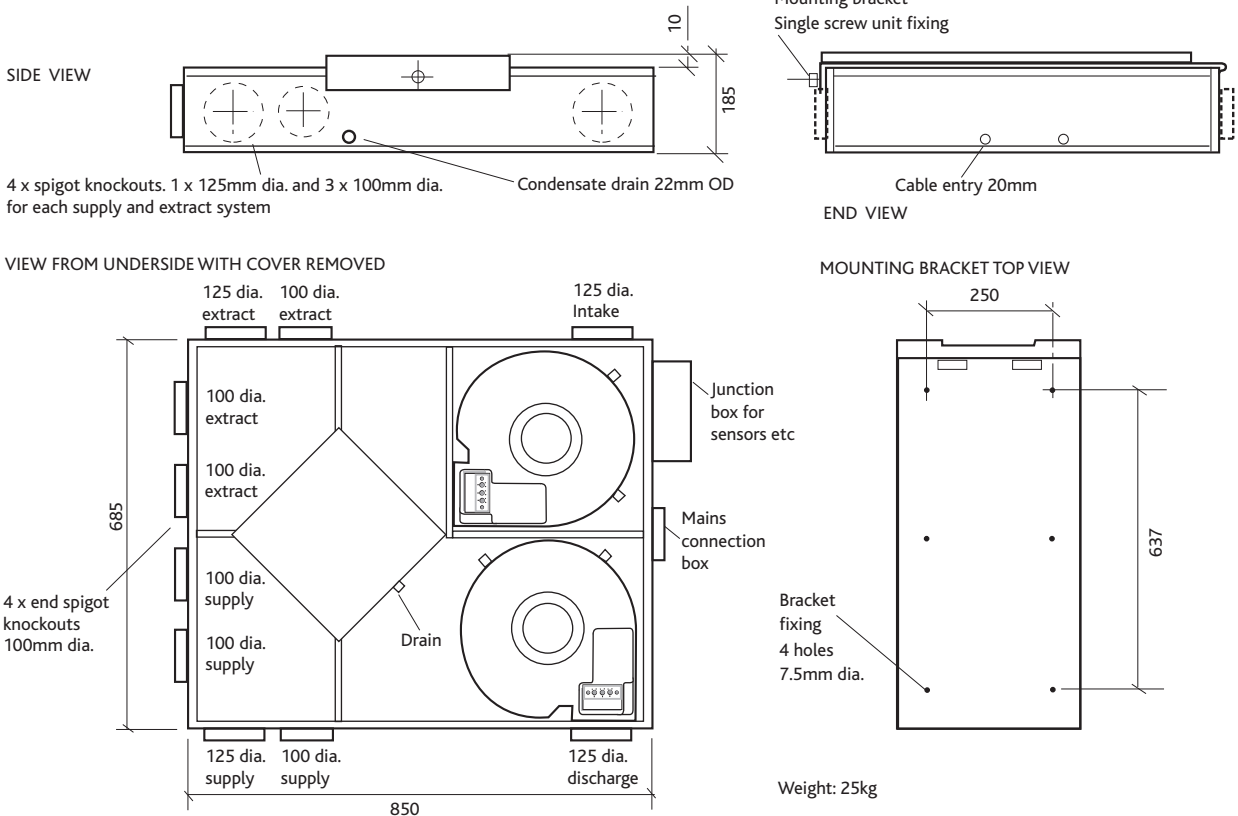

WIRING FOR OPUSXBOX

The supply and extract fan within the unit are pre-wired to an external wiring box for ease of connection. All field wiring must be routed through a suitable local isolator.

Basic wiring. Both supply and extract will run at constant speed. The fan duty is controlled via the 'Boost' setting.

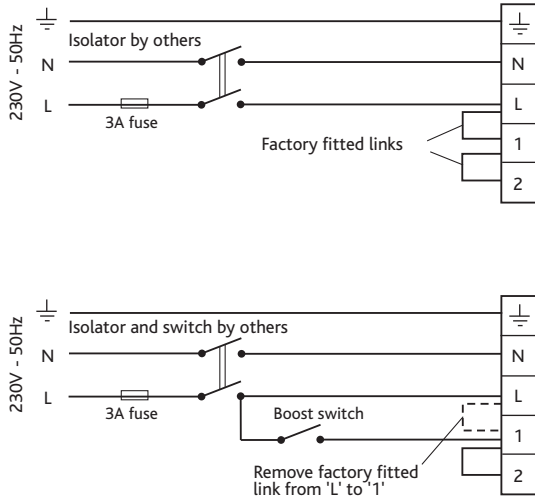

Trickle and Boost operation. Both supply and extract will run at trickle and boost speed together. Closing the boost switch will cause both fans to run at boost setting.

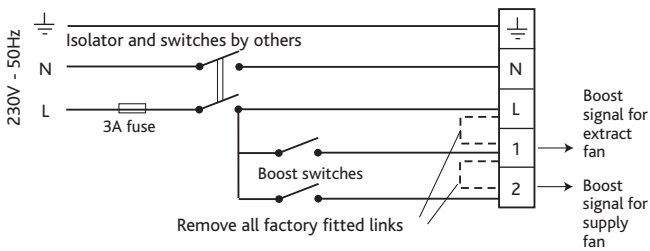

Wiring for independent boost. The supply and extract fan will trickle and boost independently.

Circuit board wiring. Other control wirings are available on each fan. Open the cover of the unit to gain access to these connections.

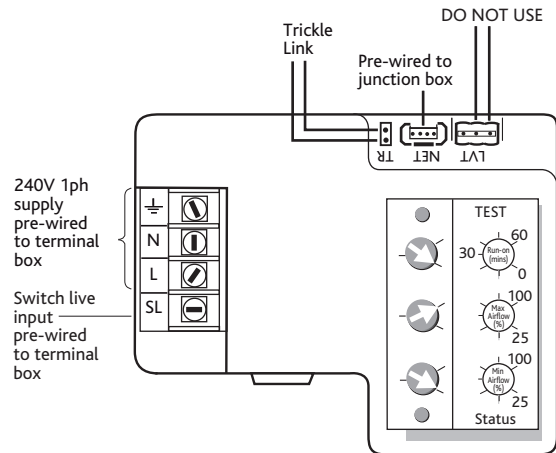

CONSULTANTS SPECIFICATION

OPUSXBOX

OPERATION

The supply and extract ventilation unit shall be as indicated on the drawings and shall be in accordance with the particular fan schedule in the specification.

Where a stand alone heater battery it will raise the temperature of the supply air to the design room temperature after the air has passed through the heat exchanger. The ventilation unit shall automatically vary the ventilation rate, as it receives signals from one of the optional interconnected sensors. When signals are received, the fan shall either vary its speed proportionally or on a trickle and boost principle.

The unit shall have the facility to commission the supply and extract fans individually via inbuilt minimum and maximum speed adjustment, the fans themselves shall have infinitely variable speed control.

OPUSXBOX - UNIT SPECIFICATION

The fans shall be acoustically lined with high density class "O" flame retardant insulation, giving extremely low noise levels. The unit shall have a heat exchanger block manufactured from aluminium with a thermal efficiency of approximately 70% which shall be protected by G2 grade filters on supply and extract. It shall come complete with a condensate drip tray and drain connection, integral minimum and maximum speed controls, run on timer and fascia mounted failure indication. The breakout noise level and power requirements shall be as detailed by the unit manufacturer and as detailed in the ventilation equipment schedule.

The unit shall have low energy, high efficiency d.c. fan/motor assemblies with sealed for life bearings.

The depth of the low profile unit shall not be greater than 185mm and shall incorporate a low profile single point mounting bracket, with a pre-stressed synthetic anti vibration strip.

The unit shall be constructed with two removable panels allowing full maintenance access to all components.

To facilitate the interconnection of branch ducts the unit shall have multiple spigot connections with integrated balancing dampers. Spigot connections provided.

OPUSXBOX CONTROL OPTIONS

All versions shall have the following functions integrally mounted within the fan unit on a purpose made PCB, all such components pre-wired and factory fitted by the manufacturer: -

- Integral speed control on supply and extract.
- Integral background ventilation control/set point.
- Integral boost ventilation control/set point.
- Integral run on timer.
- Integral S/L terminal for boost from remote switch, e.g. lightswitch.

The fan unit will have a 5 year warranty.

Units shall be the OPUSXBOX as manufactured by Nuair.