

COMMERCIAL HEAT RECOVERY

65

FAN TYPE	FAN LOCATION	MAX PERFORMANCE	PAGE
XBOXER HEAT EXCHANGE	SUPPLY/EXTRACT	0.78m ³ /s	66
XBOXER THERMAL WHEELS	SUPPLY/EXTRACT	2.0m ³ /s	80

XBOXER HEAT EXCHANGE UNITS

WIDE RANGE OF ENERGY EFFICIENT
HEAT RECOVERY UNITS WITH OPTIONAL INTEGRATED CONTROLS.

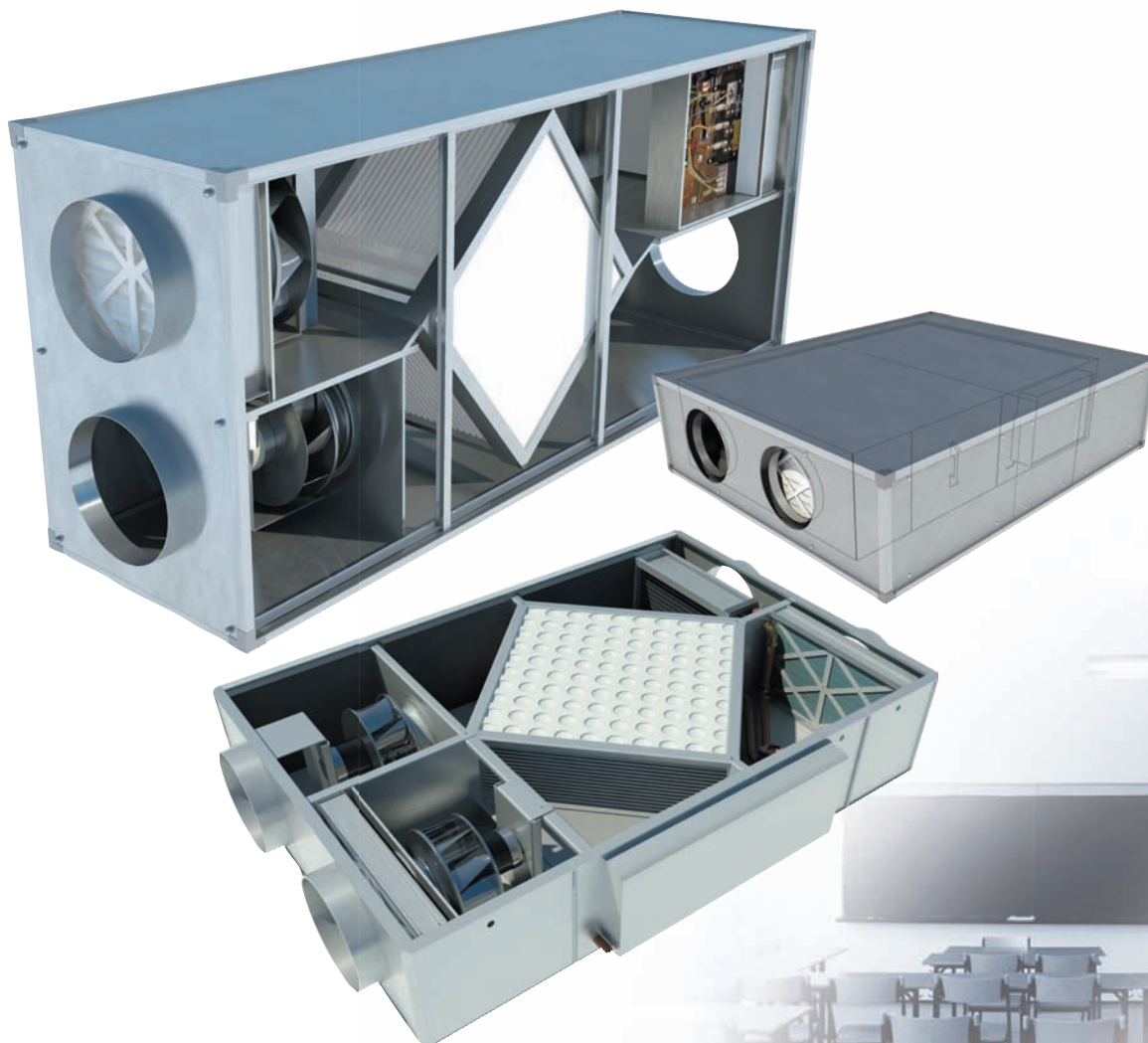

BENEFITS

HIGH EFFICIENCY

Heat exchanger efficiency of up to 70%, alongside high efficiency motors and backward curved impellers.

ENERGY EFFICIENT CONTROLS

Full Ecosmart control compatibility provides a simple 'plug & go' control solution with BMS interface and trickle and boost as standard.

NO CONTROL OPTION AVAILABLE

Now available on all sizes.

SPACE SAVING SOLUTIONS

Stacked or horizontal units, provide the most effective solution.

QUIETEST SOLUTION

Units are double skinned keeping breakout noise to the lowest possible levels.
Optional acoustic enclosure available.

WIDE RANGE

Horizontal, stacked and twinfan options available up to 5m³/s. Refer to AHU catalogue for full range.

QUICK COMMISSIONING

Integrated supply and extract fan allows precise system duty can be quickly and accurately set. (Ecosmart models only).

EASY INSTALLATION

All XB models (sizes 2 - 6) are supplied in one piece.

EASY MAINTENANCE

Left or right hand options (in direction of airflow) – will provide full access to components. For access requirements contact Nuair.

INTEGRATED SUMMER BYPASS

Operates automatically via integrated factory set temperature sensors.

WEATHERPROOF DETAIL

Can be factory or fitted on site, please refer to page 71 for details.

Note: weather proof enclosure for XB2 - XB5 is supplied as a separate component.

ADVANCED CONDENSATE REMOVAL

Miniature condensate pump option, for applications where the distance to discharge is great. Pump also enables a 'micro bore' type pipe to be used.

FILTER OPTIONS

G4 fitted as standard. Higher grade integrated filters available. Duct mounted ancillary also available.

DX COIL OPTION AVAILABLE

Please contact Nuair.

CONSTANT PRESSURE CONTROL AVAILABLE

For further details please contact Nuair.

HEATER BATTERY OPTIONS

Unit with integral battery, LPHW or electric.

ANCILLARIES

A range of ancillaries are available including manometers, bulkhead lights, view ports, drain trays & traps.

For further details please contact Nuair.

5 YEAR WARRANTY

On Ecosmart models for peace of mind. No control models have a 2 year warranty. Contact Nuair for details.

FEATURES INCLUDE:



With electric heater.



With LPHW.



Constant Pressure control option.



Filter option.



Bottom access available (XB2-5).

AIR HANDLING UNITS (AHU'S)

XBOXER HEAT EXCHANGE

TECHNICAL INFORMATION

PERFORMANCE - XBOXER HEAT EXCHANGE

XBOXER Horizontal sizes: (XB2-5) and (S1-XB and S6-XB)

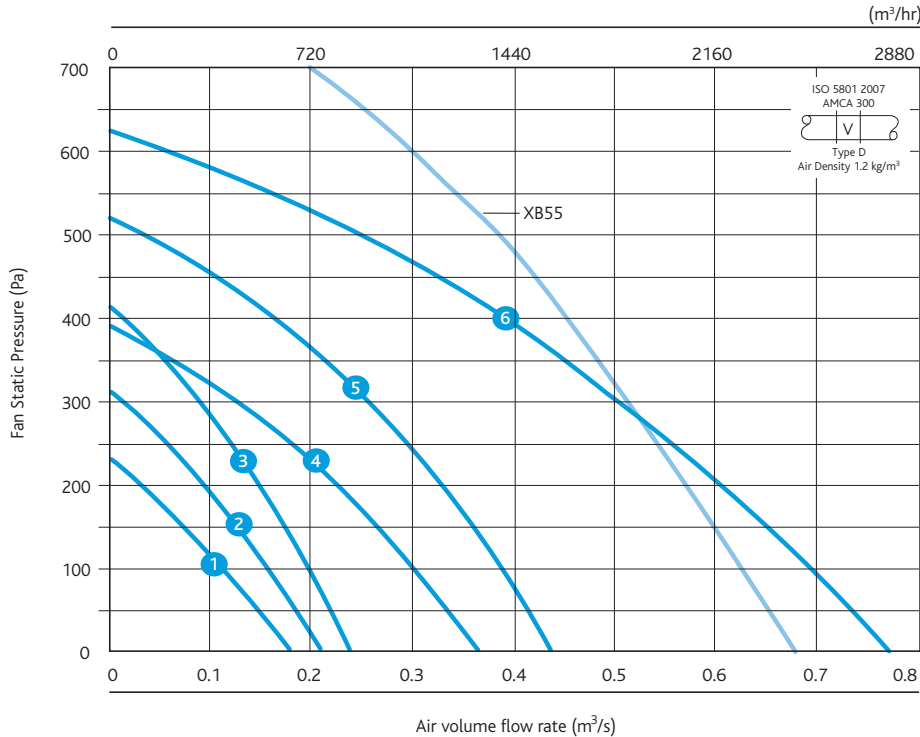

Note: refer to AHU catalogue for XB55 horizontal unit details.

Casing

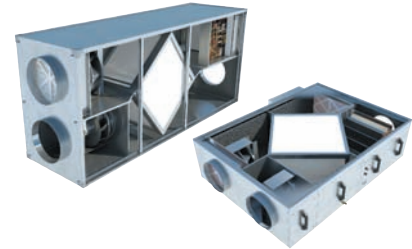

Code descriptions

XB2 - R L 2 AE

1 2 3 4 5 6

1. Xboxer (S1-XB, XB2-5 or S6-XB)
2. Curve ref.
3. Component layout
L = Left hand
R = Right hand
4. Type of heater battery fitted
N = No heater
L = LPHW
E = Electric
5. 2 = 2 row coil or 3 = 3 row coil
6. Optional Acoustic Enclosure (sizes XB2 - 5 only)

*For coil options please see page 73.

PERFORMANCE - XBOXER HORIZONTAL XB AND XBH AND STACKED XBV

ELECTRICAL, SOUND & WEIGHT

Curve Code	Phase	Motor power watts	Start current (amps)	Full load current (amps)	Electric Heater (kW)	Heater FLC (amps)	LPHW Heater (kW)	Induct Sound Power Levels dB re 1pW								Breakout dBA @3m	Weight (Kg)	
								63	125	250	500	1K	2K	4K	8K			
1 S1-XB-**	1	172	1.28	1.28	-	1.28	*	Intake	60	55	54	47	41	37	33	29	33	75
								Supply	64	67	63	59	62	60	57	53		
								Discharge	68	69	64	61	62	60	56	51		
								Extract	61	60	56	48	41	37	32	28		
2 XB2-**	1	270	1.7	1.7	4.5	18.7	*	Intake	71	71	69	66	62	54	52	49	34	153
								Supply	64	64	64	62	57	57	40	28		
								Discharge	67	70	65	69	60	59	56	49		
								Extract	60	62	53	50	47	37	29	25		
3 XB3-**	1	410	1.9	1.9	4.5	18.7	*	Intake	75	75	73	70	66	58	56	53	36	153
								Supply	68	68	68	66	61	61	44	32		
								Discharge	71	74	69	73	64	63	60	53		
								Extract	64	66	57	58	51	41	33	29		
4 XB4-**	1	423	2.8	2.8	4.5	18.7	*	Intake	76	75	71	70	69	60	57	53	36	155
								Supply	64	62	63	61	59	56	46	36		
								Discharge	74	73	70	73	70	68	63	56		
								Extract	67	63	55	57	54	45	37	30		
5 XB5-**	1	690	3.6	3.6	4.5	18.7	*	Intake	80	79	75	74	73	64	61	57	38	155
								Supply	68	66	67	65	63	60	50	40		
								Discharge	78	77	74	77	74	72	67	60		
								Extract	71	67	59	61	58	49	41	34		
6 S6-XB-**	1	850	6	6	6	25	*	Intake	82	86	80	68	67	64	57	51	47	212
								Supply	76	79	76	67	62	59	50	40		
								Discharge	85	86	80	74	72	68	61	54		
								Extract	77	80	73	64	59	55	47	44		

Units are supplied c/w with 2 No.G4 filters as standard. F5 & F7 filters are available as integrated options on supply.

Motor power and current loads are the total for both fans running together. Unit has a soft start function therefore the starting current is identical to the full load.

** Add relevant code for handling and heater type.

* For details on coils, codes and selection please refer to page 73.

Note: Size 6 - 1 phase = supply for fan, 3 phase = supply for electric heater battery.

DIMENSIONS AND CONFIGURATIONS

XBOXER Horizontal size S1-XB

DIMENSIONS (mm)

Code	A	B	C	D
S1-XB	1361	1000	340	250

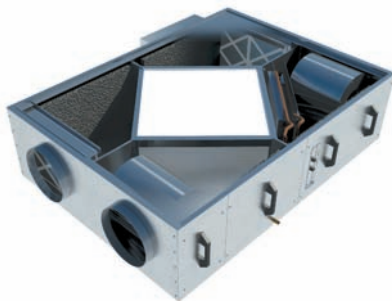
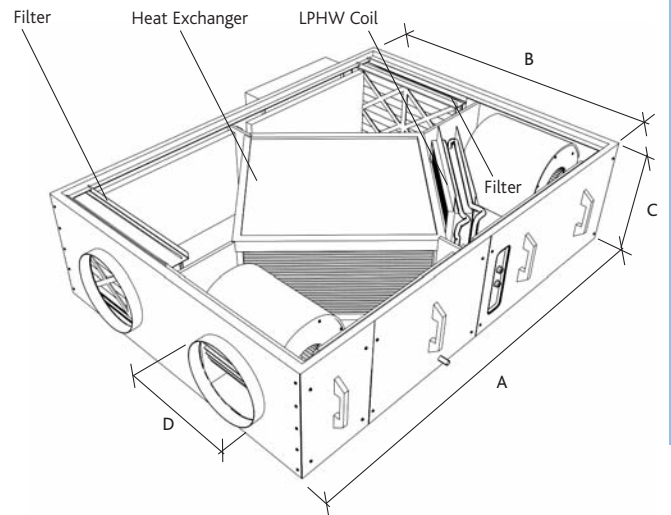

Model shown: S1-XB-LL (left hand with LPHW).

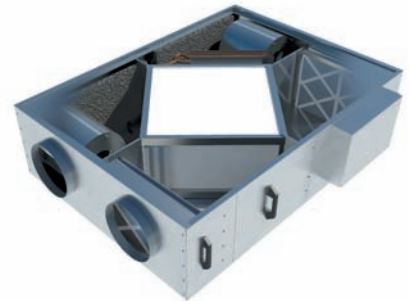

Model shown: S1-XB-RL (right hand with LPHW).

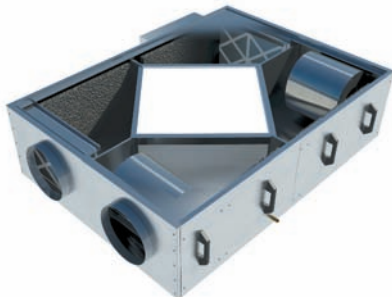

Model shown: S1-XB-LN (left hand with no heater).

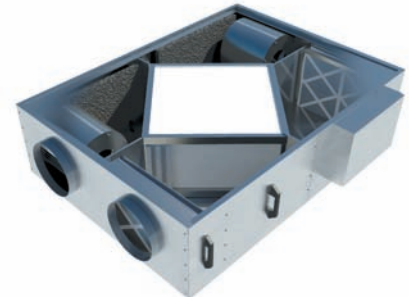

Model shown: S1-XB-RN (right hand with no heater).

AIR HANDLING UNITS (AHU'S)

XBOXER HEAT EXCHANGE

TECHNICAL INFORMATION

DIMENSIONS AND CONFIGURATIONS

XBOXER Horizontal sizes XB2, 3, 4, 5 and S6-XB

DIMENSIONS (mm)

Code	A	B	C	D
XB2	1700	1150	340	315
XB3	1700	1150	340	315
XB4	1700	1150	340	315
XB5	1700	1150	340	315
S6-XB	1700	1150	700	500

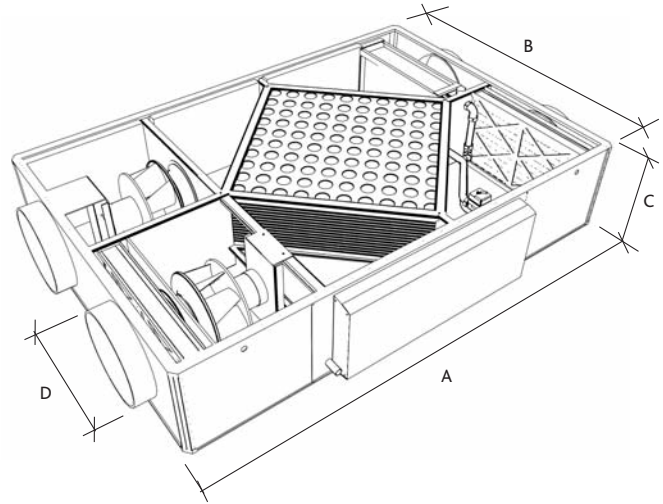

Model shown: XB2-5-LL (left hand with LPHW).

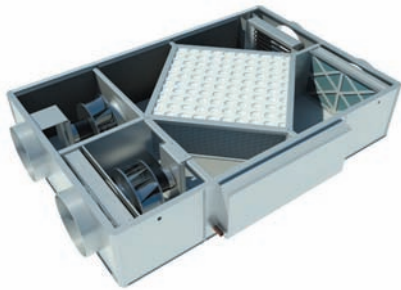

Model shown: XB2-5 and S6-XB-RE (right hand with electric heater).

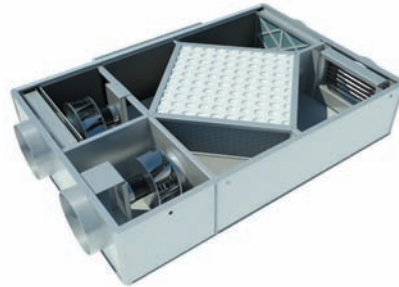

Model shown: XB2-5 and S6-XB-LE (left hand with electric heater).

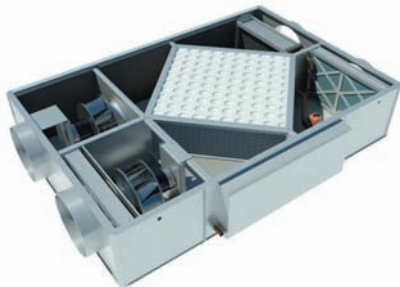

Model shown: XB2-5 and S6-XB-LL (left hand with LPHW).

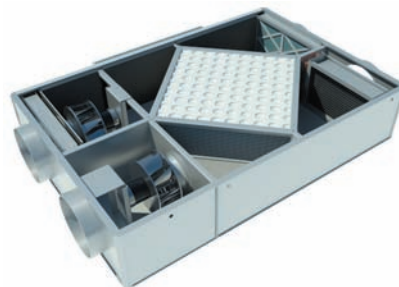

Model shown: XB2-5 and S6-XB-RL (right hand with LPHW).

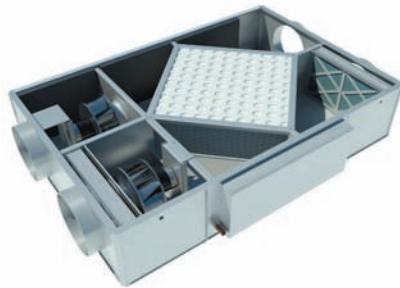

Model shown: XB2-5 and S6-XB-LN (left hand with no heater).

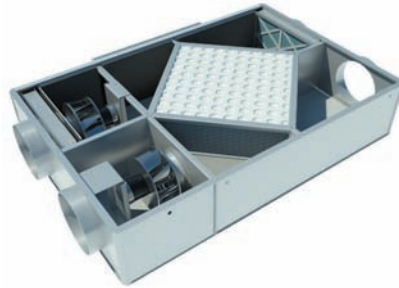

Model shown: XB2-5 and S6-XB-RN (right hand with no heater).

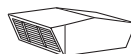

For weatherproof cowls refer to page 71

WEATHER PROTECTION FOR XBOXER HORIZONTAL UNIT

Sizes XB2 - 5 and XB6

- Weatherproof construction
- Can be retro fitted on site (Please contact Nuaire)
- Complete with bird/vermin mesh and internal airflow divider
- Available in 2 sizes

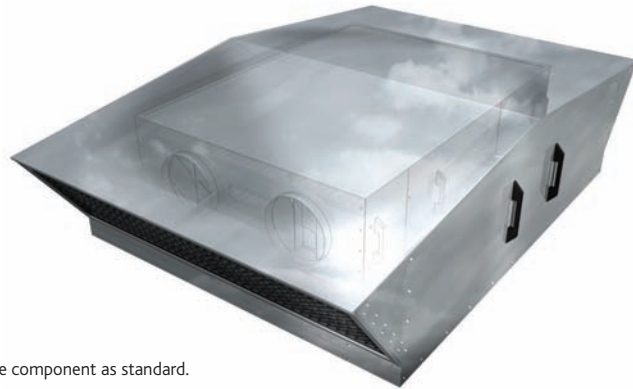

Note: The enclosure above is supplied as a separate component as standard.

DIMENSIONS (mm)

View from end

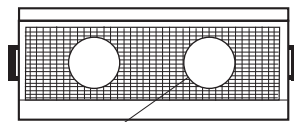

Vermin mesh guard (can be removed and cut for duct access).

View from side

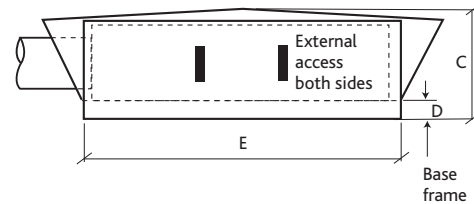

View from top

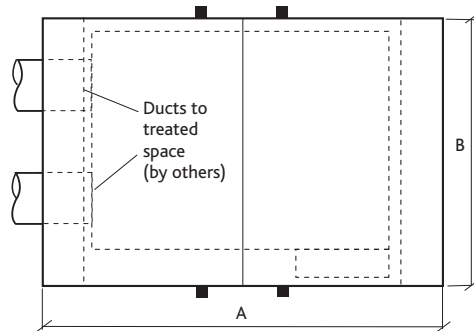

DIMENSIONS (mm)

Unit Code	Unit size	A	B	C	D	E	Weight (Kg)
SXB-WP	2 - 5	2400	1400	530	100	1800	65
SXB6-WP	6	2400	1400	880	100	1800	79

Code example for on-site fitting

SXB - WP

Code example for factory fitting

XB2 - LEWP

ACOUSTIC ENCLOSURE FOR XBOXER HORIZONTAL UNIT

Sizes XB2 - 5

The additional breakout reduction of a standard 25mm double skinned pentapost enclosure (close coupled to the unit inside) is as shown below.

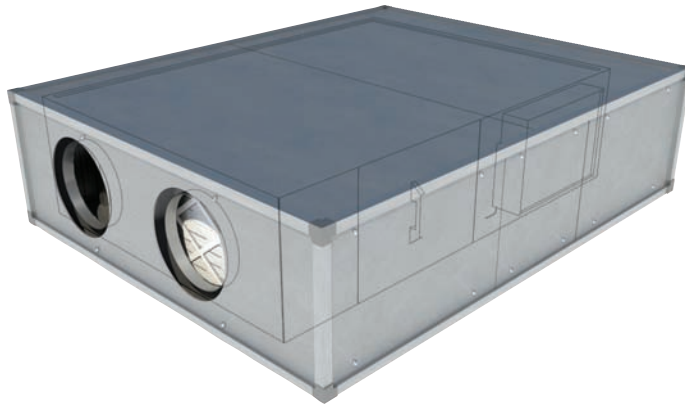

BREAKOUT REDUCTION

	Frequency (Hz)						
	125	250	500	1K	2K	4K	8K
Sound reduction index Db	8	14	21	23	24	23	19

Code example for factory fitting

XB2 - RL - AE

It is recommended the Acoustic Enclosure (see code example below) be ordered with the XBOXER unit and fitted at the factory.



XBOXER Size 1, 2, 3, 4 and 5

Air Volume Flow rate (m ³ /s)		0.4		0.3		0.2		0.1		Connection size								
Water on/off	Air On C	Heat Output (kW)	Air Off C	Water flow rate (l/s)	Water dp (kPa)	Heat Output (kW)	Air Off C	Water flow rate (l/s)	Water dp (kPa)		Heat Output (kW)	Air Off C	Water flow rate (l/s)	Water dp (kPa)				
82/71	-3	6.3	10	0.14	6.9	5.5	12	0.122	5.2	4.3	15	0.095	3.3	2.5	18	0.056	1.1	15 mm
	3	5.6	15	0.126	5.6	5.1	17	0.113	4.5	4	19	0.088	2.83	2.3	22	0.052	0.95	
	9	5	19	0.115	4.7	4.7	22	0.104	3.9	3.7	24	0.082	2.46	2.2	27	0.048	0.81	
	15	4.6	24	0.104	3.9	4.2	26	0.095	3.3	3.4	29	0.075	2.06	2	31	0.044	0.68	
80/60	-3	6.1	9.7	0.075	1.98	4.8	10	0.058	1.18	3.6	12	0.044	0.71	2.15	15	0.026	0.24	15 mm
	3	4.7	13	0.058	1.18	4.3	15	0.052	0.94	3.3	17	0.041	0.61	2	19	0.024	0.20	
	9	4.2	18	0.052	0.95	3.8	19	0.047	0.77	3	21	0.037	0.50	1.8	24	0.022	0.17	
	15	3.7	23	0.046	0.74	3.4	24	0.042	0.62	2.7	26	0.033	0.40	1.6	28	0.019	0.13	
60/40	-3	4.4	6.2	0.054	1.03	4	8	0.048	0.80	3.1	10	0.037	0.50	1.6	10	0.019	0.13	15 mm
	3	2.9	9	0.035	0.43	2.6	10	0.032	0.36	2	11	0.025	0.23	1.1	12	0.014	0.07	
	9	2.4	14	0.029	0.30	2.2	15	0.026	0.24	1.7	16	0.02	0.15	1	17	0.013	0.06	
	15	1.9	19	0.023	0.19	1.7	20	0.021	0.15	1.3	20	0.016	0.09	0.9	22	0.012	0.05	

XBOXER Size 1, 2, 3, 4 and 5

Air Volume Flow rate (m ³ /s)		0.4		0.3		0.2		0.1		Connection size								
Water on/off	Air On C	Heat Output (kW)	Air Off C	Water flow rate (l/s)	Water dp (kPa)	Heat Output (kW)	Air Off C	Water flow rate (l/s)	Water dp (kPa)		Heat Output (kW)	Air Off C	Water flow rate (l/s)	Water dp (kPa)				
82/71	-3	14	26	0.32	14.5	12.5	31	0.278	11.5	9.5	36	0.212	7.1	5.4	41	0.121	2.74	15 mm
	3	13	30	0.292	12.5	11.5	35	0.257	10	8.8	39	0.196	6.3	5	44	0.112	2.40	
	9	12	33	0.267	10.7	10.5	38	0.236	8.6	8	42	0.18	5.4	4.6	47	0.103	2.08	
	15	10.8	37	0.242	9	9.6	41	0.214	7.3	7.4	45	0.16	4.6	4.2	50	0.094	1.78	
80/60	-3	12	22	0.149	3.9	10.7	26	0.13	3.2	8	30	0.1	1.98	4.7	35	0.057	0.76	15 mm
	3	11	26	0.135	3.3	9.7	30	0.119	2.72	7.5	33	0.091	1.69	4.3	38	0.052	0.65	
	9	9.9	29	0.12	2.74	8.8	33	0.107	2.27	6.7	36	0.082	1.41	3.9	41	0.047	0.55	
	15	8.8	33	0.11	2.36	7.8	36	0.095	1.85	6	39	0.073	1.16	3.5	43	0.042	0.45	
60/40	-3	8	13	0.097	1.91	7	16	0.085	1.53	5.3	19	0.065	0.95	3	21	0.036	0.35	15 mm
	3	6.9	17	0.083	1.46	6	20	0.073	1.18	4.6	22	0.056	0.74	2.5	24	0.031	0.27	
	9	5.7	21	0.069	1.07	5	23	0.061	0.87	3.8	24	0.046	0.53	2	26	0.025	0.19	
	15	4.5	24	0.054	0.70	4	26	0.048	0.58	3	27	0.036	0.35	1.8	28	0.023	0.16	

XBOXER Size 6

Air Volume Flow rate (m ³ /s)		0.6		0.4		0.2		Connection size										
Water on/off	Air On C	Heat Output (kW)	Air Off C	Water flow rate (l/s)	Water dp (kPa)	Heat Output (kW)	Air Off C		Water flow rate (l/s)	Water dp (kPa)	Heat Output (kW)	Air Off C	Water flow rate (l/s)	Water dp (kPa)				
82/71	-3	11	12	0.244	5.2	8.6	15	0.19	3.3	5	18	0.112	1.1					22 mm
	3	10.2	17	0.226	4.5	8	19	0.176	2.83	4.6	22	0.104	0.95					
	9	9.4	22	0.208	3.9	7.4	24	0.164	2.46	4.4	27	0.096	0.81					
	15	8.4	26	0.19	3.3	6.8	29	0.15	2.06	4	31	0.088	0.68					
80/60	-3	9.6	10	0.116	1.18	7.2	12	0.088	0.71	4.3	15	0.052	0.24					15 mm
	3	8.6	15	0.104	0.94	6.6	17	0.082	0.61	4	19	0.048	0.20					
	9	7.6	19	0.094	0.77	6	21	0.074	0.50	3.6	24	0.044	0.17					
	15	6.8	24	0.084	0.62	5.4	26	0.066	0.40	3.2	28	0.038	0.13					
60/40	-3	8	8	0.096	0.80	6.2	10	0.074	0.50	3.2	10	0.038	0.13					15 mm
	3	5.2	10	0.064	0.36	4	11	0.05	0.23	2.2	12	0.028	0.07					
	9	4.4	15	0.052	0.24	3.4	16	0.04	0.15	2	17	0.026	0.06					
	15	3.4	20	0.042	0.15	2.6	20	0.032	0.09	1.8	22	0.024	0.05					

XBOXER Size 6

Air Volume Flow rate (m ³ /s)		0.6		0.4		0.2		Connection size										
Water on/off	Air On C	Heat Output (kW)	Air Off C	Water flow rate (l/s)	Water dp (kPa)	Heat Output (kW)	Air Off C		Water flow rate (l/s)	Water dp (kPa)	Heat Output (kW)	Air Off C	Water flow rate (l/s)	Water dp (kPa)				
82/71	-3	25	31	0.556	11.5	19	36	0.424	7.1	10.8	41	0.242	2.74					22 mm
	3	11.5	35	0.514	10	17.6	39	0.392	6.3	10	44	0.224	2.40					
	9	21	38	0.472	8.6	16	42	0.36	5.4	9.2	47	0.206	2.08					
	15	19.2	41	0.428	7.3	14.8	45	0.32	4.6	8.4	50	0.188	1.78					
80/60	-3	21.4	26	0.26	3.2	16	30	0.2	1.98	9.4	35	0.114	0.76					15 mm
	3	19.4	30	0.238	2.72	15	33	0.182	1.69	8.6	38	0.104	0.65					
	9	17.6	33	0.214	2.27	13.4	36	0.164	1.41	7.8	41	0.094	0.55					
	15	15.6	36	0.19	1.85	12	39	0.146	1.16	7	43	0.084	0.45					
60/40	-3	14	16	0.17	1.53	10.6	19	0.13	0.95	6	21	0.072	0.35					15 mm
	3	12	20	0.146	1.18	9.2	22	0.112	0.74	5	24	0.062	0.27					
	9	10	23	0.122	0.87	7.6	24	0.092	0.53	4	26	0.05	0.19					
	15	8	26	0.096	0.58	6	27	0.072	0.35	3.6	28	0.046	0.16					

AIR HANDLING UNITS (AHU'S)

XBOXER HEAT EXCHANGE

TECHNICAL INFORMATION

HEAT RECOVERY PERFORMANCE

To determine the temperature of the supply air - after the heat exchanger module (but before the heater if fitted), refer to the following table.

When selecting heater batteries, use this temperature as the "Air On" temperature in the coil selection tables.

Heat Exchanger Temperature Ratio (%) ("efficiency")	Intake Air Temperature (deg C) (External)	(ROOM) Extract Air Temperature (deg C)					
		5	10	15	20	25	30
		Supply Air Temperature (deg C)					
55	-5	1	3	6	9	12	14
	0	3	6	8	11	14	17
	5	5	8	11	13	16	19
	10	7	10	13	16	18	21
	15	10	12	15	18	21	23
60	-5	1	4	7	10	13	16
	0	3	6	9	12	15	18
	5	5	8	11	14	17	20
	10	7	10	13	16	19	22
	15	9	12	15	18	21	24
65	-5	2	5	8	11	15	18
	0	3	7	10	13	16	20
	5	5	8	12	15	18	21
	10	7	10	13	17	20	23
	15	9	12	15	18	22	25
70	-5	2	6	9	13	16	20
	0	4	7	11	14	18	21
	5	5	9	12	16	19	23
	10	7	10	14	17	21	24
	15	8	12	15	19	22	26
75	-5	3	6	10	14	18	21
	0	4	8	11	15	19	23
	5	5	9	13	16	20	24
	10	6	10	14	18	21	25
	15	8	11	15	19	23	26
80	-5	3	7	11	15	19	23
	0	4	8	12	16	20	24
	5	5	9	13	17	21	25
	10	6	10	14	18	22	26
	15	7	11	15	19	23	27
85	-5	4	8	12	16	21	25
	0	4	9	13	17	21	26
	5	5	9	14	18	22	26
	10	6	10	14	19	23	27
	15	7	11	15	19	24	28
90	-5	4	9	13	18	22	27
	0	5	9	14	18	23	27
	5	5	10	14	19	23	28
	10	6	10	15	19	24	28
	15	6	11	15	20	24	29

Other conditions may be calculated using the equation:

$$\eta_t = \text{Thermal efficiency} = \frac{t_{\text{supply}} - t_{\text{intake}}}{(t_{\text{extract}} - t_{\text{intake}})}$$

This table and equation assume that the supply and extract mass flow rates are equal.

Note: for specific fan power ratings contact Nuaire for details.



HOW MUCH ENERGY DOES THE EXCHANGER SAVE?

In a building ventilation system that does not have a heat recovery facility, the air used for ventilation enters the building at the external ambient temperature, and is expelled from the building at approximately room temperature.

This increase in temperature may be caused directly by heaters intended to raise the air temperature to a suitable value for supply to occupied rooms, or indirectly by heat transfer from the buildings internal surfaces and existing air content.

This "ventilation heat loss" can be quantified as:

$$\text{Air Mass Flow rate (kg/s)} \times \text{Temperature difference (deg C)} \times \text{Specific Heat Capacity of air (kJ/kg deg C)}$$

(Air volume flow rate (m³/s) x Air density (kg/m³)
 x Temperature difference (deg C) [Ta internal – Ta external]
 x Specific Heat Capacity of air (kJ/kg deg C)

(Approx = 1)

Using some typical (heating season) values, the power required to heat unit air flow, and which is then lost is:

$$= 1\text{m}^3/\text{s} \times 1.2\text{ kg/m}^3 \times (22-6)\text{ deg C} \times 1$$

$$= 19.2\text{ kW}$$

Heat recovery systems reduce this heat loss by transferring the heat contained in the extracted air to the supply air.

A system with a heat exchange efficiency of 70% will recover 70% of the energy supplied therefore reducing the power required.

There is of course an energy penalty in terms of the additional pressure loss due to the heat exchanger element itself, and this needs to be minimized by optimal selection of the system fans, motors and control systems. Generally, it can be demonstrated that the additional system losses are small compared to the reduction in heating load.

ELECTRIC HEATING

To find the final supply air temperature when an electric heater is required, use the following table:

Air Volume Flow rate m ³ /s	Intake Air Temperature (deg C)	Electric heater kW											
		2	3	6	9	12	15	18	21	24	27	54	
		Supply Air Temperature (deg C)											
0.1	-5	12	20										
	0	17	25										
	5	22	30										
	10	27	35										
	15	32											
0.2	-5		8	20	33								
	0	8	13	25	38								
	5	13	18	30									
	10	18	23	35									
	15	23	28										
0.4	-5			8	14	20	26	33					
	0		6	13	19	25	31	38					
	5	9	11	18	24	30	36						
	10	14	16	23	29	35							
	15	19	21	28	34								
0.6	-5			8	8	12	16	20	24	28	33		
	0			13	13	17	21	25	29	33	38		
	5	8	9	13	18	22	26	30	34	38			
	10	13	14	18	23	27	31	35	39				
	15	18	19	23	28	32	36						
0.8	-5			6	9	8	11	14	17	20	23		
	0			11	13	13	16	19	22	25	28		
	5	7	8	11	14	18	21	24	27	30	33		
	10	12	13	16	19	23	26	29	32	35	38		
	15	17	18	21	24	28	31	34	37				
1	-5			5	8	5	8	10	13	15	18	23	40
	0			10	13	10	13	15	18	20	23	28	
	5	7	8	10	13	15	18	20	23	25	28	33	
	10	12	13	15	18	20	23	25	28	30	33	38	
	15	17	18	20	23	25	28	30	33	35	38		
1.5	-5				5	7	8	5	7	8	10	15	25
	0				10	12	13	10	12	13	15	20	30
	5	6	7	8	10	12	13	15	17	18	20	25	35
	10	11	12	13	15	17	18	20	22	23	25	30	40
	15	16	17	18	20	22	23	25	27	28	30		
2	-5					5	6	8	9	5	6	18	
	0					10	11	13	14	10	11	23	
	5	6	6	8	9	10	11	13	14	15	16	28	
	10	11	11	13	14	15	16	18	19	20	21	33	
	15	16	16	18	19	20	21	23	24	25	26	38	
3	-5							5	6	7	8	10	
	0							10	11	12	13	15	
	5	6	6	7	8	8	9	10	11	12	13	20	
	10	11	11	12	13	13	14	15	16	17	18	25	
	15	16	16	17	18	18	19	20	21	22	23	30	

WIRING FOR XB2-5 & S6-XB-R/L E EXTRACT/SUPPLY

S1-XB & S6-XB-R/L N EXTRACT/SUPPLY

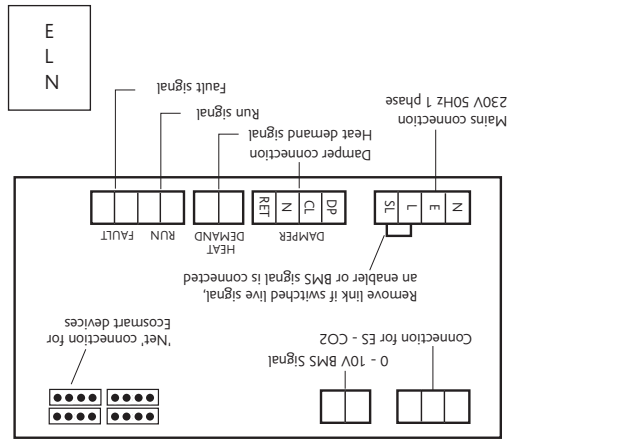
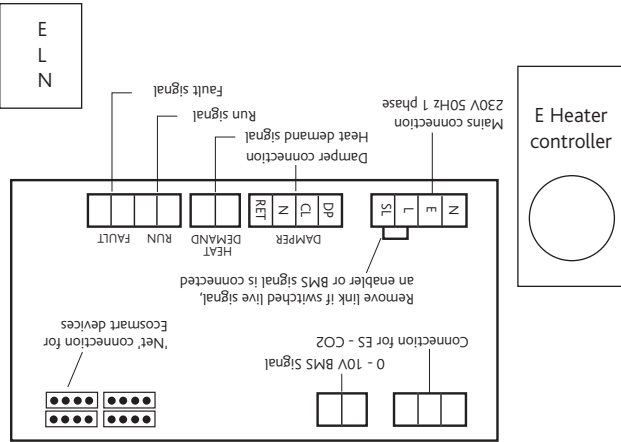
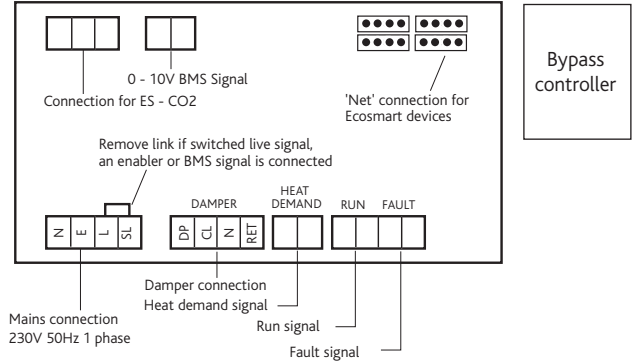
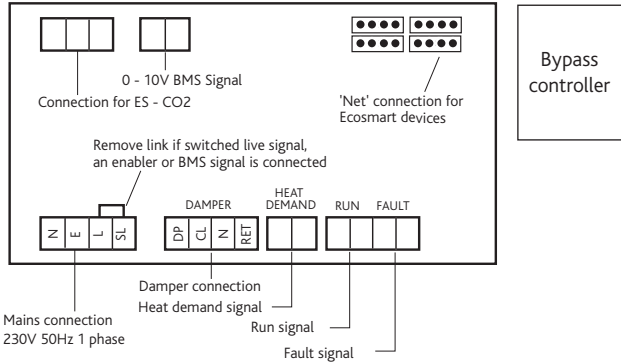

WIRING FOR S1-XB, XB2-5 & S6-XB-R/L L EXTRACT/SUPPLY

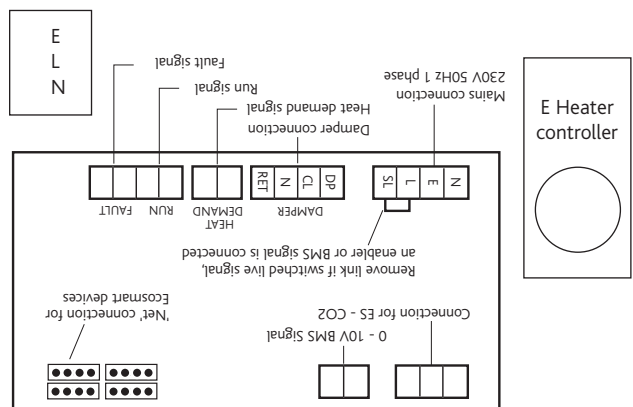
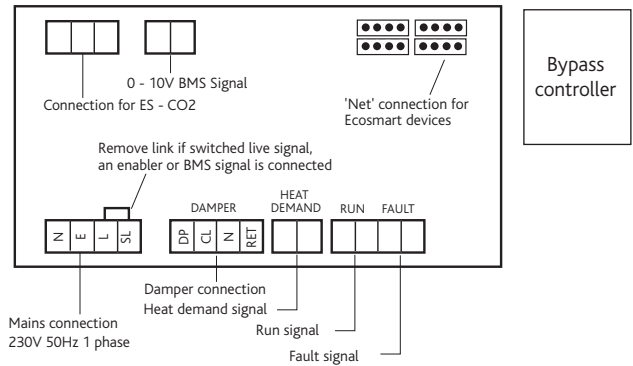

XB2-5 WITH ECOSMART FAN ONLY CONTROL

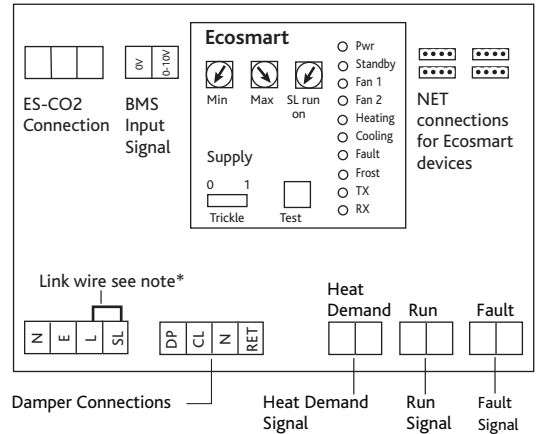
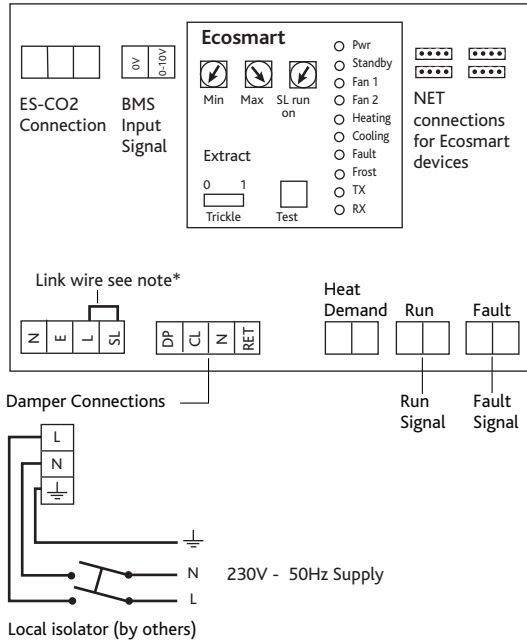

All inter-connections between circuit boards, blowers and sensors are made at the factory. This diagram only shows the essential field wiring points for clarity.

*Remove link wire if switched live signal, an enabler or BMS signal is connected.

XB2-5 WITH ECOSMART CONTROL AND ELECTRIC HEATER

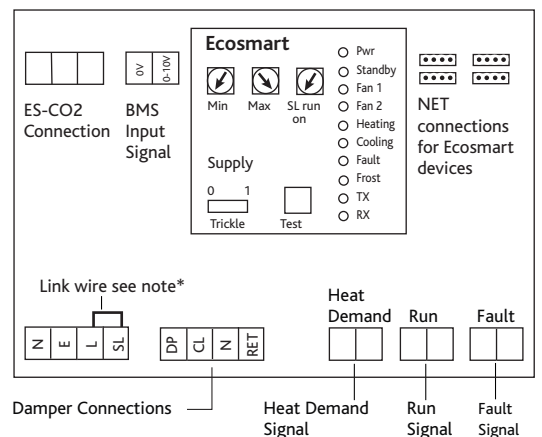
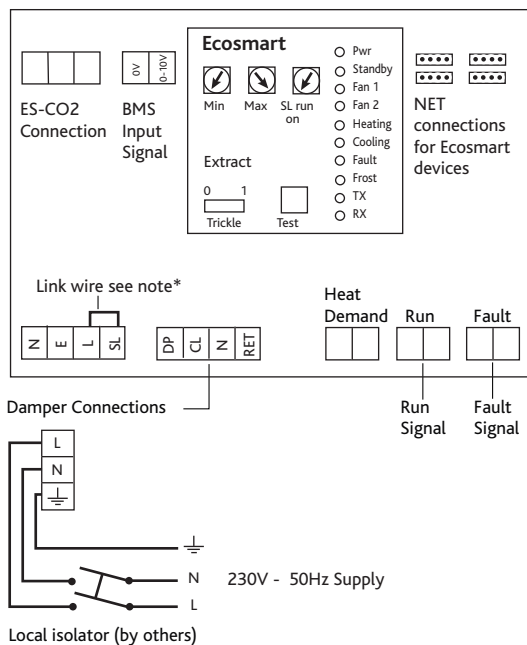

All inter-connections between circuit boards, blowers and sensors are made at the factory. This diagram only shows the essential field wiring points for clarity.

*Remove link wire if switched live signal, an enabler or BMS signal is connected.

XB2-5 WITH ECOSMART FAN AND LPHW COIL CONTROL

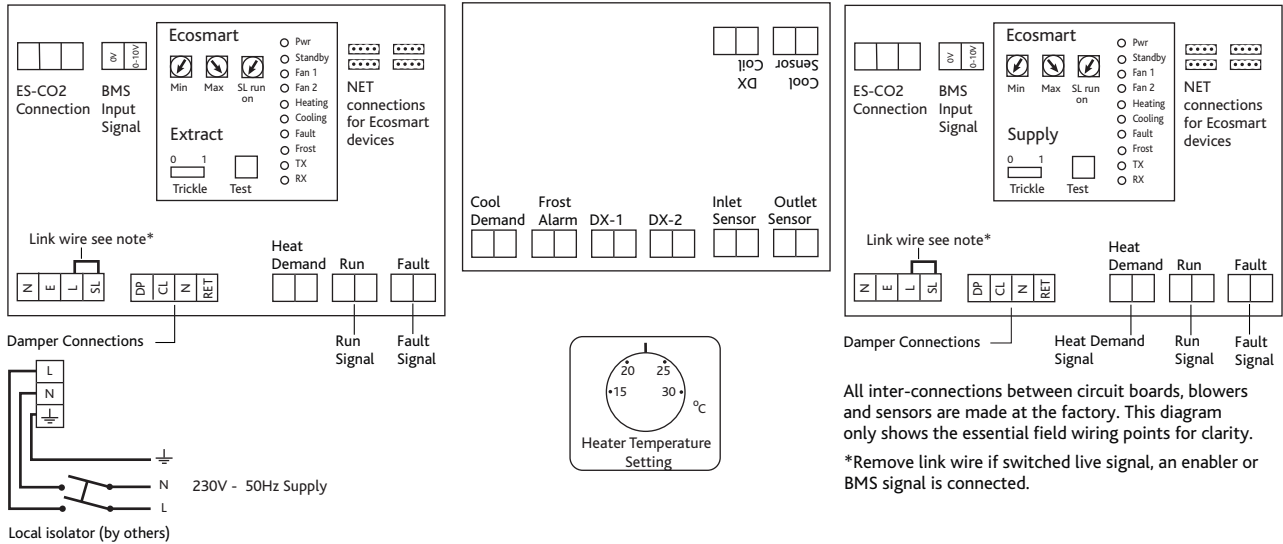

All inter-connections between circuit boards, blowers and sensors are made at the factory. This diagram only shows the essential field wiring points for clarity.
 *Remove link wire if switched live signal, an enabler or BMS signal is connected.

WIRING - FOR UNITS SUPPLIED WITHOUT ECOSMART CONTROL

The wiring illustrations below are for the fans, bypass damper and electric heater for units without control. All wiring is terminated in junction boxes fitted to the specified side of the unit.

It is the installer's responsibility to select and fit the appropriate control equipment to produce the desired output.

Note that any heating/cooling coils fitted are supplied without control valve and actuator.

ELECTRICAL DETAILS

Unit size	Fan motor ratings		Electric heater ratings (if fitted)	
	flc	sc	kW	flc
XB2	2 x 0.75A	2 x 3A	4.5kW	18.7A
XB3	2 x 0.75A	2 x 3A	4.5kW	18.7A
XB4	2 x 1.2A	2 x 4.8A	4.5kW	18.7A
XB5	2 x 1.2A	2 x 4.8A	4.5kW	18.7A

Bypass damper rated at 3W, 13mA for all unit sizes.

(Unit sizes XB2-5) Fan wiring. Two per unit and one per blower.

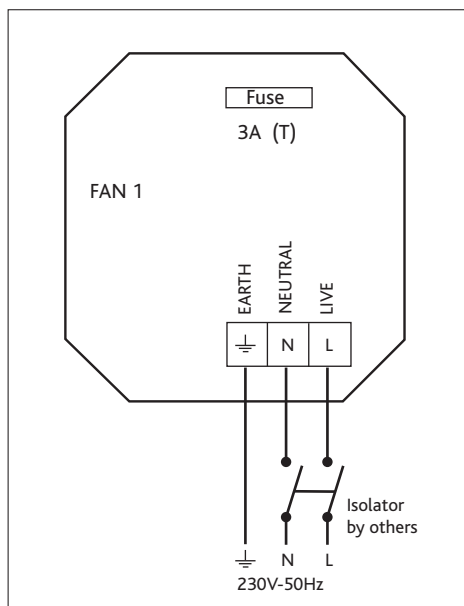

(Unit sizes XB2-5) with electric heater, heat exchanger bypass damper and electric heater wiring.

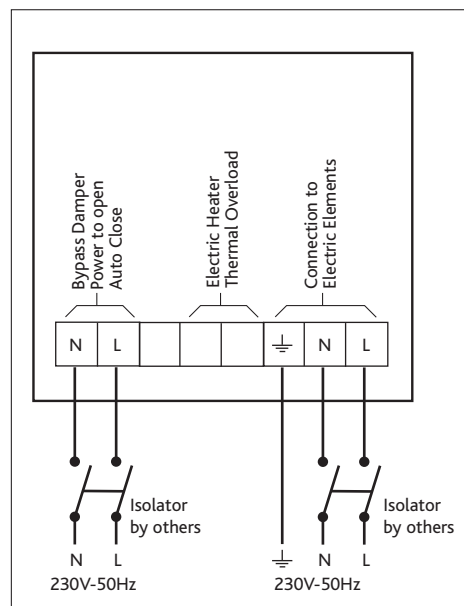

(Unit sizes XB2-5) Fan only or with LPHW coil, heat exchanger bypass damper wiring.

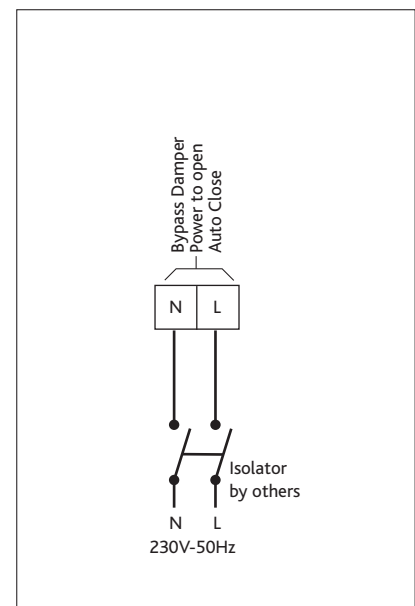

CONSULTANTS SPECIFICATION

XBOXER TWINFAN UNITS

OPERATION

The supply and extract ventilation unit shall be as indicated on the drawings and shall be in accordance with the particular fan schedule in the specification.

Supply air to the room shall be pre-heated by the extract air via the integrated heat exchanger matrix. Where fitted an integrated heater battery shall raise the temperature of the supply air to the design room temperature after the air has passed through the heat exchanger.

The ventilation unit shall automatically vary the ventilation rate, as it receives signals from one of the optional interconnected sensors. When signals are received, the fan shall either vary its speed proportionally or on a trickle and boost principle. The unit shall have the facility to commission the supply and extract fans individually via inbuilt minimum and maximum speed adjustment, the fans themselves shall have infinitely variable speed control.

XBOXER TWINFANS - UNIT SPECIFICATION

Unit codes XB shall be manufactured in aluminium alloy with 25mm double skinned infill panels and extruded aluminium frame. Unit codes XBV and H shall be manufactured from Aluzinc with 25mm infill panels, giving extremely low noise levels. It shall be come c/w a high efficiency heat exchanger block, supply and extract filters, automatic summer bypass, integral minimum and maximum infinitely variable speed controls, run on timer and fascia mounted failure indication. The unit shall have low energy, high efficiency a.c. fan/motor assemblies with sealed for life bearings. Impellers shall be high efficiency mixed flow or centrifugal type.

The unit shall have a robust plastic/aluminium heat exchanger matrix with a thermal efficiency of up to 55 - 70% that shall be protected by G4* grade pleated filters on supply and extract. It shall come complete with condensate drip tray and 22mm drain connection (XB2-5 has a 15mm drain connection). Alternatively a condensate pump shall be provided if specified.

The unit shall be constructed with removable panels allowing full maintenance access from the side (access handing to be confirmed in product code and verified on site prior to order). The removable panels shall provide access to the following:

- Supply or extract fan.
- Supply & extract filter.
- Heat exchanger block.
- Heater battery temperature adjustment (where included).
- LPHW Heater pipe connections. (where included).
- Speed control commissioning adjustment (min & max).
- Electrical connection terminal blocks.
- Units shall be the as manufactured by Nuair.
- 2 fans incorporate auto change over in the event of one fan failing.

* Other filter specifications including high capacity filters & grade F7 available as integrated options.

XBOXER TWINFANS - ECOSMART CONTROLS

All versions shall incorporate the following functions integrally mounted, pre-wired and factory fitted by the manufacturer: -

- Integral infinitely variable speed control on supply and extract.
- Integral background ventilation control/set point.
- Integral boost ventilation control/set point.
- Integral BMS interfaces – summer/winter switching, heating control**, 0-10V speed adjustment.
- Integral run on timer.
- Volt free failure indication (direct from individual fan).
- Integral S/L terminal for boost trigger from remote switch, e.g. lightswitch.
- Integral air off coil temperature adjustment**
- Multiple IDC sockets for interconnection of up to 6 Ecosmart sensors, controllers or fans using pre-plugged 4-core low voltage cable.
- Volt free frost alarm/heat demand interface**
- Frost protection/hold off stat**
- The unit shall be controlled by the ECOSMART control devices (enablers & sensors) as detailed in the schedule on the drawings.
- 2 fans incorporate auto change over in the event of one fan failing.
- LPHW pipework connections c/w diverting valve and actuator.**

** Versions incorporating heater sections.

INVERTER DRIVES

Sizes 2 - 5 have AC control, size 6 has EC control.

NO CONTROL OPTION (SIZES 7-10 XBH + XBV)

Unit provides side mounting of termination box to connect supply and extract fan motor wiring (terminal boxes) for interface to custom built control panels. For this option, no sensors are fitted to the unit, but with plate heat exchanger units the bypass damper actuator is included.

COIL TYPES AND CONTROLS

The control for the coils shall be fully integrated and shall maintain a constant off coil temperature. The system shall have frost protection which shall, at temperatures below 4 degrees C, fully open the 3 or 4-port valve and only start the fan when the temperature at the filter has risen above the designated set point.

LOW PRESSURE HOT WATER

The Low Pressure Hot Water heating coil shall be factory fitted with a 3 or 4 port valve, drain cocks and air vents. The actuator controlling the 3 or 4 port valve shall be controlled via the on-board PCB by the off coil temperature sensor. All components pre-piped, assembled and tested by the manufacturers.

ELECTRIC

The Electric Heater Battery shall be factory fitted and pre-wired to an integral closed loop thyristor control. When the unit is switched off, the fan shall continue to run to dissipate heat from the electric heater battery before stopping.

The Ecosmart control unit shall have a 5 year warranty.

The manufacturer's recommendations should be observed at all times.

The unit shall be the XBOXER and shall be manufactured by Nuair.

XBOXER THERMAL WHEEL HEAT RECOVERY UNITS

HIGH EFFICIENCY ROTARY WHEEL - HELPING TO SAVE ENERGY AND
REDUCE CARBON EMISSIONS.



BENEFITS

HIGH EFFICIENCY

Up to 85% efficient wheel combined with high efficiency motors and backward curved impellers.

OPTIONAL ENERGY EFFICIENT CONTROLS

Full Ecosmart control compatibility provides a simple 'plug & go' control solution with BMS interface and trickle and boost as standard.

DUAL FANS/MOTORS

Lower profile units with more uniform air distribution over heater batteries/ exchangers.

NO CONTROL OPTION

For control integration by others.

SPACE SAVING SOLUTION

Stacked configuration reduces overall space requirements and is ideal for plant room, or roof top applications.

QUIETEST SOLUTION

The range has 25mm double skinned infill panels, helping to keep breakout noise to the lowest possible levels.

HIGH PERFORMANCE RANGE

3 case options available as standard with performance up to 2m³/s. Contact Nuair for other duties or refer to AHU catalogue.

QUICK COMMISSIONING*

Integrated supply and extract fan control allows precise system duty adjustment and can be quickly and accurately set *Ecosmart models only.

EASY MAINTENANCE

The unit provides access to both right and left sides. It is recommended that clear space left be the full width of the stacked unit.

INTEGRATED REGENERATION CONTROL

Operates automatically by shutting the wheel rotation down.

WEATHERPROOF DETAIL

Can be factory fitted or fitted on site, please refer to page 88 for details.

FILTER OPTIONS

G4 fitted as standard. Higher grade integrated filters available or as a duct mounted ancillary. Contact Nuair for details.

CONSTANT PRESSURE CONTROL AVAILABLE

For further information contact Nuair.

DX COIL & CHILLED WATER COOLING OPTIONS

Please refer to pages 00 to 00.

FLEXIBLE RANGE

Models 1, 2 and 3 include LPHW, no heater and electric heater options. For further details please refer to AHU catalogue.

ANCILLARIES

A range of ancillaries are available including manometers, bulkhead lights, view ports, drain trays and traps.

For further details please contact Nuair.

WARRANTY

Models with Ecosmart control have a 5 year warranty.

No control models have a 2 year warranty*.

*Contact Nuair for further details.

Note: Thermal wheels have specific maintenance requirements.

Refer to installation and maintenance manual.

FEATURES INCLUDE:



With LPHW.



Constant Pressure control option.



Pressure independent balancing control (T1 & T2 LPHW models only).



Filter options.



Frost coil option. (See page 87).

AIR HANDLING UNITS (AHU'S)

XBOXER THERMAL WHEEL

TECHNICAL INFORMATION

PERFORMANCE - XBOXER THERMAL WHEEL

Xboxer Thermal wheel sizes 1, 2 and 3

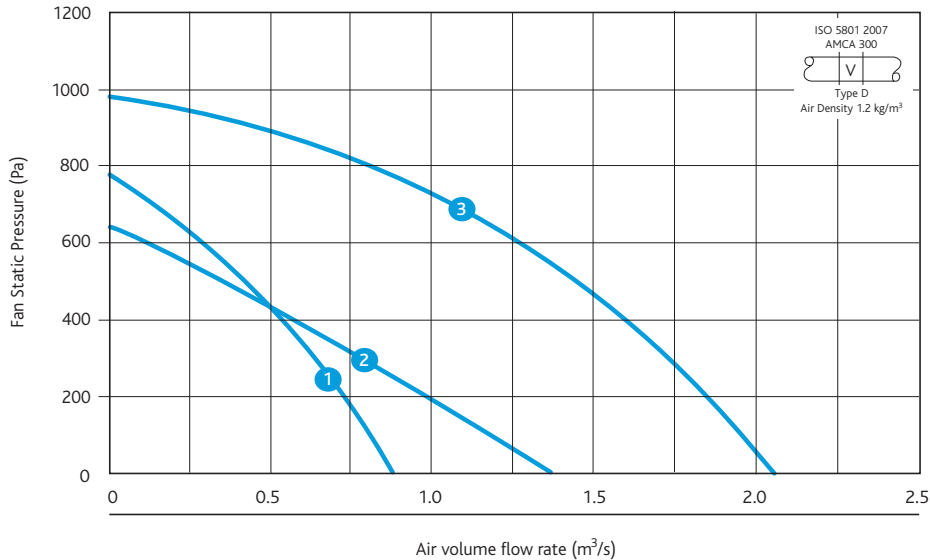

Casing



Code description (Example)

T1NC - TWB - LL 2 WP

1 2 3 4 5 6 7

- 1. = Type/Curve Ref.
- 2. = Ecosmart control as standard
NC = No control
- 3. = Thermal wheel box
- 4. = Component layout
L = Left hand
R = Right hand
(Handings in direction of supply air)
- 5. = Type of heater
L = LPHW, N = No heater, E = Electric
- 6. = 2 row coil
- 7. = Optional Weather Roof

PERFORMANCE - XBOXER THERMAL WHEEL

ELECTRICAL, SOUND & WEIGHT

Curve	Code	Phase	Speed (RPM)	Motor power (kW)	Start current (amps)	Full load current (amps)	LPHW Heater (kW)		Induct Sound Power Levels dB re 1pW								Breakout dBA @3m	Weight Kg***
									63	125	250	500	1K	2K	4K	8K		
1	T1-TWB-**	1	1710	1.8	11.6	11.6	*	Intake	75	74	76	72	73	71	66	69	45	395
								Supply	79	79	81	78	79	77	73	66		
								Discharge	79	79	81	78	79	77	73	66		
								Extract	75	74	76	72	73	71	66	69		
								Breakout	72	68	71	61	57	55	56	50		
2	T2-TWB-**	3	2140	2.1	3.5	3.5	*	Intake	84	84	78	71	69	65	57	60	46	395
								Supply	88	89	83	77	75	71	64	57		
								Discharge	88	89	83	77	75	71	64	57		
								Extract	84	84	78	71	69	65	57	60		
								Breakout	81	78	73	60	53	49	47	41		
3	T3-TWB-**	3	2412	0.8	2.7	2.7	*	Intake	60	69	72	72	66	65	60	69	47	847
								Supply	69	78	82	82	82	80	77	66		
								Discharge	68	75	78	79	74	73	69	66		
								Extract	64	73	78	76	77	74	68	69		
								Breakout	64	73	78	76	77	74	68	69		

Units are supplied c/w with 2 No. G4 filters as standard. (F5 & F7 filters are available as integrated options on supply).

Motor power and current loads are the total for both fans running together. Ecosmart models have a soft start function therefore the starting current is identical to the full load.

** Add relevant code for heater type.

* For details on coils, codes refer to page 87.

***Weights of units are for guidance and include control and no weather roof.

DIMENSIONS AND CONFIGURATIONS

Xboxer Thermal wheel sizes 1, 2 and 3

DIMENSIONS (mm)

Code	A	B	C	Duct size D X E
T1-TWB	1470	1070	1163	949 X 494
T2-TWB	1470	1070	1163	949 X 494
T3-TWB	2000	1200	1676	1440 X 740

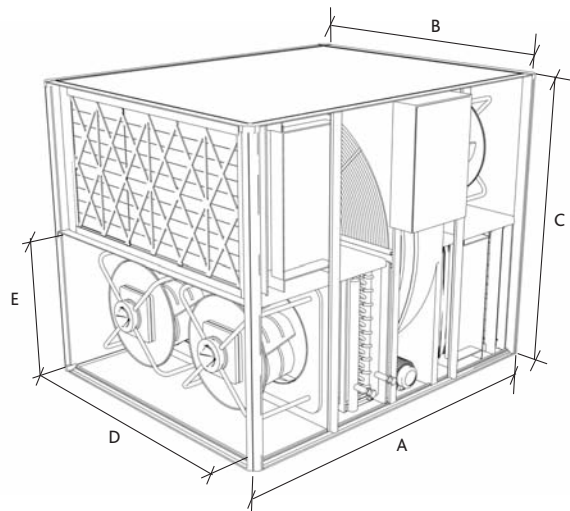

Model shown: T1-3NC-TWB-L (LPHW). No Ecosmart control.



Model shown: T1-3-TWB-L (LPHW). Includes Ecosmart control.

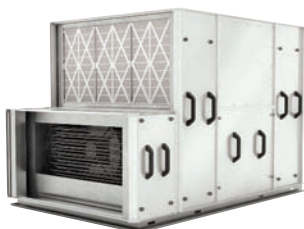

Model shown: T1-3NC-TWB-E (Electric heater). No Ecosmart control.



Model shown: T1-3-TWB-E (Electric heater). Includes Ecosmart control.

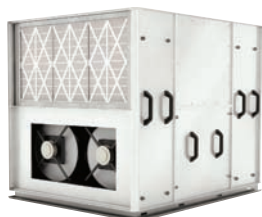

Model shown: T1-3NC-TWB-N (No heater). No Ecosmart control.



Model shown: T1-3-TWB-N (No heater). Includes Ecosmart control.



Model shown: T1-3NC-TWB-DX (With DX coil). No Ecosmart control.



Model shown: T1-3-TWB-DX (With DX coil). Includes Ecosmart control.

Note: Control box is integral.

AIR HANDLING UNITS (AHU'S)

XBOXER COIL PERFORMANCE

TECHNICAL INFORMATION

COOLING COIL AND CHILLED WATER PERFORMANCE

Size T1

Max Air Volume Flow Rate (m³/s)		0.722				18 Pa		0.36		26 Pa	
CWater Flow and Return Temp. (C)		Cooling Output kW total / sensible	Air Off Condition db (deg C) / Rh (%)	Water flow rate l/s	Water dp kPa	Cooling Output kW total / sensible	Air Off Condition db (deg C) / Rh (%)	Water flow rate l/s	Water dp kPa		
6 / 12	Entering Air Conditions db (deg C) /Rh (%)										
	25 / 50	9.5 / 7*	17 / 72.5	0.38	16.3	4.9 / 3.5**	17 / 72	0.193	10.6		
		Connection size		3/4" / 22mm		Connection size		3/4" / 22mm			

Size T2

Max Air Volume Flow Rate (m³/s)		1.1				0.75			
CWater Flow and Return Temp. (C)		Cooling Output kW total / sensible	Air Off Condition db (deg C) / Rh (%)	Water flow rate l/s	Water dp kPa	Cooling Output kW total / sensible	Air Off Condition db (deg C) / Rh (%)	Water flow rate l/s	Water dp kPa
6 / 12	Entering Air Conditions db (deg C) /Rh (%)								
	25 / 50	13.6 / 9.8	17.61 / 70.3	0.541	20.3	10.1 / 7.3	17.02 / 72.2	0.399	12.1
		Connection size		3/4" / 22mm		Connection size		3/4" / 22mm	

Size T3

Max Air Volume Flow Rate (m³/s)		1.8				0.9			
CWater Flow and Return Temp. (C)		Cooling Output kW total / sensible	Air Off Condition db (deg C) / Rh (%)	Water flow rate l/s	Water dp kPa	Cooling Output kW total / sensible	Air Off Condition db (deg C) / Rh (%)	Water flow rate l/s	Water dp kPa
6 / 12	Entering Air Conditions db (deg C) /Rh (%)								
	25 / 50	23 / 17	17 / 73	0.93	12	12.1 / 8.7	17 / 72	0.48	19
		Connection size		1/4" / 35mm		Connection size		1/4" / 35mm	

DX COIL PERFORMANCE

Size T1

Max Air Volume Flow Rate (m³/s)		0.72				0.36			
R407C Liq. Temp. before TEV °C Average Evap. Temp. °C Superheat °K		Cooling Output kW total / sensible	Air Off Condition db (deg C) / Rh (%)	Mass flow rate kg / h	Coil dp bar / k	Cooling Output kW total / sensible	Air Off Condition db (deg C) / Rh (%)	Mass flow rate kg / h	Coil dp bar / k
45.0	10.0								
	25 / 50	7	17 / 82	163	0.19 / 0.9	3.5	17 / 82	82	0.04 / 0
Connection size (mm) twin coil interlaced		2 x 12.7 2 x 15.9 Gas 5 m/s				2 x 12.7 2 x 15.9 Gas 2.5 m/s			

Size T2

Max Air Volume Flow Rate (m³/s)		1.1				0.75			
R407C Liq. Temp. before TEV °C Average Evap. Temp. °C Superheat °K		Cooling Output kW total / sensible	Air Off Condition db (deg C) / Rh (%)	Mass flow rate kg / h	Coil dp bar / k	Cooling Output kW total / sensible	Air Off Condition db (deg C) / Rh (%)	Mass flow rate kg / h	Coil dp bar / k
45.0	10.0								
	25 / 50	12.4 / 10.9	16.8 / 80	293	0.82 / 3.9	10.2 / 8.1	16 / 80	240	0.55 / 2.6
Connection size (mm) twin coil interlaced		1 x 12.7mm Liquid line and 1 x 28 Gas line							

Size T3

Max Air Volume Flow Rate (m³/s)		7.4				5.4			
R407C Liq. Temp. before TEV °C Average Evap. Temp. °C Superheat °K		Cooling Output kW total / sensible	Air Off Condition db (deg C) / Rh (%)	Mass flow rate kg / h	Coil dp bar / k	Cooling Output kW total / sensible	Air Off Condition db (deg C) / Rh (%)	Mass flow rate kg / h	Coil dp bar / k
45.0	10.0								
	25 / 50	17.4	17 / 82	408	0.12 / 0.5	8.7	17 / 82	204	0.06 / 0
Connection size (mm) twin coil interlaced		2 x 12.7 2 x 22 Gas 6 m/s				2 x 12.7 2 x 15.9 Gas 6.2 m/s			

*Please note: above tables are based on indicative selections. For more specific selection, contact Nuair.

Size T2 continued

0.5				0.25			
Cooling Output kW total / sensible	Air Off Condition db (deg C) / Rh (%)	Water flow rate l/s	Water dp kPa	Cooling Output kW total / sensible	Air Off Condition db (deg C) / Rh (%)	Water flow rate l/s	Water dp kPa
7.1 / 5.1	16.52 / 73.9	0.283	6.8	3.8 / 2.8	15.85 / 76.8	0.151	3
Connection size 3/4" / 22mm				Connection size 3/4" / 22mm			

Code description for Chilled Water or Cooling Coils

CW TR 1 - 6/12 - 2.6

| | | | |
 1 2 3 4 5

- 1. = Chilled water or (CC) = Cooling coil
- 2. = Suitable for Thermal wheel (TWB)
- 3. = Unit size
- 4. = Flow and return temperature
- 5. = Return temperature
- 6. = Maximum air flow rate (m³/s)

Size T2 continued

0.5				0.4			
Cooling Output kW total / sensible	Air Off Condition db (deg C) / Rh (%)	Mass flow rate kg / h	Coil dp bar / k	Cooling Output kW total / sensible	Air Off Condition db (deg C) / Rh (%)	Mass flow rate kg / h	Coil dp bar / k
7.7 / 5.8	15.4 / 80	182	0.31 / 1.5	4.1 / 3.9	17 / 80	97	0.07 / 0
1 x 12.7mm Liquid line and 1 x 28 Gas line							

Code description for DX Coil

DX TR 1 - 2.6

| | | |
 1 2 3 4

- 1. = Type of coil
- 2. = Suitable for Thermal wheel (TWB)
- 3. = Unit size
- 4. = Maximum air flow rate (m³/s)

AIR HANDLING UNITS (AHU'S)

XBOXER COIL PERFORMANCE

TECHNICAL INFORMATION

STANDARD COIL PERFORMANCE

Size 1 Air Volume Flow rate (m³/s)		0.72				0.36				Flow & Return Connection size
LPH Water Flow & Return Temp. (C)	Entering Air Temp (C)	Heat Output (kW)	Air Off temp (C)	Water Flow rate (l/s)	Water dp (kPa)	Heat Output (kW)	Air Off temp (C)	Water Flow rate (l/s)	Water dp (kPa)	
82/71	-3	23	24	0.52	9.2	17	37	0.38	5.4	0.75" / 22mm
	3	21	28	0.48	8	16	39	0.35	4.6	0.75" / 22mm
	10	19	32	0.43	6.6	14	43	0.32	3.9	0.75" / 22mm
	15	18	35	0.4	5.7	13	45	0.3	3.4	0.75" / 22mm
80/60	-3	20	20	0.24	3	15	31	0.18	3	0.75" / 22mm
	3	18	24	0.22	3	13	34	0.165	3	0.75" / 22mm
	10	16	28	0.2	3	12	37	0.15	3	0.75" / 22mm
	15	14	31	0.18	3	11	40	0.13	3	0.75" / 22mm
60/40	-3	13	12	0.16	3	10	20	0.12	3	0.75" / 22mm
	3	11	15	0.14	3	8.5	22	0.1	3	0.75" / 22mm
	10	9	20	0.11	3	7	26	0.09	3	0.75" / 22mm
	15	7	24	0.09	3	6	28	0.07	3	0.75" / 22mm

Size 2 Air Volume Flow rate (m³/s)		1.1				0.75				0.5				Flow & Return Connection size
LPH Water Flow & Return Temp. (C)	Entering Air Temp (C)	Heat Output (kW)	Air Off temp (C)	Water Flow rate (l/s)	Water dp (kPa)	Heat Output (kW)	Air Off temp (C)	Water Flow rate (l/s)	Water dp (kPa)	Heat Output (kW)	Air Off temp (C)	Water Flow rate (l/s)	Water dp (kPa)	
82/71	-3	32.52	21.5	0.724	23.2	28.97	26.4	0.645	18.9	24.25	33.9	0.54	31.7	0.75" / 22mm
	3	29.9	25.9	0.665	20	26.55	30.5	0.591	16.1	22.2	37.5	0.494	11.7	0.75" / 22mm
	10	26.86	30.9	0.598	16.4	23.76	35.2	0.529	13.2	19.84	41.6	0.442	9.6	0.75" / 22mm
	15	24.7	34.4	0.55	14.1	21.79	38.5	0.485	11.3	18.18	44.5	0.405	12	0.75" / 22mm
80/60	-3	28.57	18.3	0.349	6.4	25.43	22.8	0.31	5.2	21.39	29.5	0.261	3.8	0.75" / 22mm
	3	25.96	22.6	0.317	5.4	23.04	26.9	0.281	4.4	19.37	33.1	0.236	3.2	0.75" / 22mm
	10	22.93	27.6	0.28	4.3	20.27	31.5	0.247	3.5	17.04	37.1	0.208	3	0.75" / 22mm
	15	20.77	31.2	0.253	3.7	18.32	34.8	0.224	3	15.39	40	0.188	3	0.75" / 22mm
60/40	-3	19.69	11.3	0.238	3.4	17.41	14.6	0.211	3	14.69	19.3	0.178	3	0.75" / 22mm
	3	17.07	15.6	0.207	3	15.05	18.6	0.182	3	12.7	22.7	0.154	3	0.75" / 22mm
	10	14.02	20.5	0.17	3	12.32	23.1	0.149	3	10.4	26.6	0.126	3	0.75" / 22mm
	15	11.82	24	0.143	3	10.38	26.2	0.126	3	8.76	29.2	0.106	3	0.75" / 22mm

Size 3 Air Volume Flow rate (m³/s)		1.8				0.9				Flow & Return Connection size
LPH Water Flow & Return Temp. (C)	Entering Air Temp (C)	Heat Output (kW)	Air Off temp (C)	Water Flow rate (l/s)	Water dp (kPa)	Heat Output (kW)	Air Off temp (C)	Water Flow rate (l/s)	Water dp (kPa)	
82/71	-3	81	34	1.81	8.7	56	49	1.26	4.9	1.25" / 35mm
	3	75	37	1.66	7.5	52	51	1.15	4.3	1.25" / 35mm
	10	67	41	1.49	6.3	46	53	1.04	3.6	1.25" / 35mm
	15	61	43	1.36	5.5	43	54	0.95	3.2	1.25" / 35mm
80/60	-3	65	27	0.8	3	46	39	0.56	3	1.25" / 35mm
	3	59	30	0.72	3	42	41	0.51	3	1.25" / 35mm
	10	51	33	0.62	3	36	43	0.44	3	1.25" / 35mm
	15	45	36	0.55	3	32	44	0.39	3	1.25" / 35mm
60/40	-3	37	15	0.47	3	27	22	0.33	3	1.25" / 35mm
	3	32	17	0.38	3	22	23	0.26	3	1.25" / 35mm
	10	22	20	0.27	3	11	20	0.13	3	1.25" / 35mm
	15	10	20	0.12	3	9	23	0.11	3	1.25" / 35mm

The thermal outputs in these tables represent the results that may be achieved with the range of standardised coils offered in this range of equipment. Heating coils may of course be individually selected to meet project specific requirements.

*Please note: above tables are based on indicative selections. For more specific selection, contact Nuair.

*Please note that the pressure drops shown are for the bare coil only. Please contact Nuair for further information.



FROST COIL PERFORMANCE

Size 1 Maximum Air Volume

Flow rate (m³/s)

LPH Water Flow & Return Temp. (C)	Entering Air Temp (C)	Heat Output (kW)	4			3			2			Connection size		
			Air Off temp (C)	Water Flow rate (l/s)	Water dp (kPa)	Heat Output (kW)	Air Off temp (C)	Water Flow rate (l/s)	Water dp (kPa)	Heat Output (kW)	Air Off temp (C)		Water Flow rate (l/s)	Water dp (kPa)
82/71	-3	119	21.6	2.7	6.9	108	26.7	2.4	5.9	90.3	34.3	2	4.4	00"/00mm
80/60	-3	98.5*	17.3	1.3	3	89.3**	21.7	1.1	3	74**	28.5	0.91	3	*00"/35mm **0"/00mm
60/40	-3	63*	9.5	0.77	3	57**	12.2	0.69	3	48**	16.4	0.58	3	*00"/35mm **0"/00mm

Size 2 Maximum Air Volume

Flow rate (m³/s)

LPH Water Flow & Return Temp. (C)	Entering Air Temp (C)	Heat Output (kW)	6.6			4.5			3			Connection size		
			Air Off temp (C)	Water Flow rate (l/s)	Water dp (kPa)	Heat Output (kW)	Air Off temp (C)	Water Flow rate (l/s)	Water dp (kPa)	Heat Output (kW)	Air Off temp (C)		Water Flow rate (l/s)	Water dp (kPa)
82/71	-3	287	30	6.4	11.1	249	39.1	5.5	8.9	180	51.9	4	5.4	*0"/00mm **00"/00mm ***00"/00mm
80/60	-3	239	27.6	2.92	3.4	213	32.9	2.6	3	173	40.8	2.1	3	*00"/00mm ** 00"/00mm
60/40	-3	162	15.7	1.97	3	140	20.6	1.7	3	114	25.9	1.38	3	*00"/00mm ** 00"/00mm

Size 3 Maximum Air Volume

Flow rate (m³/s)

LPH Water Flow & Return Temp. (C)	Entering Air Temp (C)	Heat Output (kW)	10.1			7.5			5			Connection size		
			Air Off temp (C)	Water Flow rate (l/s)	Water dp (kPa)	Heat Output (kW)	Air Off temp (C)	Water Flow rate (l/s)	Water dp (kPa)	Heat Output (kW)	Air Off temp (C)		Water Flow rate (l/s)	Water dp (kPa)
82/71	-3	443	30.3	9.86	33.8	392	36.7	8.7	27.7	319	45.4	7.09	19.8	*0"/00mm **00"/00mm
80/60	-3	378	25.5	4.62	10.2	337	31.1	4.1	8.6	276	38.9	3.37	6.4	*00"/00mm **00"/00mm
60/40	-3	251	15.9	3.1	5.7	224	19.7	2.71	4.8	185	25	2.74	3.6	*00"/00mm **00"/00mm

The thermal outputs in these tables represent the performance of coils selected to achieve our recommended operational specifications for a frost protection coil. Alternative coil specifications may be provided on request.

*Please note: above tables are based on indicative selections. For more specific selection, contact Nuair.

*Please note that the pressure drops shown are for the bare coil only. Please contact Nuair for further information.

Code descriptions

FC TR 1 - 82/71 - 4

| | | | | |
1 2 3 4 5 6

- 1. = Frost coil
- 2. = Suitable for Thermal wheel (TWB)
- 3. = Unit size
- 4. = Flow temperature
- 5. = Return temperature
- 6. = Maximum volume flow rate (m³/s)

AIR HANDLING UNITS (AHU'S)

XBOXER ANCILLARIES

TECHNICAL INFORMATION

WEATHER PROTECTION ROOF FOR XBOXER THERMAL WHEEL & RUN AROUND COIL UNITS

*Note: Weather protection is also available for other stacked and horizontal units in the XBOXER range.

For further information contact Nuairé.

An example of a stacked unit with weather roof is shown below. Note: These roofs do not provide frost protection.

For Weather Protection add 'WP' to end of unit code i.e. T3-TWB-LLWP.

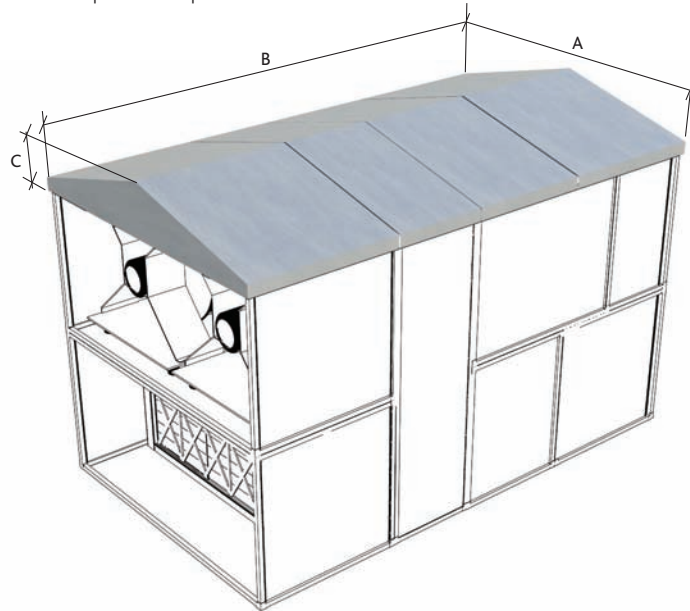

DYNAMIC INSERTION LOSS (dB)

Length	125	250	500	1K	2K	4K	8K
900	6	8	18	22	20	16	15

MOTORISED DAMPER

Opposed blade design with quick fit flanges. 240V Open/Shut model for efficient back draught protection. (24V modulating version for balancing and control available on request).

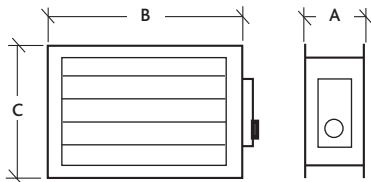

DIMENSIONS (mm)

Unit	A	B	C	Weight (Kg)
MD-TR-1	165	760	395	15
MD-TR-2	165	960	494	20
MD-TR-3	165	1200	590	40

Note: Dimensions B & C are to suit unit supplied.

TWB & RAC WEATHER PROTECTION

DIMENSIONS (mm)

Unit Code	A	B	C	Weight (Kg*)
T/1 -TWB-*WP	1070	1470	112	40
T/2 -TWB-*WP	1070	1470	112	50
T/3 -TWB-*WP	1200	2000	100	60

*Weight of weather roof only.

NON MOTORISED DAMPER

Non motorised dampers are available, contact Nuairé.

Please contact Nuairé for manometers, gauges, sensors, traps and drains, condensate pumps, access panels, view ports and bulkhead lights.

BASE FRAME

Base Frame is included.

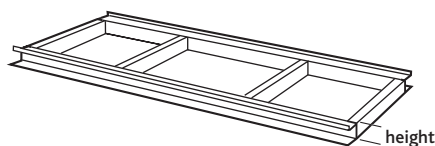

DIMENSIONS (mm)

Unit Code	Height of base frame
T1, T2 and T3	100

CONDENSATE PUMP



DIMENSIONS (mm)

Unit Code	L x W x H	Weight (Kg)
XB-CON-DR	267 x 51 x 64	1

WIRING FOR UNITS WITH ECOSMART CONTROL - T1 - TWB 'L' (LPHW)

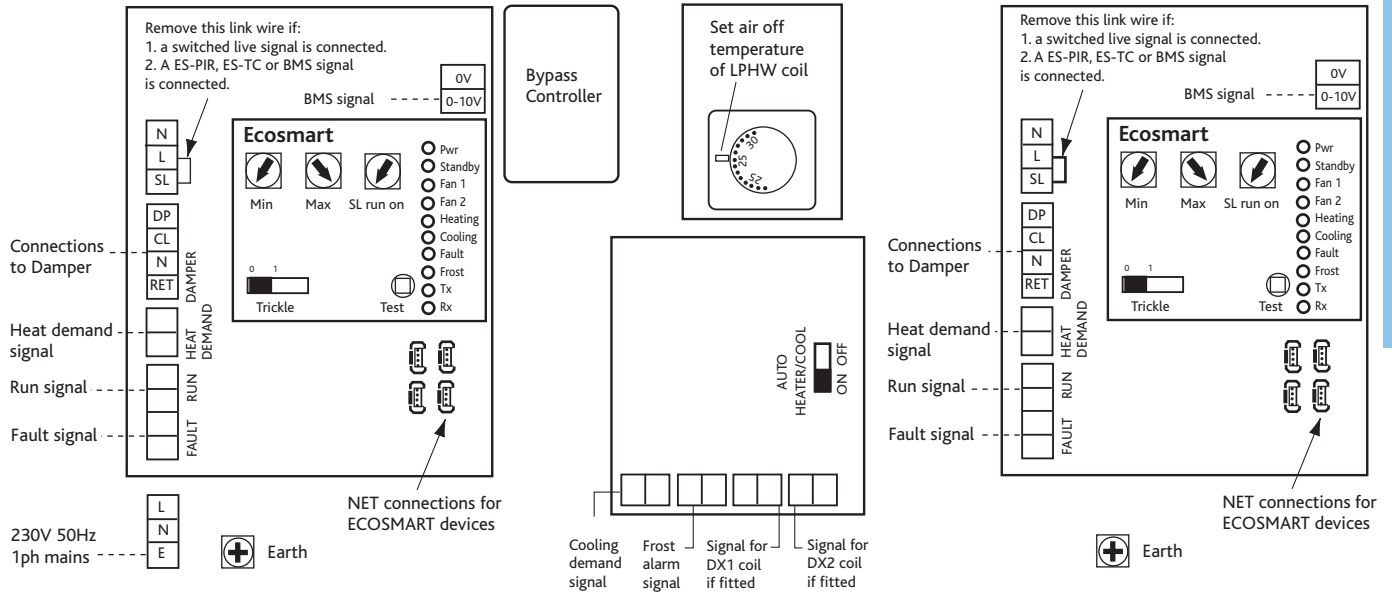

WIRING FOR UNITS WITH ECOSMART CONTROL - T2 - TWB 'L' (LPHW)

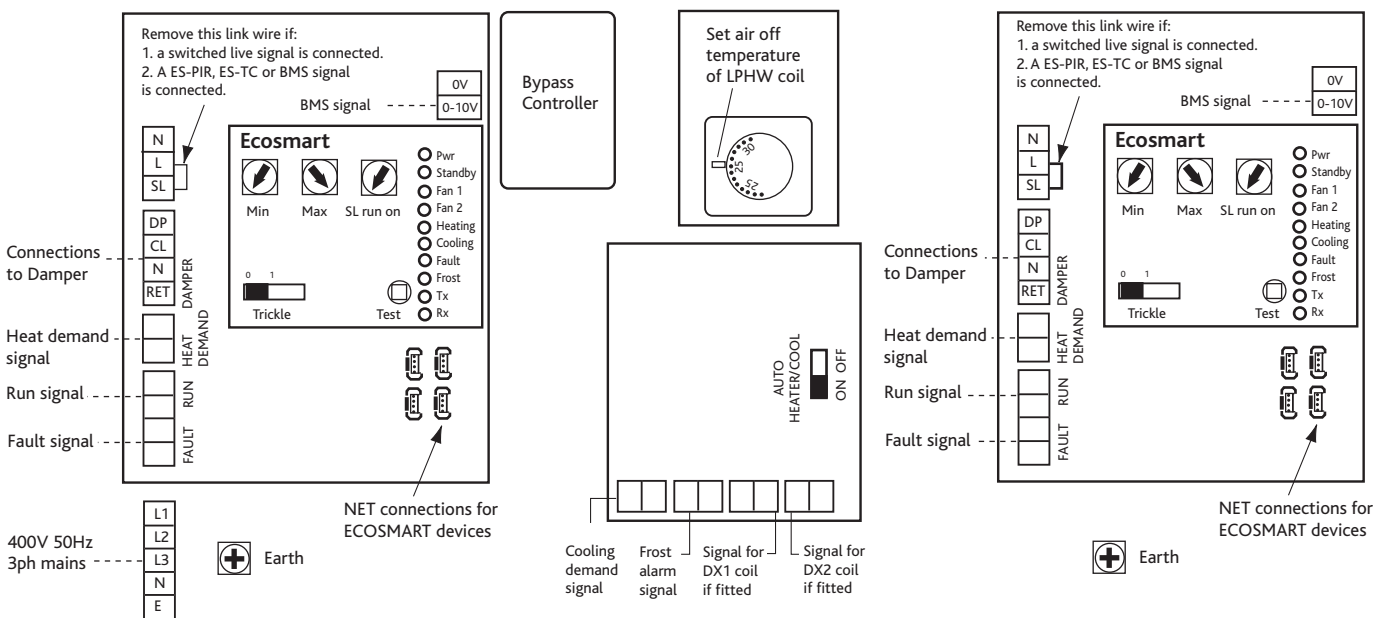

CONSULTANTS SPECIFICATION

XBOXER THERMAL WHEEL

OPERATION

The supply and extract ventilation unit shall be as indicated on the drawings and shall be in accordance with the particular fan schedule in the specification. Supply air to the room shall be pre-heated by the extract air via the integrated thermal wheel or run around coil.

Where fitted an integrated heater battery shall raise the temperature of the supply air to the design room temperature after the air has passed through the thermal wheel or run around coil.

The Ecosmart ventilation unit shall automatically vary the ventilation rate, as it receives signals from one of the optional interconnected sensors. When signals are received, the fan shall either vary its speed proportionally or on a trickle and boost principle.

The unit shall have the facility to commission the supply and extract fans individually via inbuilt minimum and maximum speed adjustment, the fans themselves shall have infinitely variable speed control.

RANGE TYPE - THERMAL WHEEL UNIT

The vertically stacked unit shall be manufactured from aluzinc corrosion resistant steel, with 25mm double skinned infill panels and extruded aluminium frame giving extremely low noise levels. The unit shall include the following items:- Thermal wheel, supply & extract fans, supply and extract filters, G4 grade bag as standard (upgrade to F7 bag if required) and LPHW heating coil (L model). The unit shall be constructed with removable panels allowing maintenance access from either side. Note: T1, T2 & T3 have chosen side access.

The unit shall be constructed with removable panels allowing full maintenance access from either side.

CONTROL TYPES - ECOSMART - (OPTIONAL)

The Ecosmart control option provides the facility for energy saving via an intelligent stand-alone AHU function, or for convenient integration with client BMS with a minimal coordination requirement.

The factory fitted control includes:- integral infinitely variable (inverter) speed / duty control for the supply and extract fans, with independent minimum and maximum adjustment for accurate commissioning.

A run on timer and "background" ventilation function and is provided as is unit status indication, run / fail relays, and interface connection for Ecosmart sensors/enablers and system dampers.

The unit heat recovery function is facilitated by a dedicated controller and associated sensors. An output signal is provided to control thermal wheel drive or plate heat exchanger bypass operation (included), For Run Around Coil units, the output signal may be used to control the circulation pump system (by others).

BMS. The Ecosmart control module can additionally be pre-configured to provide the following integrated BMS interfaces.

- 0 - 10 volt contacts to provide a full BMS interface. This will enable the following functions:-
Switch the unit ON/OFF.
Variable speed / duty control Switch from low speed to high speed - trickle and boost principle.

- 2 No. Volt free contacts to provide fan run and failure indication to provide system status.

Please note Ecosmart is fan only control.

NO CONTROL - (OPTIONAL)

Unit provides side access to direct supply and extract fan motor wiring (terminal boxes) for interface to custom built control panels by others. For this option, no sensors are fitted to the unit, but note that in the case of plate heat exchanger units, the bypass damper actuator is included, and for thermal wheel units, the wheel motor and drive unit is included.

ELECTRIC HEATER BATTERY

The electric heater battery shall be factory fitted and pre-wired to an integral closed loop thyristor control. When the unit is switched off, the fan shall continue to run to dissipate heat from the electric heater battery before stopping.

COIL TYPES - LOW PRESSURE HOT WATER COIL

The coil casing shall be formed from heavy gauge galvanised sheet steel to BS 2989 to make a rigid assembly. Tube end plates shall have die formed collared holes to allow expansion and contraction of the tubes without damage.

All coils are pressure tested to 16 bar with dry compressed air under water.

Standard or duty specific coils are selected to suit customer requirement using specific computer software to give optimum performance with lowest pressure drop.

The coils shall be factory fitted with drain cocks and air vents.

Standard specification coils have copper tubes and aluminium fins.

Coil connections shall be BSP terminated at the exterior of the unit casing. T1, T2 & T3 will have push fit connections.

CONSULTANTS SPECIFICATION

XBOXER THERMAL WHEEL

COOLING COILS - CHILLED WATER (OPTIONAL)

The coil casing shall be formed from heavy gauge galvanised sheet steel to BS 2989 to make a rigid assembly. Tube end plates shall have die formed collared holes to allow expansion and contraction of the tubes without damage. All coils are pressure tested to 16 bar with dry compressed air under water. Standard or duty specific coils are selected to suit customer requirement using specific computer software to give optimum performance with lowest pressure drop. The chilled water coils shall be factory fitted with drain cocks and air vents.

Standard specification coils shall have copper tubes and aluminium fins, and shall be supplied complete with an insulated condensate tray with drain connection, and moisture eliminator. Coil connections shall be BSP terminated at the exterior of the unit casing. T1, T2 & T3 will have push fit connections.

COOLING COILS – DX COIL (OPTIONAL)

The coil casing shall be formed from heavy gauge galvanised sheet steel to BS 2989 to make a rigid assembly. Tube end plates shall have die formed collared holes to allow expansion and contraction of the tubes without damage. All coils are pressure tested to 16 bar with dry compressed air under water. Standard or duty specific coils are selected to suit customer requirement using specific computer software to give optimum performance with the chosen refrigerant.

The DX coils shall be of twin coil interlaced type unless otherwise stated (c/w two pairs of connections). Standard specification coils shall have copper tubes and aluminium fins, and shall be supplied complete with an insulated condensate tray with drain connection, and moisture eliminator. Coil connections shall be BSP terminated at the exterior of the unit casing.

ANCILLARIES FOR TWB - ATTENUATORS

Attenuator splitters shall be manufactured from using chemically inert, non-combustible, non-hygroscopic and vermin resistant sound absorbing material, with fibre-retaining facing. Attenuator casing shall be manufactured from aluzinc corrosion resistant steel, with 25mm double skinned infill panels and extruded aluminium frame.

Attenuator shall be tested in accordance with BSI 4718: 1971 ASTM E 477 and shall be suitable for external/internal use.

CODE FOR ATTENUATORS

SIL-TR-1 (to fit thermal wheel unit).

SIL-TR-2 (to fit thermal wheel unit).

SIL-TR-3 (to fit thermal wheel unit).

MOTORISED DAMPERS

Motorised damper shall be of opposed blade type and come complete with quick fit flanges as standard. Damper is 240V open/shut type designed for efficient back draft protection.

CODE FOR DAMPERS

MD-TR1 (to fit size 1-TWB**)

MD-TR2 (to fit size 2-TWB**)

MD-TR3 (to fit size 3-TWB**)

Note: above are suitable for both Thermal wheel and run around coil ranges.

WEATHER KIT

Manufactured from Aluzinc the weather proof enclosure is designed for Nuaire thermal wheel and run around coil ranges. Kit's can be factory fitted or installed on site. Note: enclosure does not provide frost protection.

XBOXER THERMAL WHEEL & RUN AROUND COIL

CODE (FOR THERMAL WHEEL MODELS)

T1-TWB-L L 2 WP

T2-TWB-R L 2 WP

T3-TWB-L N WP

T1-TWB-R N WP

T2-TWB-L E WP

T3-TWB-R E WP

* Denotes handing, 'L' = left, 'R' = right.

Models with Ecosmart control will have a 5 year warranty.

Models with no control will have a 2 year warranty.

For further details contact Nuaire.

Note: Thermal wheels have specific maintenance requirements, contact Nuaire for details.



Tailor-made AHUs up to 20m³/s.

“XBOXER. Custom-made air handling. Improving the climate in any environment.”

Supermarkets



Apartments

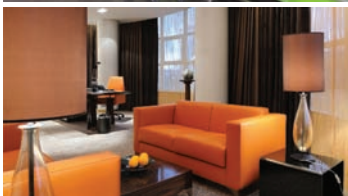

Offices and more



Nuaire’s XBOXER range is built around our customers’ needs.

Covering all the most common functions in ten of the most common sizes, our pre-configured range offers horizontal, vertical and twin-fan options with duty range of up to 8m³/s and all units available with Ecosmart, the innovative energy-efficiency control.

The range is impressive.

But there’s more. Because at Nuaire we recognise that sometimes there are applications with very special demands.

Which is why XBOXER now offers customised solutions giving customers the flexibility to combine modules to build tailor-made AHUs up to 20m³/s. The range can meet specific needs, for example when a humidifier or components in a specific finish are required. While pre-configured and tailored solutions can also be combined to achieve the optimum result. Making XBOXER the most flexible range available.

Pre-configured or custom-made, it’s made for our customers.

Nuaire. The air of true innovators.



For more details [please refer to main AHU catalogue.](#)