

E-STACK (R-SERIES) ROOF BASED VENTILATION SYSTEMS

LOW ENERGY NATURAL VENTILATION SOLUTIONS DESIGNED FOR TOP FLOOR CLASSROOMS AND OFFICES OR ROOMS WHICH HAVE ACCESS TO THE ROOF THROUGH SHAFTS.



BENEFITS

Designed specifically for rooms occupied by 10 to 35 people (per unit), the R-Series is ideal for top floor classrooms and offices, and for rooms one floor below the top floor of a multi-storey building.

SUMMER

When it's warm outside, the system operates most effectively if air is allowed to enter the space through low level openings. Pre-heating is not required, and the system operates in upflow displacement mode. The damper in the R-Series unit opens as temperatures in the space rise, to maximise airflow and minimise heat build-up.

WINTER

With the R-Series unit accessing the exterior air through the roof of the room or hall, the system uses a mixing ventilation strategy when the external air is too cool to bring in directly on to occupants.

Fresh air is brought in through one side of a divided shaft above the R-Series unit and mixed.

At the same time the warm, polluted air is drawn out of the room and vented to the outside through the other section of the divided shaft.

By using this strategy, the heat gains which arise in the room through the use of lights, computer equipment and body heat, are used to heat the incoming air.

The system uses far less energy than conventional radiator-based systems which heat cold air as it enters the room at low level.

By avoiding the need to pre-heat incoming air.

KEEPING CONTROL

The ventilation system is fully controlled with dedicated temperature and CO₂ sensors in the space. This allows the system to optimise ventilation for maximum comfort and low energy use. Duct temp sensors ensure the unit reduces incoming airflow appropriately.

NIGHT COOLING

After periods of warmer temperatures, the R-Series unit automatically cools the space overnight without compromising building security. After the designated occupied day, the damper in the unit opens, allowing the space to naturally exchange air with the cooler exterior. The low energy fans in the unit will assist the night cooling if required.

ATTENUATION

Attenuation can be provided to suit individual site requirements. Contact Nuaire for details.

WARRANTY

The R-Series has a 3 year warranty.

TYPICAL INSTALLATION OF E-STACK R-SERIES UNIT & ROOF TERMINAL

The R-Series units are perfectly suited to school and office areas with their high occupancies and heat gains. The units are sized to conform with the BB101 criteria for typical classrooms, and meet not only summertime overheating requirements, but also the minimum daily average ventilation requirements to limit room CO₂ levels. The units can also ventilate to meet CIBSE Guide A criteria.

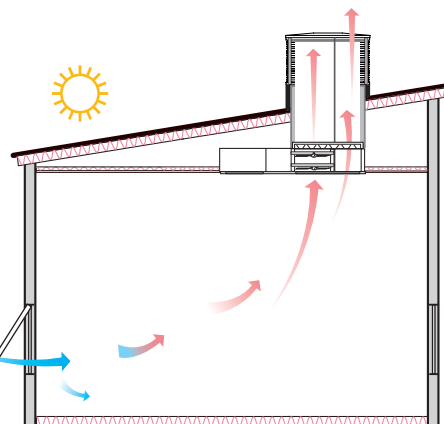

Unit shown in summer operation.

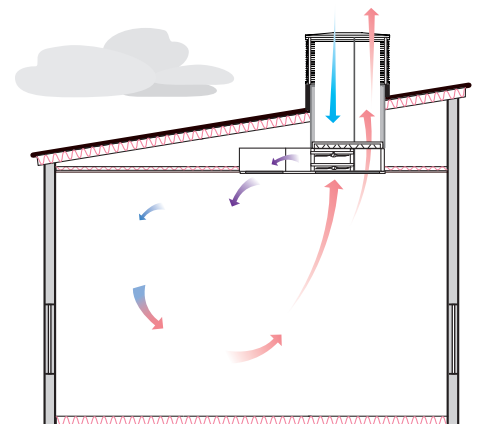

Unit shown in winter operation.

INSTALLATION OF THE R-SERIES UNITS

Whilst Nuair provide recommendations for the installation of supports for the units, the sizing and detailed design of the load-bearing supports must be specified and signed off by the structural engineers for the project.

Two fixing methods are suggested:

1. Vertical support studding attaches to either side of a cradle which supports the e-stack unit. The cradle can be formed from two unistrut channels.

2. e-stack mounting brackets supplied and used in conjunction with drop-rods to support the units. The ventilation unit hangs from 4no. pieces of M12 studding of maximum length 1200mm.

The drop-rods are attached to the R-Series unit using welded brackets.

The bracket length is 69mm to the centre of the fixing hole.

The unit is lifted into place and four M12 Studding (drop-rods) are brought through the holes on the end of the welded brackets, positioned and secured in place using a pair of M12 full nuts per bracket.

Casing



Code description (Example)

NVR

| |
1 2

1 = Natural Ventilation range

2 = R-Series

R-SERIES FRESH AIR FLOW RATE & SOUND POWER LEVELS FOR ONE UNIT

Winter Mode Mixing - Slow

Octave Band (Hz)	63	125	250	500	1K	2K	4K	8K	Overall (dBA)
Sound Power Level (dB)	41.2	46.5	38	35.3	30.3	25.5	20.2	24.3	36.8

Winter Mode Mixing - Fast

Octave Band (Hz)	63	125	250	500	1K	2K	4K	8K	Overall (dBA)
Sound Power Level (dB)	43.5	49.7	40.9	37.5	33.9	27.9	18.0	24.4	39.6

Summer Fan Assist

Octave Band (Hz)	63	125	250	500	1K	2K	4K	8K	Overall (dBA)
Sound Power Level (dB)	43.6	45.8	41.7	39.6	36.7	28.7	21.4	24.4	41.1

SHAFT DETAIL R-SERIES

Typical installation section through an R-Series unit (right) visible in the space. The unit has been installed below a concrete slab. In some projects it can be possible to locate the unit within ceiling voids, /bulkheads.

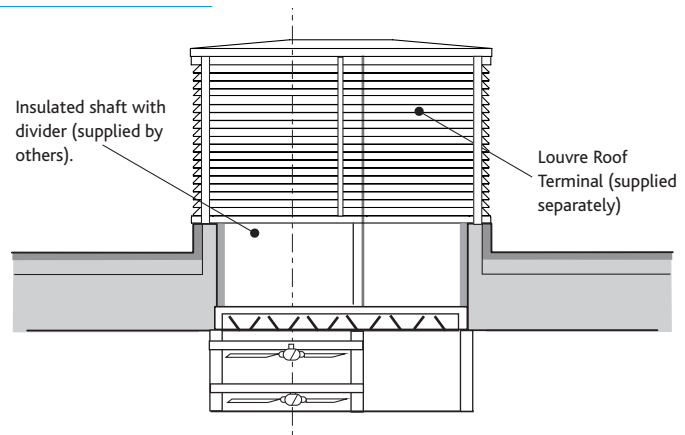

Typical shaft detail. A divided, insulated shaft between each R-Series unit and roof termination is required.

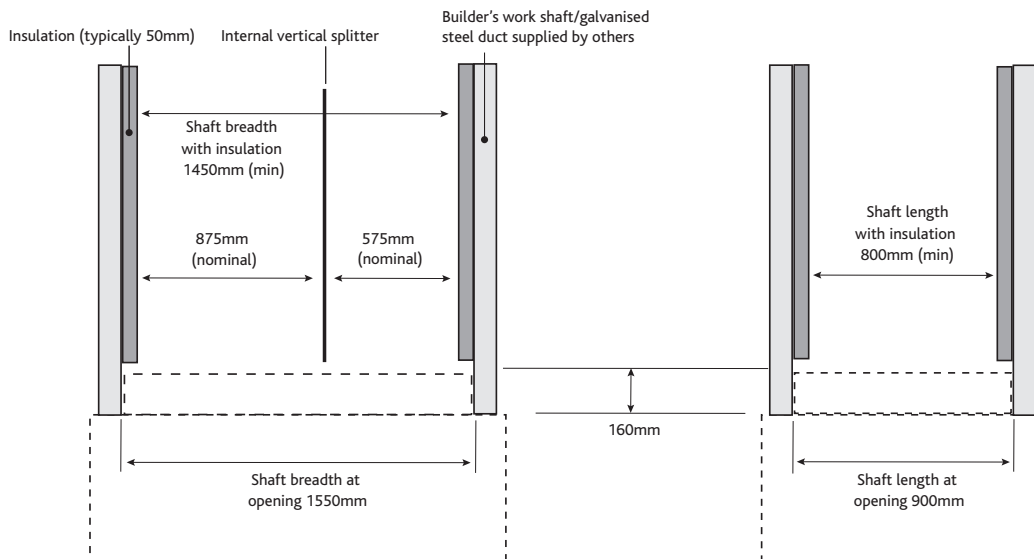

TYPICAL INSTALLATION METHODS FOR AN E-STACK UNIT

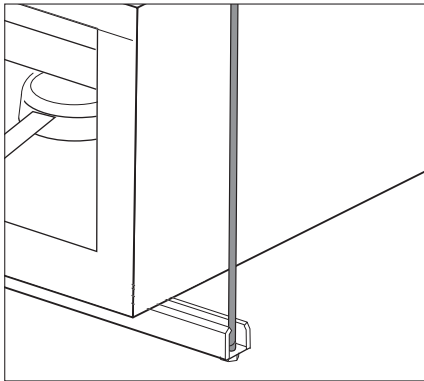

Option 1. Unistrut channel cradle.

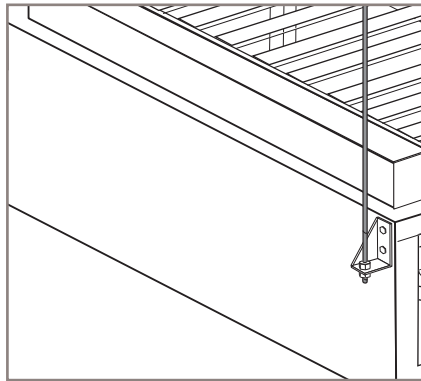

Option 2, showing drop rods attached to unit.

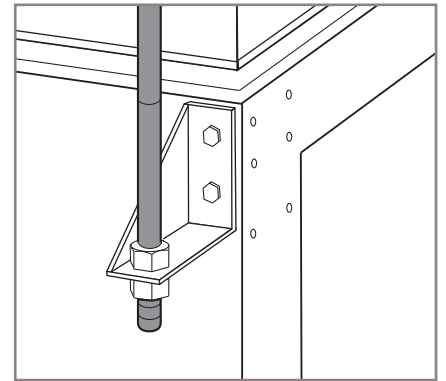

Option 2, close up of bracket.

DIMENSIONS (mm) - R-SERIES

Plan view

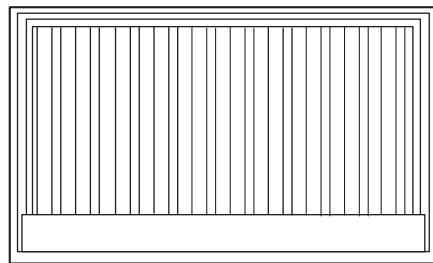

Side view

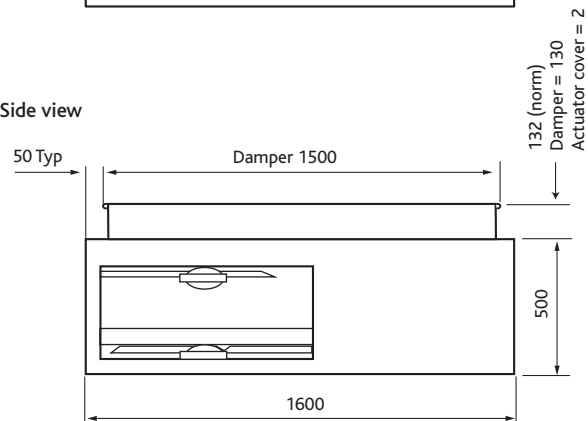

End view

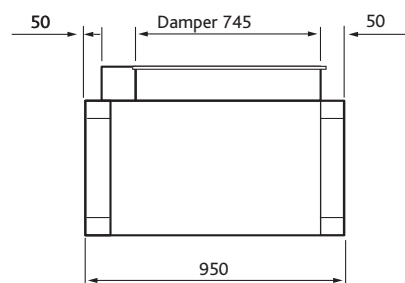

TYPICAL R-SERIES WIRING LAYOUT

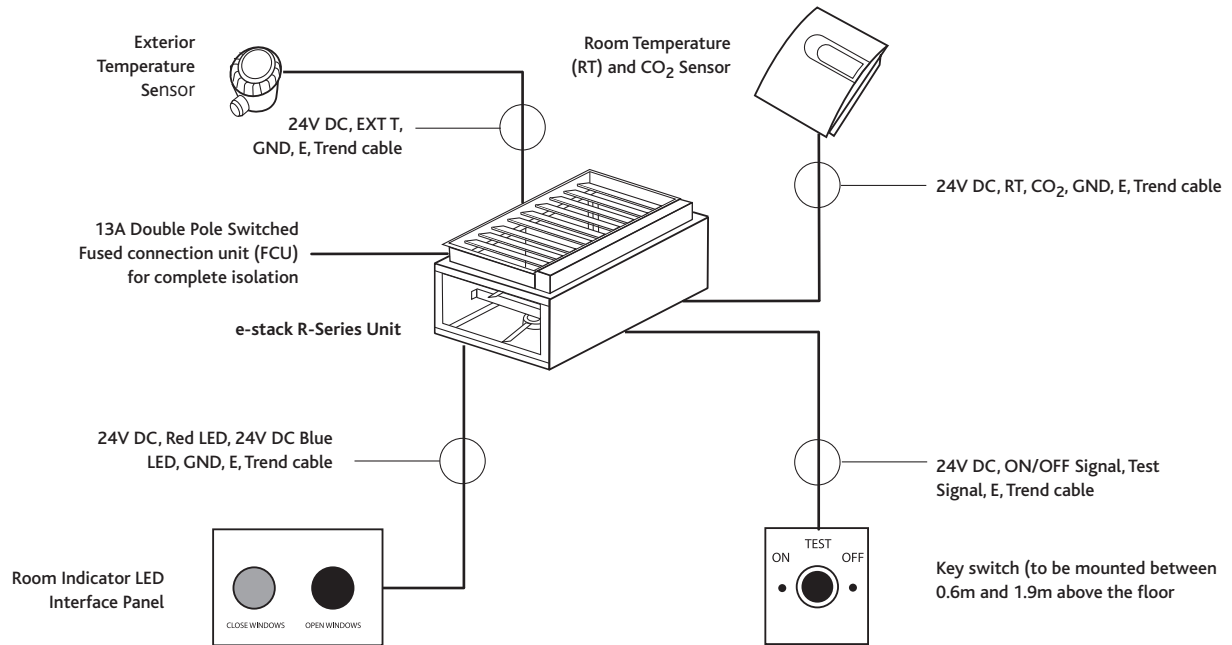

Note: Trend cable = TP/2/2/22/HF/200

MECHANICAL AND ELECTRICAL SPECIFICATION R-SERIES

Dimensions:	1600mm (L) x 950mm (W) x 500mm (H) (630mm high incl. damper housed in shaft).
Shaft requirements:	Shaft aperture 1550mm x 900mm.
Weight:	150kg.
Construction:	Galvanised steel or Zintec.
Recommended fixing methods:	Via drop rods and cradle arrangement (by others) or brackets. Rubberised seal on top flange provides airtightness to shaft.
Colour:	Standard galvanised finish or Zintec powder coated to RAL9010 at additional cost. (other RAL and BS colours available).
Damper:	Actuated insulating low-leakage volume control damper with fully modulating rotary actuator.
Controller:	Internal controller to operate fans and dampers in response to sensed environmental conditions. Additional control signals for automated high / low level openings can be supplied if required.
Sensors:	Combined interior temperature / CO ₂ sensor. External temperature sensor.
User interface:	Key switch (on / off / test mode), Red / blue "Open/Close Windows" indicator panel. (for low level manually opening windows).
Voltage:	230V single phase, 50Hz.
Power Consumption:	0.1kW.
Full load current:	0.43A.
Short circuit rating:	N/A, Control circuits only.
Earth leakage:	<3.5mA.

CONSULTANTS SPECIFICATION

SYSTEM DESCRIPTION

The spaces shall be provided with an automatic ventilation system to meet fresh air ventilation requirements in line with the BB101 or CIBSE Guide A guidelines for ventilation. The system shall be designed to prevent summertime overheating and shall maintain a daily average of 5l/s/person (BB101) or 10l/s/p (CIBSE Guide A) of fresh air all year round.

The system shall include a ventilation unit incorporating insulated dampers, an internal mixing system, induction fans and an integral controller.

The unit shall be connected to grilles in the room and to a shaft leading to an external weatherproof penthouse louvre unit above.

The ventilation shaft from the room to the weatherproof penthouse louvre is to be provided by others and is a builders work requirement.

The penthouse louvre units shall incorporate weatherproof louvres with the required aerodynamic effective area to ventilate the rooms.

SYSTEM OPERATION

In winter - the ventilation shaft shall be used for fresh air intake & exhaust. The unit at the base of the shaft shall mix the incoming cold air with sufficient hot interior air prior to the fresh air entering the occupied space in order to minimize the risk of cold draughts, and the requirement for pre-heating of air using hot water coils or similar.

In summer - the unit will operate as a buoyancy-driven natural ventilation system. It shall have the ability to automatically induce buoyancy to the direction of desired airflow via an integrated induction fan. The fan shall operate automatically as the conditions within the space vary.

Once the fan has induced the airflow it shall return to its standby mode, allowing the system to function entirely under the relative buoyancy. The unit will work in conjunction with openable windows on the external façade of the space, providing a crossflow ventilation effect with air being drawn through the room into the unit and discharged to atmosphere via the builders work shaft.

The roof mounted units shall incorporate a bird guard, plus a section designed to attenuate rain noise, and polyester powder paint finish to the required standard RAL colour if required.

CONTROL SPECIFICATION

Each ventilation unit shall be automatically controlled via a combined temperature / CO₂ sensor located in each room together with a common external temperature sensor to determine the operation of the unit. The ventilation unit shall be capable of providing automatic, secure night cooling, allowing cool air to enter the space via the unit, utilizing the integrated fan to induce the flow if the conditions in the space require it.

A 2-gang switch plate with lamps to indicate when windows should be open/closed together with key switch for activating On / Off / Test mode will be located in each room. Position of the indicator lamps and key switch to be as indicated on the tender drawings and co-ordinated with any other electrical components required in the space.

The R-Series has a 3 year warranty comprising of first year parts and labour with remaining two years parts only.

The equipment shall be the e-stack R-series as supplied by Nuair.