

DRIMASTER 2000 - POSITIVE INPUT VENTILATION (PIV)

LOW COST WHOLE HOUSE VENTILATION WITH INTELLIGENT HEAT RECOVERY THAT MEETS BUILDING REGULATIONS, SAVES ENERGY AND PREVENTS CONDENSATION.

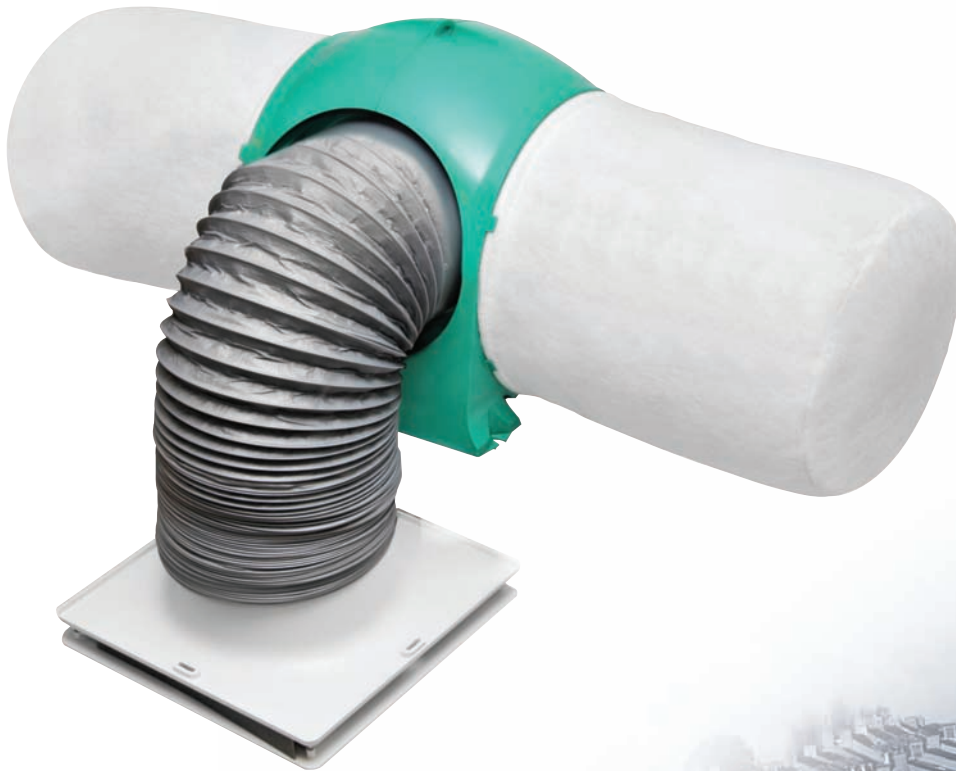

Sensor/Indicator

BENEFITS

EXTREMELY LOW POWER CONSUMPTION

Average approximately 0.16 watts / litre / second and solar gains up to 550kW / hr / year.

EASY INSTALLATION & VERY LOW MAINTENANCE REQUIREMENT

Filter clean or replacement every 5 years.

SIGNIFICANTLY IMPROVES INDOOR AIR QUALITY

Using positive input ventilation removes indoor air pollutants such as carbon monoxide and keeps out traffic fumes, pollen and outdoor pollutants.

INTELLIGENT HEAT RECOVERY

Twin sensors optimise energy efficiency, adjusting settings to provide increased comfort.

COMPLIES WITH THE BUILDING REGULATION VENTILATION REQUIREMENTS

Meets Part F&L England and Wales and contributes towards 'conservation of fuel and power'. (Please refer to BBA Certificate).

CREATES A HEALTHIER LIVING ENVIRONMENT

High efficiency G4 filters removes up to 95% dust particles.

FIT & FORGET OPERATION

Fully automatic when airflow set on installation.

FIRE DAMPER AND DIFFUSER FOR 3-STOREY ACCOMMODATION AVAILABLE

The diffuser is manufactured from aluminium and powder coated to an off white finish (RAL 9003). Product code Drimaster-3S.

SYSTEM STANDBY MODE

For summer months when loft temperature exceeds 23°C.

HEALTH

Clinically proven to help allergy and asthma sufferers.

OPTIONAL BOOST FACILITY

When additional ventilation is required i.e. cooking odours etc.

WARRANTY

5 year warranty for peace of mind.

INSTALLATION OPTIONS

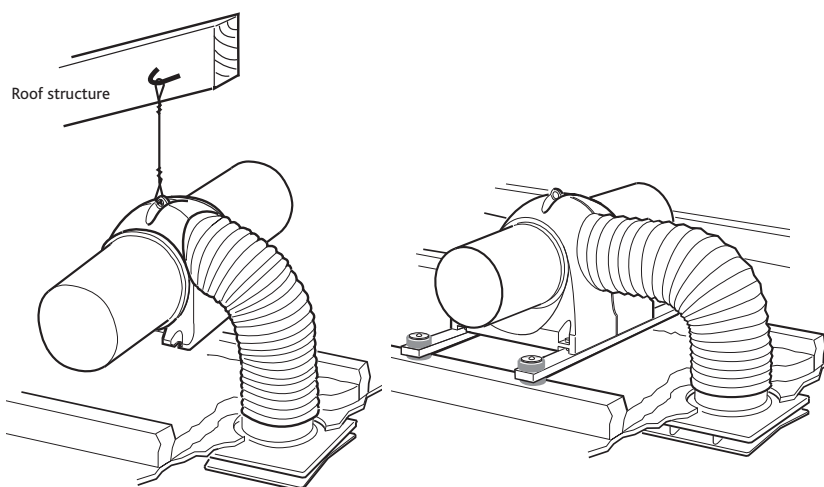

Standard method of fixing.

Optional method of fixing. (AV mounting kit onto roof joists).



Ceiling diffuser.



DRIMASTER 2000

The Drimaster 2000 provides whole home ventilation using the Positive Input Ventilation principle. Essentially the concept is to introduce fresh, filtered air into the dwelling at a continuous rate, encouraging movement of air from inside to outside. To achieve this, the unit is mounted in the loft space, drawing air through the filters and inputting it, at ceiling level, into the property.

Siting the Remote Sensor

The Remote Temperature Sensor incorporates a clip-in fixing bracket which can be removed for easy fitting to a suitable surface.

Select a suitable location for the sensor e.g. close to ceiling height in a bedroom or hallway BUT NOT WITHIN 3 METRES of the diffuser.



AIR DIFFUSER WITH FIRE DAMPER

For use in stairwells of three storey properties, the optional powder-coated aluminium diffuser with 'Fireblock' provides 1 hour of fire resistance in accordance with BS476 Part 20 and ISO834.

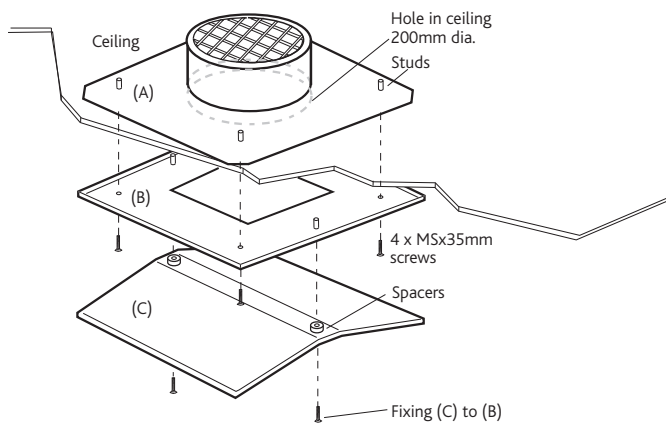

WIRING

The unit is supplied with a pre-wired power supply. This power supply unit has a metal bracket incorporating fixing holes, which should be used to fit the power supply to a suitable surface e.g. a wooden joist.

The fan unit is also supplied with a fused spur. The two core mains cable from the power supply should be connected to a fixed wiring installation, via the isolator, via the spur, in accordance with current IEE wiring regulations.

Optional 'BOOST' facility

The unit air volume can be manually boosted to maximum speed by wiring in a simple one way switch (Part No. 773532) into the wire supplying the sensor. By switching the unit to 'BOOST' all other functions are over-ridden.

Electrical details:-

- Voltage:** 240V 1ph 50Hz
- Consumption:** 1.6W(min) 15.3W(max)
- Fuse size:** 1 Amp

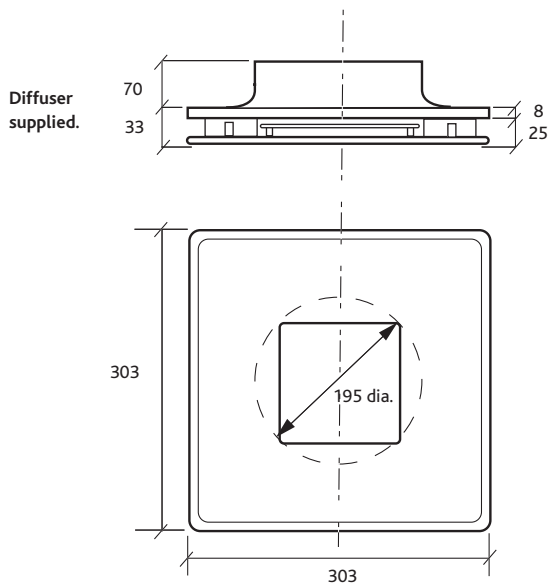

DIMENSIONS (MM) & WEIGHT DRIMASTER 2000 UNIT

Weight: 5.7kg

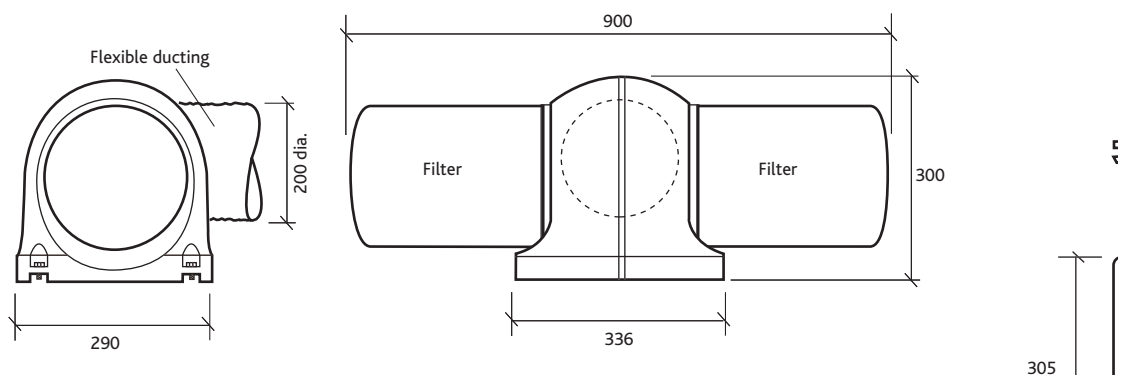

CONSULTANTS SPECIFICATION

FAN DESCRIPTION

Low energy positive input ventilation unit - for use in homes with a loft.

The unit shall be robustly constructed from flame retardant VO rated ABS polymer and the casing shall be of spherical pattern with a flat mounting base.

Flame retardant filters of G4 grade, surface area approx 0.47m² (with 5 year typical maintenance period) shall be fitted, which may be removed from the unit without the use of tools. The filters shall be arranged such as to prevent their obstruction in the loft space.

The unit shall incorporate a forward curved centrifugal impeller and high efficiency brushless DC motor fitted with sealed for life, self lubricating bearings and locked rotor protection. The unit's average power consumption shall be 0.16 watts per l/s of airflow.

The unit shall be supplied with a length of flexible ducting, and all necessary connectors and fixings. The unit shall weigh less than 6kg and we recommend that the unit is suspended from the ceiling.

The unit shall be supplied with a purpose designed flame retardant polymer diffuser for efficient, directable air input. The diffuser design shall be optimised for use in areas where smoke detectors are fitted.

The unit shall include 5 programmable temperature control strategies, 6 volume control settings and an optional high duty boost setting providing an airflow rate of 70 l/s for optimum performance and occupant comfort. All control/duty strategies shall be optimised for maximum occupant comfort.

The unit's "Intelligent Heat Recovery" shall be achieved via twin temperature sensors; one sensor integral to the unit to monitor loft temperatures and one sensor located in the living space. The twin sensors shall optimise energy performance accordingly. The sensor located in the living space shall also be capable of providing unit/filter status indication.

An internal monitor shall record the unit's operational time.

The unit shall be offered with a 5 year warranty.

For information on reducing radon egress, it is suggested that the details given in Positive pressurisation: a guide to radon remedial measures in existing dwellings may be considered.