

## POSITIVE INPUT VENTILATION

129

FAN TYPE	FAN LOCATION	MAX PERFORMANCE	PAGE
DRIMASTER	LOFT	10 - 70l/s	130
DRIMASTER 2000	LOFT	10 - 70l/s	134
DRIMASTER 365	LOFT	10 - 70l/s	138
DRIMASTER HEAT	LOFT	10 - 70l/s	142
FLATMASTER	WALL	15 - 22l/s	148
FLATMASTER 2000	WALL	15 - 35l/s	152

## DRIMASTER - POSITIVE INPUT VENTILATION (PIV)

LOW COST WHOLE HOUSE VENTILATION THAT MEETS BUILDING REGULATIONS, SAVES ENERGY AND PREVENTS CONDENSATION.

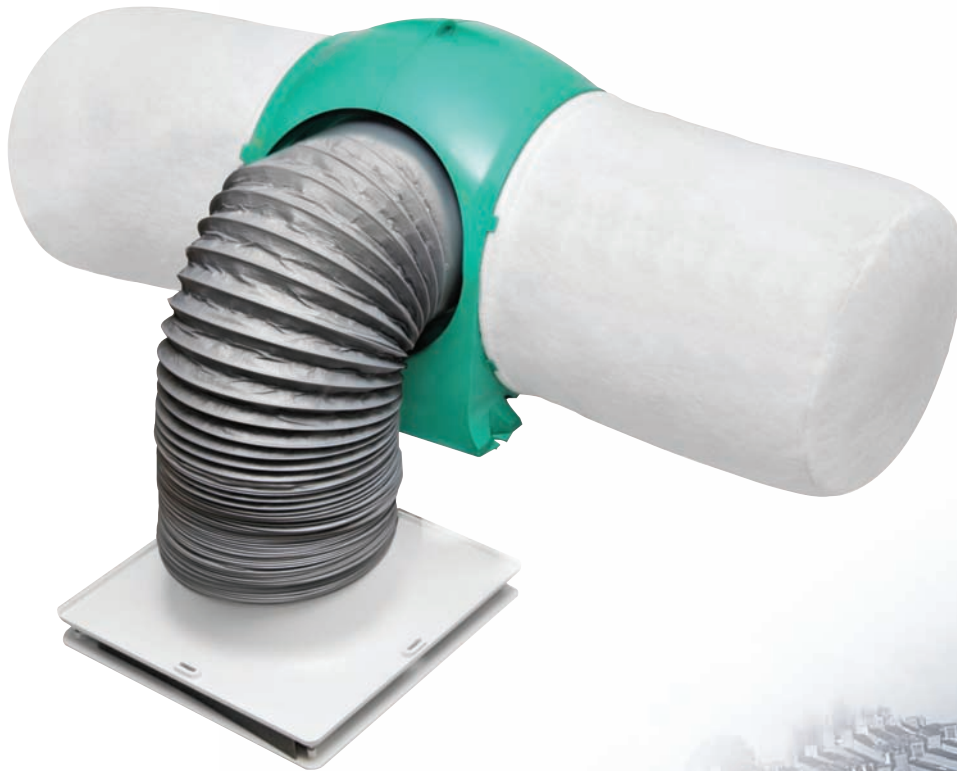

## BENEFITS

### EXTREMELY LOW POWER CONSUMPTION

Average approximately 0.16 watts / litre / second and solar gains up to 550kW / hr / year.

### EASY INSTALLATION & VERY LOW MAINTENANCE REQUIREMENT

Filter clean or replacement every 5 years.

### SIGNIFICANTLY IMPROVES INDOOR AIR QUALITY

Using positive input ventilation removes indoor air pollutants such as carbon monoxide and keeps out traffic fumes, pollen and outdoor pollutants.

### COMPLIES WITH THE BUILDING REGULATION VENTILATION REQUIREMENTS

Meets Part F&L England and Wales and contributes towards 'conservation of fuel and power'. (Please refer to BBA Certificate).

### RADON GAS CONTROL

Helps reduce and maintain radon gas levels.

### CREATES A HEALTHIER LIVING ENVIRONMENT

High efficiency G4 filters removes up to 95% dust particles.

### FIT & FORGET OPERATION

Fully automatic when airflow set on installation.

### FIRE DAMPER AND DIFFUSER FOR 3-STOREY ACCOMMODATION AVAILABLE

The diffuser is manufactured from aluminium and powder coated to an off white finish (RAL 9003). Product code Drimaster-3S.

### SYSTEM STANDBY MODE

For summer months when loft temperature exceeds 23°C.

### HEALTH

Clinically proven to help allergy and asthma sufferers.

### WARRANTY

5 year warranty for peace of mind.



## TYPICAL INSTALLATION

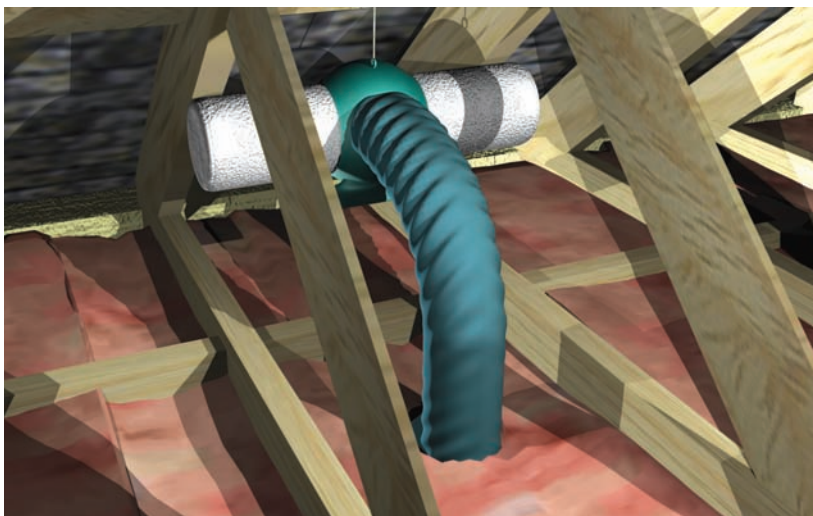

Ceiling diffuser.



DRIMASTER

The Drimaster provides whole home ventilation using the Positive Input Ventilation principle. Essentially the concept is to introduce fresh, filtered air into the dwelling at a continuous rate, encouraging movement of air from inside to outside. To achieve this, the unit is mounted in the loft space, drawing air through the filters and inputting it, at ceiling level, into the property.

The Drimaster units are fitted with an internal temperature sensor. This sensor continuously monitors the temperature in the loft, boosting the air volume when the loft temperature is above a set level (heat recovery mode).

If the loft temperature becomes excessive the unit will switch to standby mode (no airflow). Once installed, the airflow can be set to suit the house size and, if required, the way it responds to the temperature changes within.

AIR DIFFUSER WITH FIRE DAMPER

For use in stairwells of three storey properties, the optional powder-coated aluminium diffuser with 'Fireblock' provides 1 hour of fire resistance in accordance with BS476 Part 20 and ISO834.

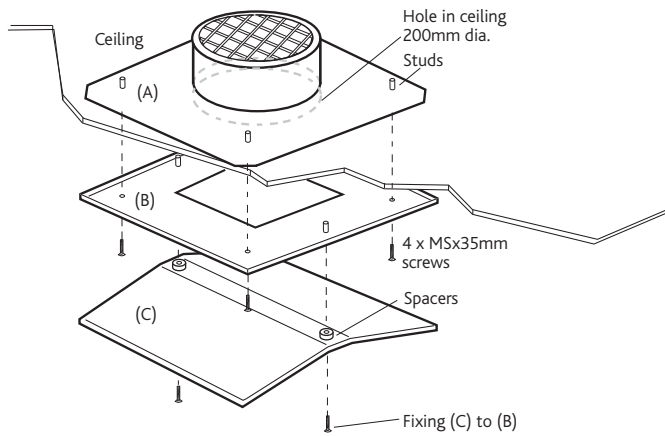

WIRING

The unit is supplied with a pre-wired power supply. This power supply unit has a metal bracket incorporating fixing holes, which should be used to fit the power supply to a suitable surface e.g. a wooden joist. The fan unit is also supplied with a fused spur. The 3 core mains cable from the power supply should be connected to a fixed wiring installation, via the isolator, via the spur, in accordance with current IEE wiring regulations.

Electrical details:-

- Voltage:** 240V 1ph 50Hz
- Consumption:** 1.6W(min) 15.3W(max)
- Fuse size:** 1 Amp

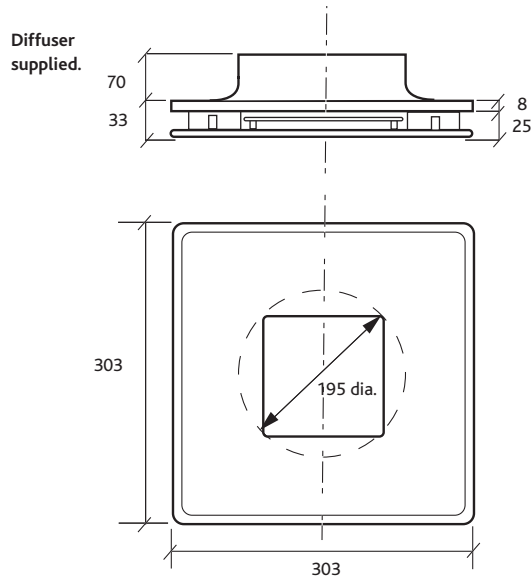

DIMENSIONS (MM) & WEIGHT DRIMASTER UNIT

Weight: 5.7kg

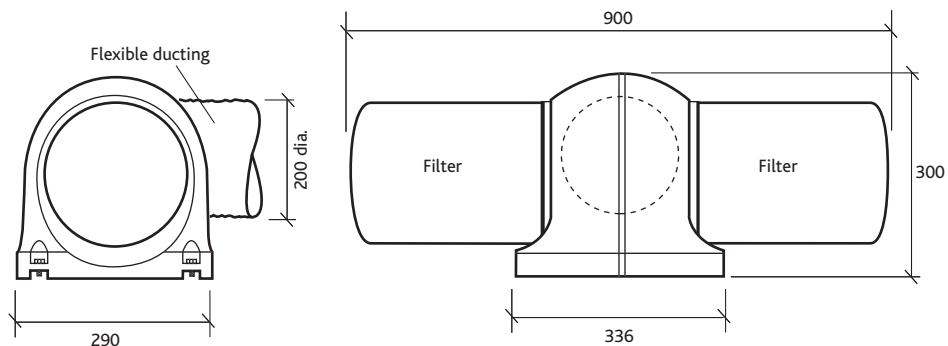

## CONSULTANTS SPECIFICATION

### FAN DESCRIPTION

Low energy positive input ventilation unit - for use in homes with a loft.

The unit shall be robustly constructed from flame retardant VO rated ABS polymer and the casing shall be of spherical pattern with a flat mounting base.

Flame retardant filters of G4 grade, surface area approx 0.47m<sup>2</sup> (with 5 year typical maintenance period) shall be fitted, which may be removed from the unit without the use of tools. The filters shall be arranged such as to prevent their obstruction in the loft space.

The unit shall incorporate a forward curved centrifugal impeller and high efficiency brushless DC motor fitted with sealed for life, self lubricating bearings and locked rotor protection. The unit's average power consumption shall be 0.16 watts per l/s of airflow.

The unit shall be supplied with a length of flexible ducting, and all necessary connectors and fixings.

The unit shall weigh less than 6kg and we recommend that the unit is suspended from the roof structure.

The unit shall be supplied with a purpose designed flame retardant polymer diffuser for efficient, directable air input. The diffuser design shall be optimised for use in areas where smoke detectors are fitted. The unit shall include 5 programmable temperature control strategies, 6 volume control settings and an optional high duty boost setting providing an airflow rate of 70l/s for optimum performance and occupant comfort.

The units "Fixed Temperature Heat Recovery" strategy shall be achieved via a sensor located in the unit and shall improve energy performance accordingly. An internal monitor shall record the unit's operational time.

The unit shall be offered with a 5 year warranty.

For information on reducing radon egress, it is suggested that the details given in Positive pressurisation: a guide to radon remedial measures in existing dwellings may be considered.

## DRIMASTER 2000 - POSITIVE INPUT VENTILATION (PIV)

LOW COST WHOLE HOUSE VENTILATION WITH INTELLIGENT HEAT RECOVERY THAT MEETS BUILDING REGULATIONS, SAVES ENERGY AND PREVENTS CONDENSATION.

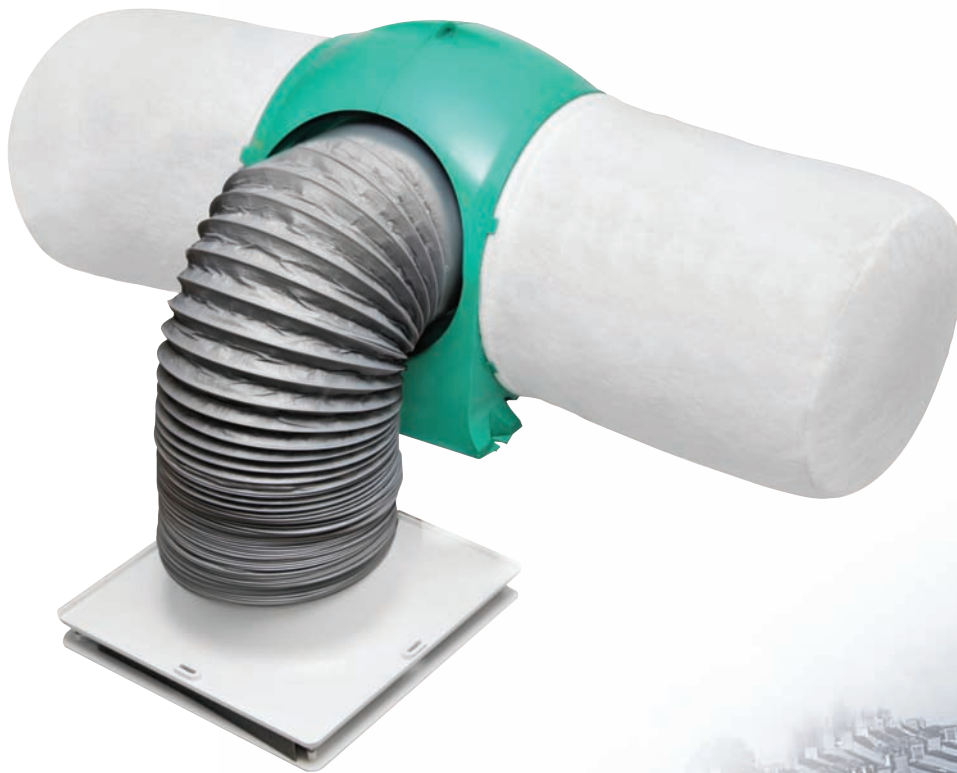

Sensor/Indicator

## BENEFITS

### EXTREMELY LOW POWER CONSUMPTION

Average approximately 0.16 watts / litre / second and solar gains up to 550kW / hr / year.

### EASY INSTALLATION & VERY LOW MAINTENANCE REQUIREMENT

Filter clean or replacement every 5 years.

### SIGNIFICANTLY IMPROVES INDOOR AIR QUALITY

Using positive input ventilation removes indoor air pollutants such as carbon monoxide and keeps out traffic fumes, pollen and outdoor pollutants.

### INTELLIGENT HEAT RECOVERY

Twin sensors optimise energy efficiency, adjusting settings to provide increased comfort.

### COMPLIES WITH THE BUILDING REGULATION VENTILATION REQUIREMENTS

Meets Part F&L England and Wales and contributes towards 'conservation of fuel and power'. (Please refer to BBA Certificate).

### CREATES A HEALTHIER LIVING ENVIRONMENT

High efficiency G4 filters removes up to 95% dust particles.

### FIT & FORGET OPERATION

Fully automatic when airflow set on installation.

### FIRE DAMPER AND DIFFUSER FOR 3-STOREY ACCOMMODATION AVAILABLE

The diffuser is manufactured from aluminium and powder coated to an off white finish (RAL 9003). Product code Drimaster-3S.

### SYSTEM STANDBY MODE

For summer months when loft temperature exceeds 23°C.

### HEALTH

Clinically proven to help allergy and asthma sufferers.

### OPTIONAL BOOST FACILITY

When additional ventilation is required i.e. cooking odours etc.

### WARRANTY

5 year warranty for peace of mind.

## INSTALLATION OPTIONS

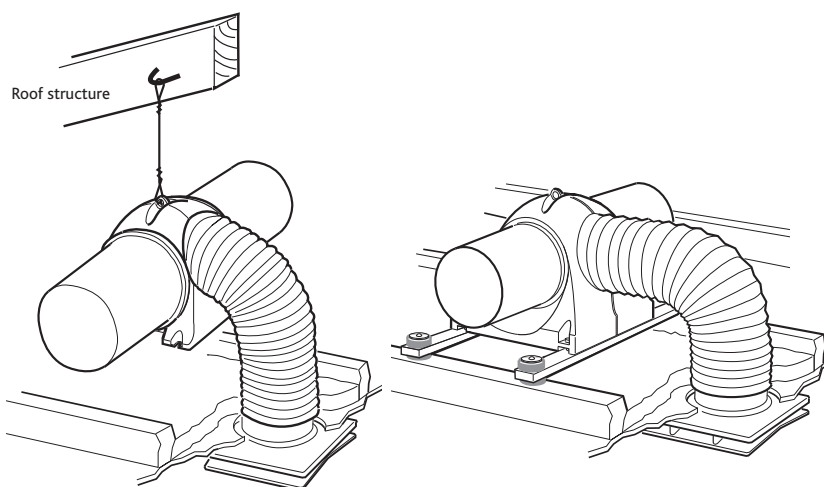

Standard method of fixing.

Optional method of fixing. (AV mounting kit onto roof joists).



Ceiling diffuser.



**DRIMASTER 2000**

The Drimaster 2000 provides whole home ventilation using the Positive Input Ventilation principle. Essentially the concept is to introduce fresh, filtered air into the dwelling at a continuous rate, encouraging movement of air from inside to outside. To achieve this, the unit is mounted in the loft space, drawing air through the filters and inputting it, at ceiling level, into the property.

**Siting the Remote Sensor**

The Remote Temperature Sensor incorporates a clip-in fixing bracket which can be removed for easy fitting to a suitable surface.

Select a suitable location for the sensor e.g. close to ceiling height in a bedroom or hallway BUT NOT WITHIN 3 METRES of the diffuser.



**AIR DIFFUSER WITH FIRE DAMPER**

For use in stairwells of three storey properties, the optional powder-coated aluminium diffuser with 'Fireblock' provides 1 hour of fire resistance in accordance with BS476 Part 20 and ISO834.

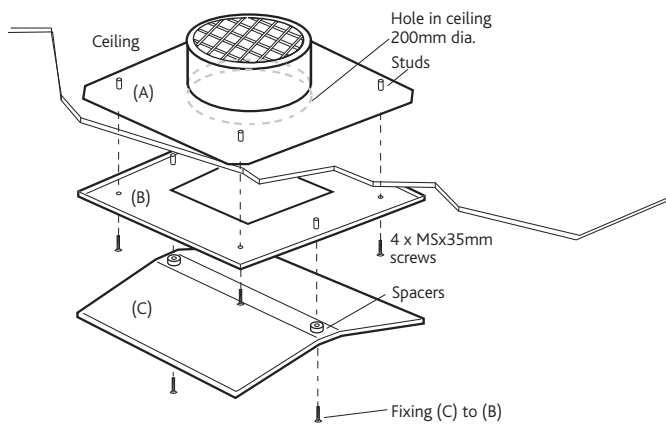

**WIRING**

The unit is supplied with a pre-wired power supply. This power supply unit has a metal bracket incorporating fixing holes, which should be used to fit the power supply to a suitable surface e.g. a wooden joist.

The fan unit is also supplied with a fused spur. The two core mains cable from the power supply should be connected to a fixed wiring installation, via the isolator, via the spur, in accordance with current IEE wiring regulations.

**Optional 'BOOST' facility**

The unit air volume can be manually boosted to maximum speed by wiring in a simple one way switch (Part No. 773532) into the wire supplying the sensor. By switching the unit to 'BOOST' all other functions are over-ridden.

**Electrical details:-**

- Voltage:** 240V 1ph 50Hz
- Consumption:** 1.6W(min) 15.3W(max)
- Fuse size:** 1 Amp

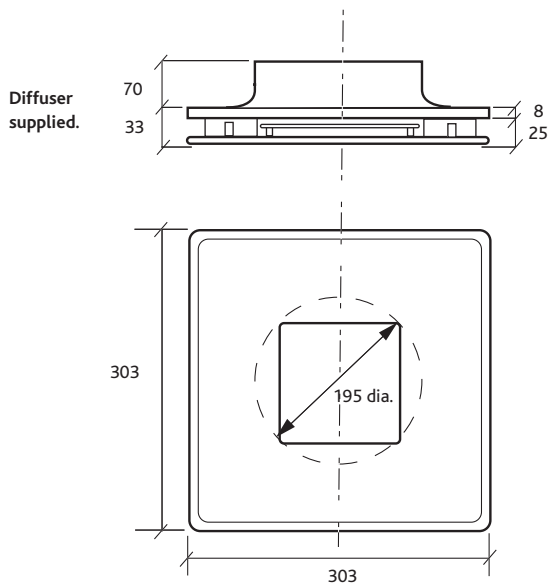

**DIMENSIONS (MM) & WEIGHT DRIMASTER 2000 UNIT**

**Weight: 5.7kg**

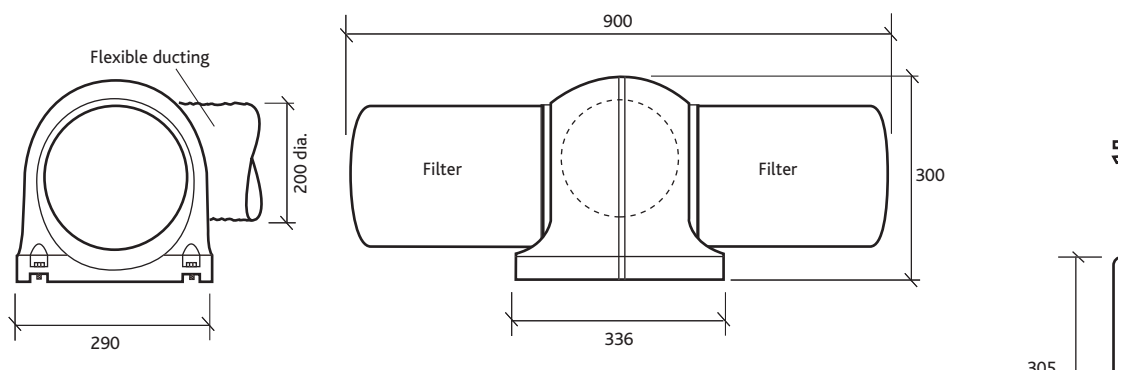

## CONSULTANTS SPECIFICATION

### FAN DESCRIPTION

Low energy positive input ventilation unit - for use in homes with a loft.

The unit shall be robustly constructed from flame retardant VO rated ABS polymer and the casing shall be of spherical pattern with a flat mounting base.

Flame retardant filters of G4 grade, surface area approx 0.47m<sup>2</sup> (with 5 year typical maintenance period) shall be fitted, which may be removed from the unit without the use of tools. The filters shall be arranged such as to prevent their obstruction in the loft space.

The unit shall incorporate a forward curved centrifugal impeller and high efficiency brushless DC motor fitted with sealed for life, self lubricating bearings and locked rotor protection. The unit's average power consumption shall be 0.16 watts per l/s of airflow.

The unit shall be supplied with a length of flexible ducting, and all necessary connectors and fixings. The unit shall weigh less than 6kg and we recommend that the unit is suspended from the ceiling.

The unit shall be supplied with a purpose designed flame retardant polymer diffuser for efficient, directable air input. The diffuser design shall be optimised for use in areas where smoke detectors are fitted.

The unit shall include 5 programmable temperature control strategies, 6 volume control settings and an optional high duty boost setting providing an airflow rate of 70 l/s for optimum performance and occupant comfort. All control/duty strategies shall be optimised for maximum occupant comfort.

The unit's "Intelligent Heat Recovery" shall be achieved via twin temperature sensors; one sensor integral to the unit to monitor loft temperatures and one sensor located in the living space. The twin sensors shall optimise energy performance accordingly. The sensor located in the living space shall also be capable of providing unit/filter status indication.

An internal monitor shall record the unit's operational time.

The unit shall be offered with a 5 year warranty.

For information on reducing radon egress, it is suggested that the details given in Positive pressurisation: a guide to radon remedial measures in existing dwellings may be considered.

## DRIMASTER 365 - POSITIVE INPUT VENTILATION (PIV)

A UNIQUE, LOW ENERGY, ALL YEAR ROUND VENTILATION UNIT.



## BENEFITS

### EXTREMELY LOW POWER CONSUMPTION

Average approximately 0.16 watts / litre / second and solar gains up to 550kW / hr / year.

### EASY INSTALLATION & VERY LOW MAINTENANCE REQUIREMENT

Filter clean or replacement every 5 years.

### SIGNIFICANTLY IMPROVES INDOOR AIR QUALITY

Using positive input ventilation removes indoor air pollutants such as carbon monoxide and keeps out traffic fumes, pollen and outdoor pollutants.

### INTELLIGENT HEAT RECOVERY

Twin sensors optimise energy efficiency, adjusting settings to provide increased comfort.

### COMPLIES WITH THE BUILDING REGULATION VENTILATION REQUIREMENTS

Meets Part F&L England and Wales and contributes towards 'conservation of fuel and power'. (Please refer to BBA Certificate).

### RADON GAS CONTROL

Helps reduce and maintain radon gas levels.

### CREATES A HEALTHIER LIVING ENVIRONMENT

High efficiency G4 filters removes up to 95% dust particles.

### FIT & FORGET OPERATION

Fully automatic when airflow set on installation.

### FIRE DAMPER AND DIFFUSER FOR 3-STORY ACCOMMODATION AVAILABLE

The diffuser is manufactured from aluminium and powder coated to an off white finish (RAL 9003). Product code Drimaster-3S.

### HEALTH

Clinically proven to help allergy and asthma sufferers.

### SECURITY

Allows occupants to keep windows closed for added security and reduce noise levels.

### OPTIONAL BOOST FACILITY

When additional ventilation is required i.e. cooking odours etc.

### OPTIONAL HEATER FACILITY

To provide additional heat to the incoming air if required i.e. during very cold weather.

### WARRANTY

5 year warranty for peace of mind.

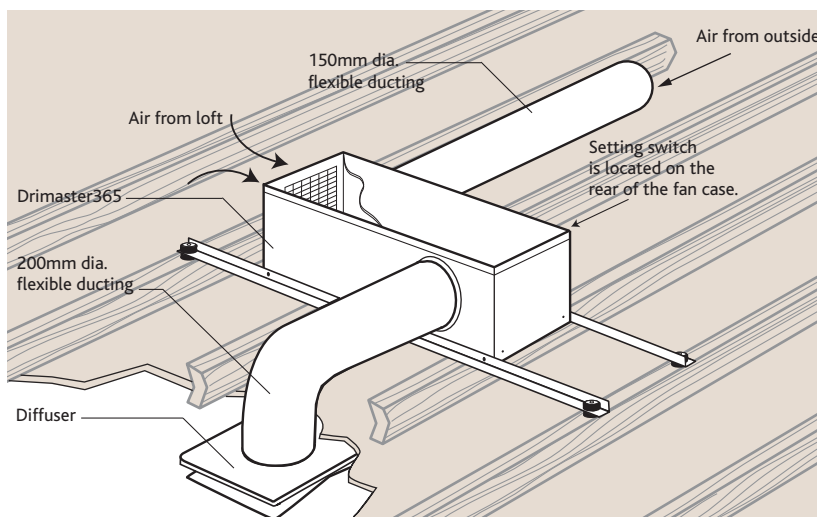
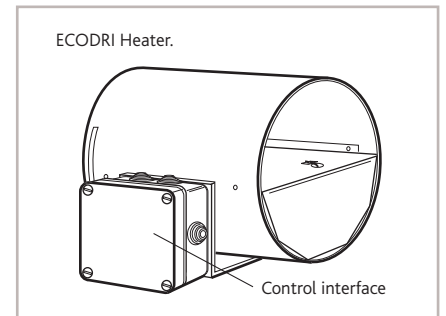

Unit mounted on roof joists using two "L" shape metal brackets and AV mounts supplied with unit.



Remote Sensor.



G4 Filter.



Boost Switch.



Ceiling Diffuser.

**DRIMASTER365**

Drimaster365 is a unique low energy, loft mounted Positive Input Ventilation unit providing whole home ventilation all year round. The unit is totally automatic and intelligently decides what location to supply the air from. It utilises the solar gain within the loft during the colder months subsequently, overcomes excessive solar gains during the warmer months.

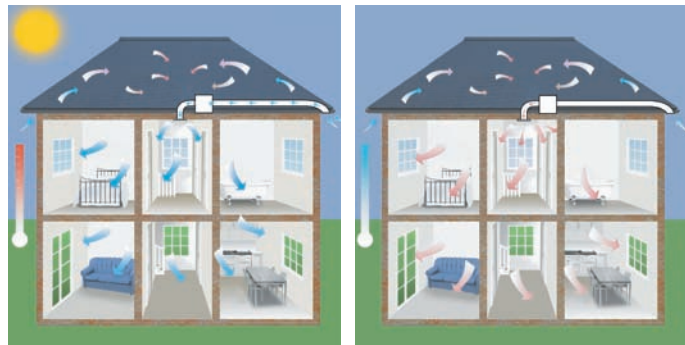

**SUMMER** - If the loft temperature is above 24°C air is drawn directly from outside, to provide background ventilation. In addition a boost switch is supplied to increase airflow when required.

**WINTER** - During the colder months tempered air is drawn from the loft space taking advantage of solar gain combined with the heat conducted through the ceiling of the home.

**THE BOOST SWITCH**

Drimaster365 air volumes can be boosted to obtain maximum ventilation by the operation of a boost switch which is supplied with the unit. By switching the unit to boost all other settings are over-ridden.

**INSTALLATION KITS FOR DRIMASTER365**

Please note: Full details of the installation materials supplied with the unit, and optional installation materials, not supplied with the unit, which can be purchased separately from Nuaire are listed in the installation manual, leaflet number 671429.

**\*Note: 3 storey properties must be fitted with an aluminium diffuser.**

**DIMENSIONS (MM)**

Drimaster365 unit.

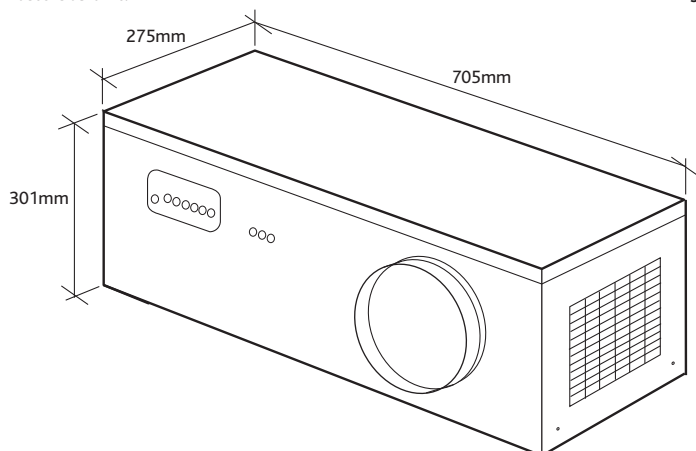

**WIRING**

Please note: the electrical connection of the unit must be carried out by a qualified electrician.

**Electrical details:-**

- Voltage:** 240V 1ph 50Hz
- Consumption:** 2W (min) 24W (max)
- Fuse rating:** 3 Amp

Note: This unit must be earthed.

The three core cable from the mains power supply should be connected to a fixed wiring installation, via a fused isolator, in accordance with current IEE wiring regulations.

**AIR DIFFUSER WITH FIRE DAMPER**

For use in stairwells of three storey properties, the optional powder-coated aluminium diffuser with 'Fireblock' provides 1 hour of fire resistance in accordance with BS476 Part 20 and ISO834.

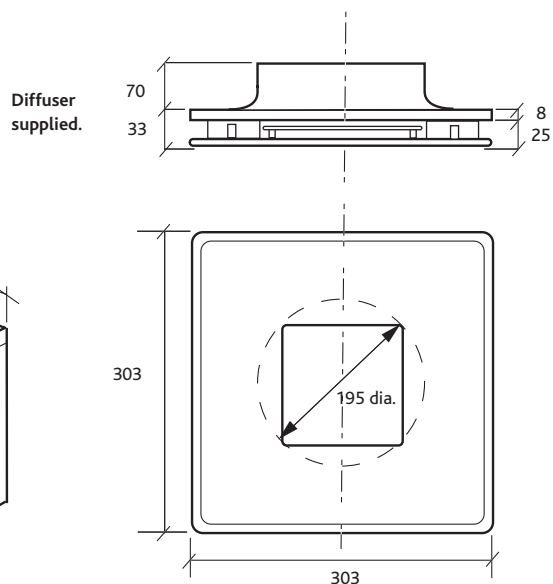
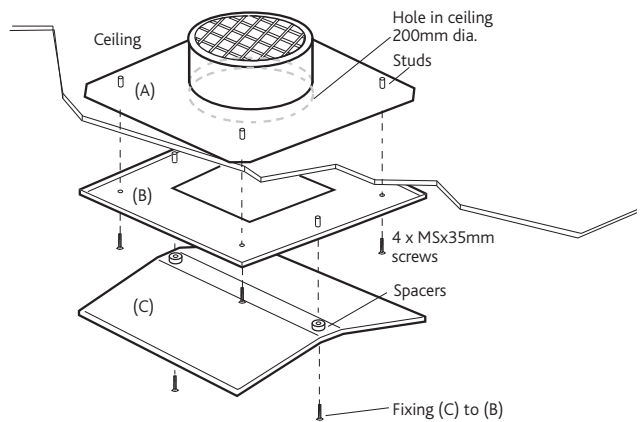

## CONSULTANTS SPECIFICATION

### FAN DESCRIPTION

Nuaire Drimaster365 ultra low energy positive input ventilation unit.

The unit casing shall be manufactured from thermally lined pre-painted steel.

The casing shall have an easily removable panel to allow access for maintenance.

The unit shall incorporate a filter of G4 grade with an area of approximately 0.47m<sup>2</sup>.

The unit shall incorporate a forward curved centrifugal impeller and high efficiency brushless DC motor fitted with sealed for life, self lubricating bearings and locked rotor protection.

The unit shall be supplied with a purpose designed polymer diffuser for efficient, directable air input using side blanking pieces supplied. The diffuser design shall minimise the accumulation of any condensate run off that may occur in the event of power to the unit being switched off.

The ducting between the unit and the diffuser is supplied with unit.

The unit shall incorporate 6 volume control settings for maximum flexibility and occupant comfort. The unit is fully automatic. If the loft temperature is below 24°C then the unit will draw fresh air from the loft. If the loft temperature is above 24°C then cool fresh air will be drawn from outside the dwelling.

The unit shall incorporate two air inlets, one draws air from the loft, the other from outside via a 150mm dia. spigot.

The unit can be boosted to obtain maximum ventilation by the operation of a boost switch (supplied).

An internal monitor shall record the unit's operational time.

The unit shall be offered with a 5 year warranty.

For information on reducing radon egress, it is suggested that the details given in Positive pressurisation: a guide to radon remedial measures in existing dwellings may be considered.

## DRIMASTER HEAT (PIV)

INCORPORATES AN INTEGRAL HEATER WHICH CAN BE SET TO PROVIDE ADDITIONAL HEATING OF THE INCOMING AIR IF REQUIRED.

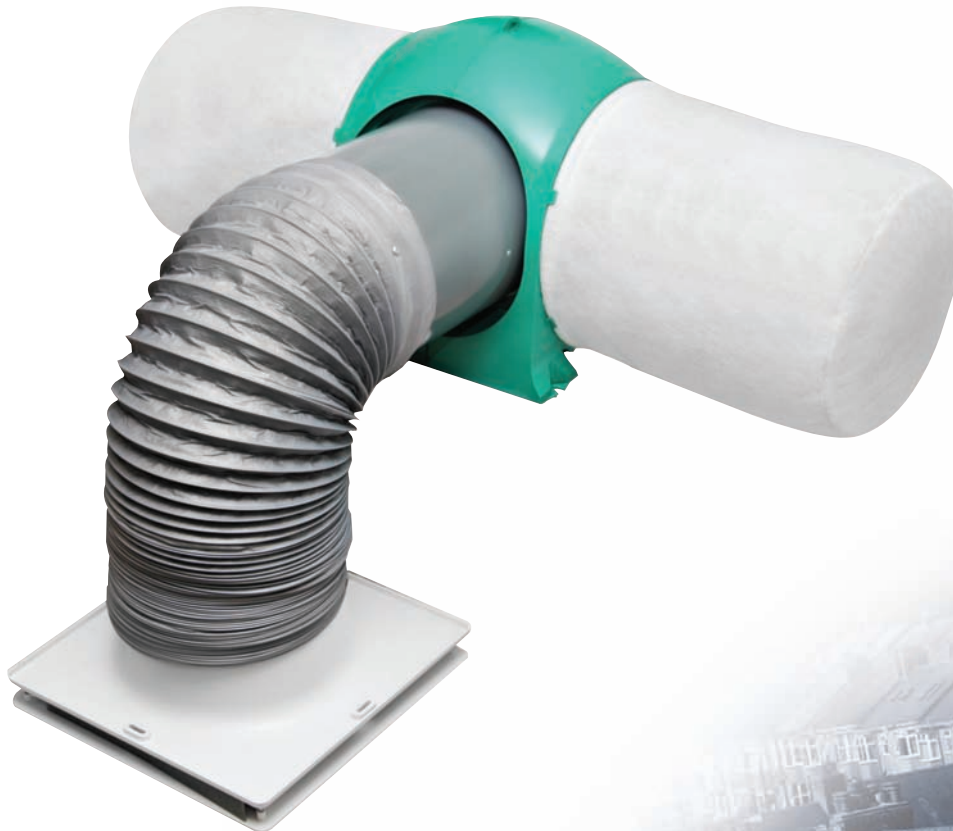

## BENEFITS

### INTEGRAL HEATER

To provide additional heating of the incoming air if required e.g. during very cold weather. The heater can be used to distribute filtered, warmed air throughout the property.

### EASY INSTALLATION & VERY LOW MAINTENANCE REQUIREMENT

Filter clean or replacement every 5 years.

### SIGNIFICANTLY IMPROVES INDOOR AIR QUALITY

Using positive input ventilation removes indoor air pollutants such as carbon monoxide and keeps out traffic fumes, pollen and outdoor pollutants.

### COMPLIES WITH THE BUILDING REGULATION REQUIREMENTS

Meets Part F&L England and Wales and contributes towards 'conservation of fuel and power'.

### INTELLIGENT HEAT RECOVERY

Twin sensors optimise energy efficiency, adjusting settings to provide increased comfort.

### RADON GAS CONTROL

Helps reduce and maintain radon gas levels.

### CREATES A HEALTHIER LIVING ENVIRONMENT

High efficiency G4 filters removes up to 95% dust particles.

### FIT & FORGET OPERATION

Fully automatic when airflow set on installation.

### FIRE DAMPER AND DIFFUSER FOR 3-STOREY ACCOMMODATION AVAILABLE

The diffuser is manufactured from aluminium and powder coated to an off white finish (RAL 9003). Product code Drimaster-3S.

### SYSTEM STANDBY MODE

For summer months when loft temperature exceeds 23°C.

### HEALTH

Clinically proven to help allergy and asthma sufferers.

### WARRANTY

5 year warranty for peace of mind.

### INSTALLATION OPTIONS

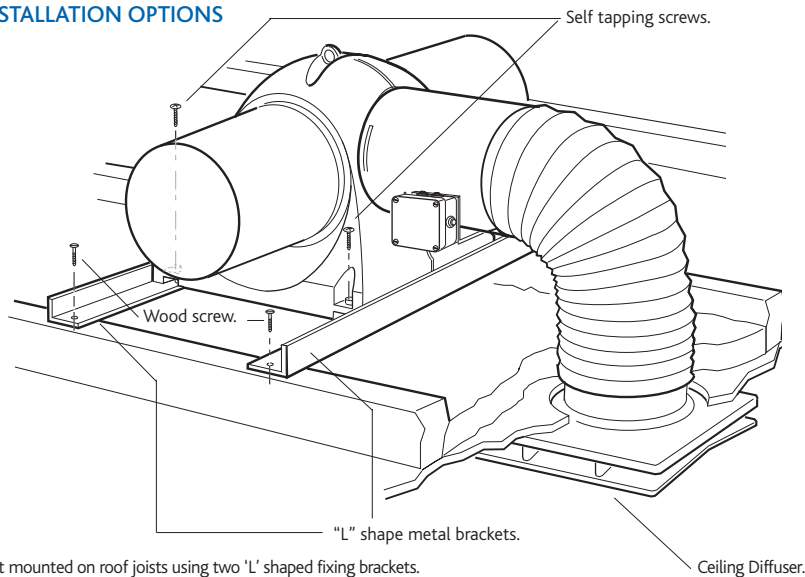

### Ceiling diffuser.



**DRIMASTER HEAT - HOW THE SYSTEM WORKS**

The Drimaster-Heat provides whole home ventilation using the Positive Input Ventilation principle. Essentially the concept is to introduce fresh, filtered air into the dwelling at a continuous rate, encouraging movement of air from inside to outside. To achieve this, the unit is mounted in the loft space, drawing air through the filters and inputting it, at ceiling level, into the property. The Drimaster units are fitted with an internal temperature sensor. This sensor continuously monitors the temperature in the loft, boosting the air volume when the loft temperature is above a set level (heat recovery mode).

If the loft temperature becomes excessive the unit will switch to standby mode (no airflow). Once installed, the airflow can be set to suit the house size and, if required, the way it responds to the temperature changes within.



The Drimaster-Heat unit incorporates an integral heater which can be set to provide additional heating of the incoming air if required e.g. during very cold weather. The heater can be used to distribute filtered, warmed air throughout the property.

**DRIMASTER HEAT AIR DIFFUSER**

The unit shall be supplied with a purpose designed polymer diffuser which provides efficient, directional controllable air supply using side blanking pieces supplied. The diffuser design shall minimise the accumulation of any condensate run off that may occur in the event of power to the unit being switched off. The diffuser shall have been independently assessed for behaviour in relation to fire and adjacent smoke detectors.

**AIR DIFFUSER WITH FIRE DAMPER**

For use in stairwells of three storey properties, the optional powder-coated aluminium diffuser with 'Fireblock' provides 1 hour of fire resistance in accordance with BS476 Part 20 and ISO834.

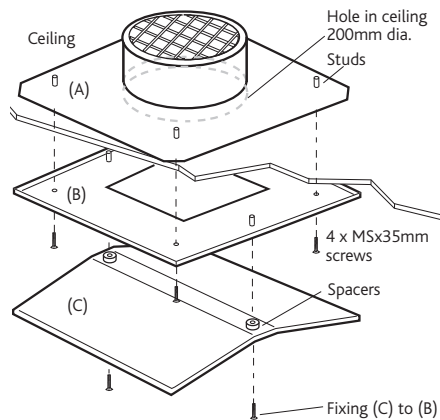

**Casing**



**Code description**

**DRIMASTER-HEAT**

DRIMASTER HEAT - DIMENSIONS (mm)

Drimaster-Heat Unit

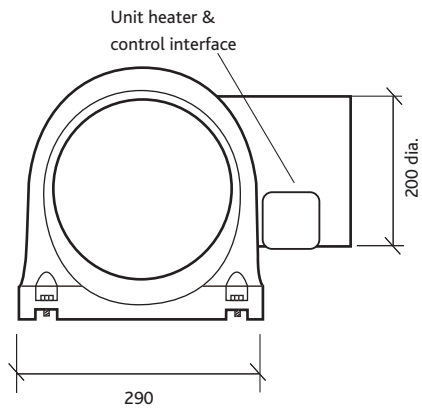
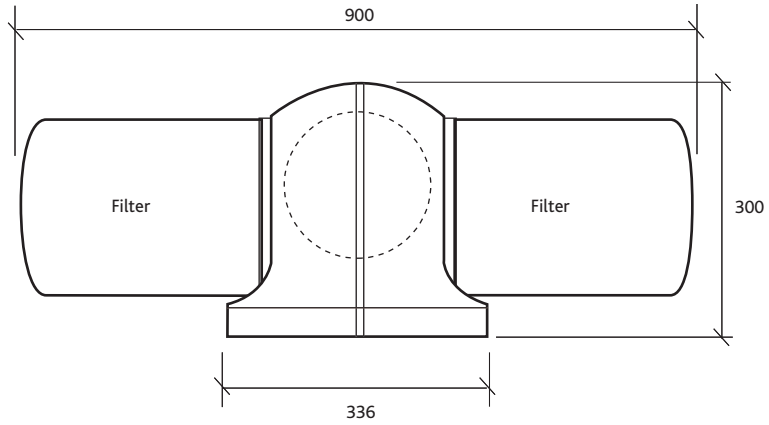

Diffuser supplied.

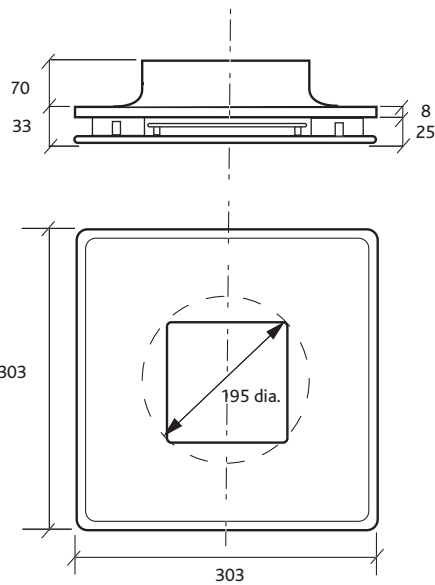

**ELECTRICAL CONNECTION**

Please note: the electrical connection of the unit must be carried out by a qualified electrician.

**Electrical details:**

Voltage:	240V 1ph 50Hz
Consumption:	Normal running: 1.6W (min) 15.3W (max), up to 500W with heater at full load.
Fuse rating:	3 Amp

The unit is supplied with a pre-wired power supply. This power supply unit has a metal bracket incorporating fixing holes, which should be used to fit the power supply to a suitable surface e.g. a wooden joist.

The fan unit is also supplied with a fused spur. The two core mains cable from the power supply should be connected to a fixed wiring installation, via the isolator, via the spur, in accordance with current IEE wiring regulations.

Typical wiring: Drimaster unit and heater can be wired up via 1 fuse spur, the fuse spur must be fitted with a 3 Amp fuse.

**ADJUSTING THE TARGET TEMPERATURE**

The occupier will normally require the heater to activate when the loft temperature falls below a predetermined point.

We recommend that the heater set point be set at 10°C. (see figure below).

Installer sets target temperature via the heater set point. The heater will fluctuate on and off to maintain this temperature.

**SPEED SETTINGS**

The unit has 6 Air Volume (speed) settings. The setting switch is located on the side of the unit. The LED's when illuminated, indicate the corresponding Air Volume from the unit.

As an example, for a one bedroom bungalow, the unit should be set onto the lowest setting (two lights on left). A five bedroom detached house would need to be set on the highest speed (all three LED's illuminated).

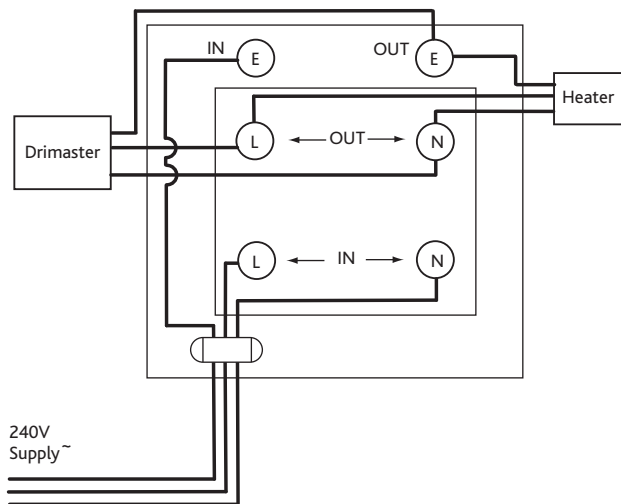

Ensure the fan is running before operating the heater.

If the heater should trip out the power should be isolated for several minutes to allow the unit to reset the thermal trip.

## CONSULTANTS SPECIFICATION

### SPECIFICATION

Low energy positive input ventilation unit - for use in homes with a loft. The unit shall be robustly constructed from flame retardant VO rated ABS polymer and the casing shall be of spherical pattern with a flat mounting base.

Flame retardant filters of G4 grade, surface area approx 0.47m<sup>2</sup> (with 5 year typical maintenance period) shall be fitted, which may be removed from the unit without the use of tools. The filters shall be arranged such as to prevent their obstruction in the loft space.

The unit shall incorporate a forward curved centrifugal impeller and high efficiency brushless DC motor fitted with sealed for life, self lubricating bearings and locked rotor protection. The unit's average power consumption shall be 0.16 watts per l/s of airflow (without heater element operational).

The unit shall be supplied with a length of flexible ducting, and all necessary connectors and fixings.

The unit will be supplied with brackets for fitting to joists.

The unit shall be supplied with a purpose designed flame retardant polymer diffuser for efficient, direct able air input. The diffuser design shall be optimised for use in areas where smoke detectors are fitted.

The unit shall include 5 programmable temperature control strategies, 6 volume control settings and an optional high duty boost setting providing an airflow rate of 70l/s for optimum performance and occupant comfort.

A heater section incorporating a 500w heating element shall be fitted to the fan unit. It shall be electronically controlled so as to minimise energy use.

A temperature sensor shall be fitted to the outlet of the heater and will control the output of heater in an attempt to maintain the set point. The set point will be adjustable between 2 and 20°C.

The units "Fixed Temperature Heat Recovery" strategy shall be achieved via a sensor located in the unit and shall improve energy performance accordingly. An internal monitor shall record the unit's operational time.

The unit shall be offered with a 5 year warranty.

For information on reducing radon egress, it is suggested that the details given in Positive pressurisation: a guide to radon remedial measures in existing dwellings may be considered.

## FLATMASTER - POSITIVE INPUT VENTILATION (PIV)

LOW COST VENTILATION FOR PROPERTIES WITH NO LOFT SPACE,  
THAT SAVES ENERGY AND PREVENTS CONDENSATION.



## BENEFITS

### EXTREMELY LOW POWER CONSUMPTION

As low as 3 Watts.

### EASY INSTALLATION & VERY LOW MAINTENANCE REQUIREMENT

Filter clean or replacement typically every 18 months.

### SIGNIFICANTLY IMPROVES INDOOR AIR QUALITY

Using positive input ventilation removes indoor air pollutants such as carbon monoxide and keeps out traffic fumes, pollen and outdoor pollutants.

### COMPLIES WITH THE BUILDING REGULATION VENTILATION REQUIREMENTS

Meets Part F&L England and Wales and contributes towards 'conservation of fuel and power'. (Please refer to BBA Certificate).

### RADON GAS CONTROL

Helps reduce and maintain radon gas levels.

### CREATES A HEALTHIER LIVING ENVIRONMENT

High efficiency filters removes up to 95% dust particles.

### FIT & FORGET OPERATION

Fully automatic when airflow set on installation.

### OPTIONAL HEATER FACILITY

To provide additional heat to the incoming air if required i.e. during very cold weather

### HOUR RUN MONITOR AVAILABLE

To record the units operational time

### WARRANTY

5 year warranty for peace of mind.



### TYPICAL INSTALLATION



Quick maintenance with easily cleaned filter.



Louvered vent.

**FLATMASTER**

Typical installations show unit with top discharge.

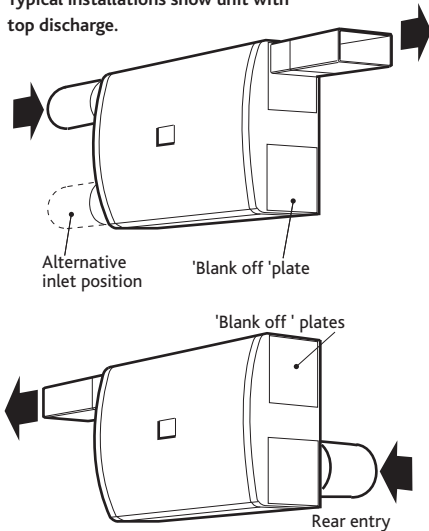

The unit is designed to take fresh air from outside, clean the air, warm it (if fitted with heater) and discharge it into the central hallway via a system of ducting supplied by the installer. The dwelling internal air discharge grille is usually installed at high level in a central location within the hallway, although discharging the air down the length of the hallway (away from the front door) should also prove acceptable. Unit performance may be enhanced if an existing heat source can warm the discharged air eg. by locating the discharge grille above a radiator.

enhanced if an existing heat source can warm the discharged air eg. by locating the discharge grille above a radiator.

**FLATMASTER- HEATER KIT OPTION**

Heater kit option - contains a blank insert with a cut out for the switch. This blank can be fitted into any appropriate opening but it is important that the switch is fitted so that the terminals are at the bottom.

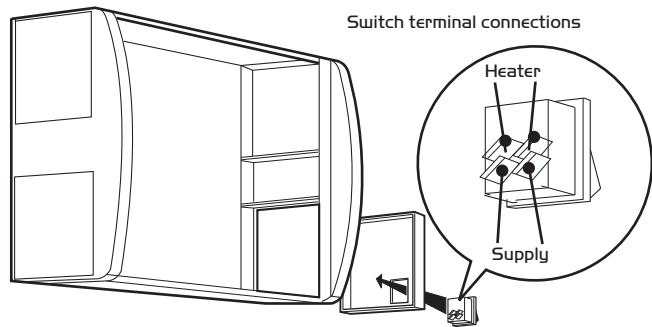

Note: Switch must be inserted into cut out in the blanking plate with the terminals to the bottom as shown.

**DIMENSIONS (MM) & WEIGHT FLATMASTER UNIT**

Weight: 6kg

100mm dia. or 121 x 60mm interchangeable spigots supplied with unit.

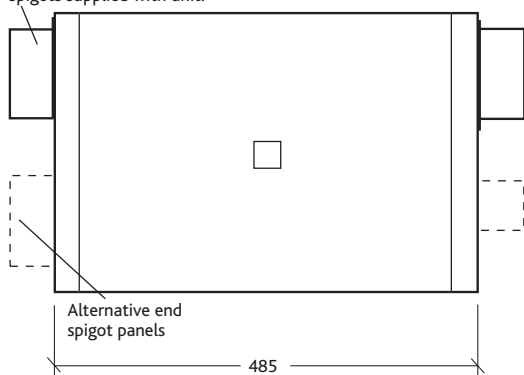

Alternative end spigot panels

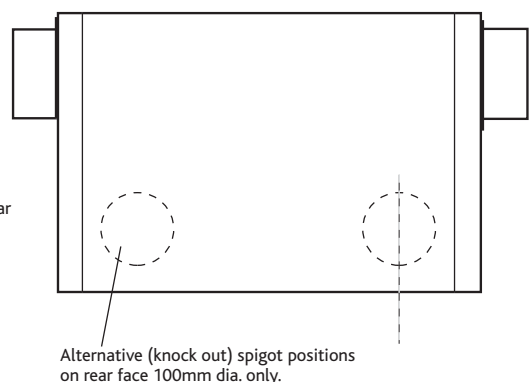
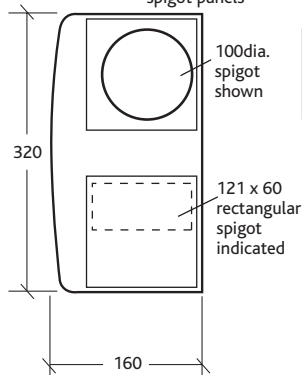

**WIRING**

Please note the electrical connections to the unit should be carried out by a qualified electrician.

With the PCB cover removed pull the PCB forward to gain access to earth post behind. Connect Earth cable to Earth Post next to the grommet hole. (If the heater option is required the wiring should be connected to the appropriate terminal on the PCB). Slide PCB into slot and connect the mains supply L and N to the terminal block.

**Electrical details:-**

Supply - 230V 1 phase 50Hz

**Power Consumption**  
(without heater option)

**Speed 1 - 5 Watts**

**Speed 2 - 8 Watts**

**Speed 3 - 13 Watts**

**Optional Heater - 300 Watts.**

The unit should be wired in accordance with current IEE regulations.

**Heater option wiring for general application.**

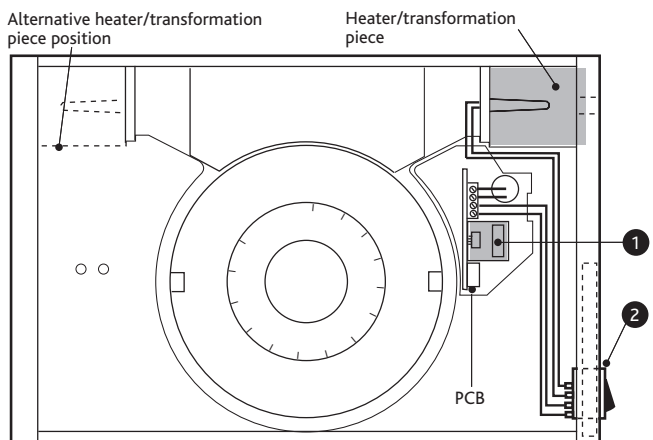

1 Optional plug-in 'hour run monitor' (records number of hours run) order code: FLAT-HRM.

2 Neon switch plate used for all general applications (except bathroom) see below. The electrical supply for the heater is taken from the PCB terminal block and connected the two lower tags on the neon switch. The upper pair of tags on the neon accept the heater leads.

## CONSULTANTS SPECIFICATION

### FAN DESCRIPTION

The attractively designed unit casing shall be manufactured from easy to clean flame retardant V0 rated ABS polymer and thermally insulated pre-coated mild steel. A washable flame retardant filter of G3 grade (with 1 - 2 year typical maintenance period) shall be fitted which may be accessed via the easily removable front cover.

The unit shall incorporate an injection moulded radial bladed centrifugal impeller. The impeller shall be driven by a high efficiency, reversible brushless DC motor fitted with sealed, self lubricating bearings and locked rotor protection.

The unit shall have a maximum power consumption of 0.45w/l/s of airflow. The unit shall be highly adaptable for ease of installation allowing circular or rectangular duct connections and for air entry from the side or rear of the case at high or low level.

A selection of spigots enabling connection to 100mm circular or 121x60mm rectangular distribution ductwork without the use of transformation sections shall be provided. The unit shall provide 3 volume control settings. Ducting and grilles shall be supplied separately.

The unit shall be suitable for the incorporation of an optional electric air-tempering heater as a plug in kit (Code: FLAT-HEATER). The unit shall be suitable for the incorporation of an optional plug in internal monitor which shall record the units operational time (Code: FLAT-HRM).

The unit shall be offered with a 5 year warranty.

## FLATMASTER 2000 - POSITIVE INPUT VENTILATION (PIV)

LOW COST VENTILATION WITH INTEGRAL HEATER FOR PROPERTIES  
WITH NO LOFT SPACE.



## BENEFITS

### EXTREMELY LOW POWER CONSUMPTION

As low as 5 Watts.

### EASY INSTALLATION & VERY LOW MAINTENANCE REQUIREMENT

Filter clean or replacement typically every 18 months.

### SIGNIFICANTLY IMPROVES INDOOR AIR QUALITY

Using positive input ventilation removes indoor air pollutants such as carbon monoxide and keeps out traffic fumes, pollen and outdoor pollutants.

### COMPLIES WITH THE BUILDING REGULATION VENTILATION REQUIREMENTS

Meets Part F&L England and Wales and contributes towards 'conservation of fuel and power'. (Please refer to BBA Certificate).

### RADON GAS CONTROL

Helps reduce and maintain radon gas levels.

### CREATES A HEALTHIER LIVING ENVIRONMENT

High efficiency filters removes up to 95% dust particles.

### FIT & FORGET OPERATION

Fully automatic when airflow set on installation

### INTEGRAL HEATER

To provide additional heating of the incoming air if required e.g. during very cold weather. The heater can be used to distribute filtered, warmed air throughout the property.

### MANUAL BOOST SWITCH PROVIDED

When additional ventilation is required i.e. cooking odours.

### WARRANTY

5 year warranty for peace of mind.



### TYPICAL INSTALLATION

#### Side input installation (view from side).

Input grille (louvres slant downwards)

100mm dia/121x60mm rectangular ducting (note input side kept as short as possible)

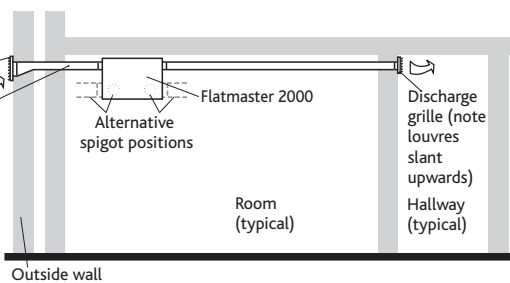

#### Rear input installation (view from above).

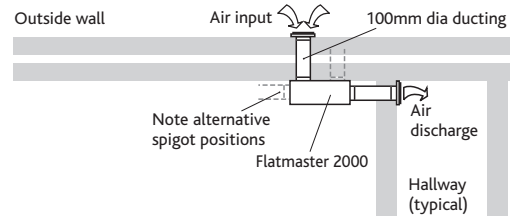

Remote boost switch.



Thermostatically controlled heater.

**FLATMASTER 2000**

The unit is designed to take fresh air from outside, clean the air, warm it (if fitted with heater) and discharge it into the central hallway via a system of ducting supplied by the installer. The dwelling internal air discharge grille is usually installed at high level in a central location within the hallway, although discharging the air down the length of the hallway (away from the front door) should also prove acceptable. Unit performance may be enhanced if an existing heat source can warm the discharged air eg. by locating the discharge grille above a radiator.

**Additional heat when required**

If additional heating of the incoming air is required e.g. during very cold weather, the integral heater can be used to distribute filtered, warmed air throughout the property.

Typical installations show unit with top discharge.

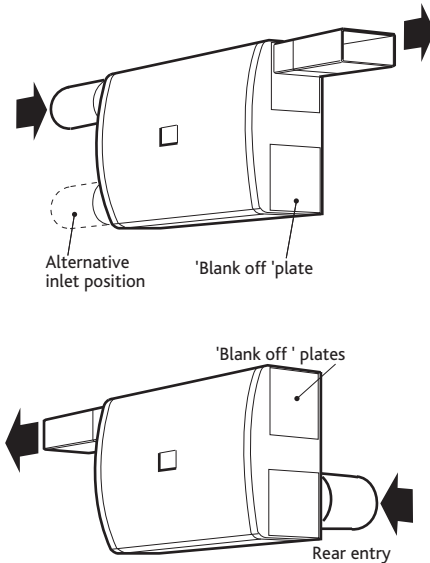

**SETTING UP THE CORRECT AIRFLOW DIRECTION**

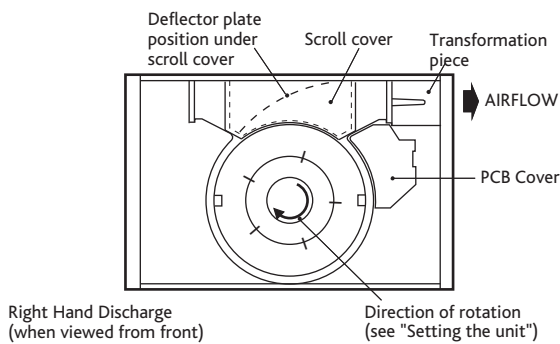
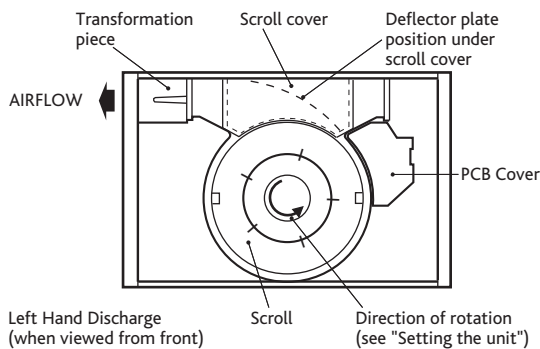

**Fitting the deflector plate**

Fit deflector plate into scroll cover as shown below. Once fitted the assembly can be slotted into the scroll and clipped firmly in place.

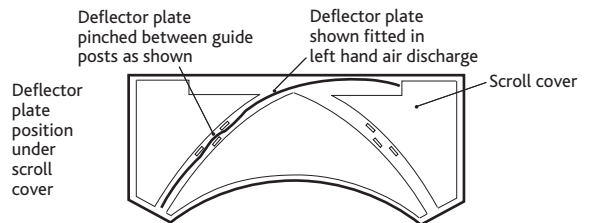

Deflector plate shown fitted for left hand air discharge (viewed from inside).

**Transformation Piece**

This should be on the appropriate scroll outlet. The transformation piece should be fitted into the chosen outlet spigot insert, prior to fitting.

Note: If the round spigot is used as an outlet, the 115 x 55mm clear blanking plate will need to be fitted (as shown). This plate should be prevented from movement by the use of silicone sealant.

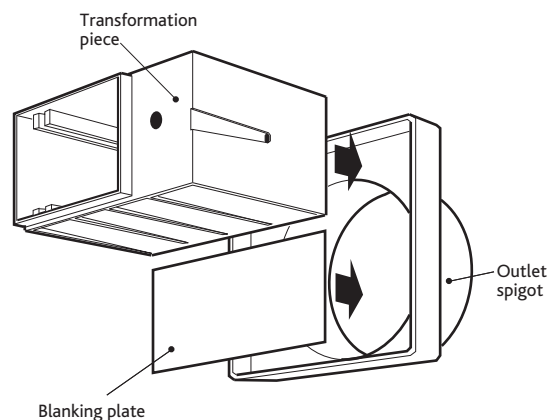

## WIRING

Please note the electrical connections to the unit should be carried out by a qualified electrician.

With the PCB cover removed pull the PCB forward to gain access to earth post behind. Connect Earth cable to Earth Post next to the grommet hole. (If the heater option is required the wiring should be connected to the appropriate terminal on the PCB).

Slide PCB into slot and connect the mains supply L and N to the terminal block.

### Electrical details:-

Supply - 230V 1 phase 50Hz

## DIMENSIONS (MM) & WEIGHT FLATMASTER 2000 UNIT

Weight: 4kg

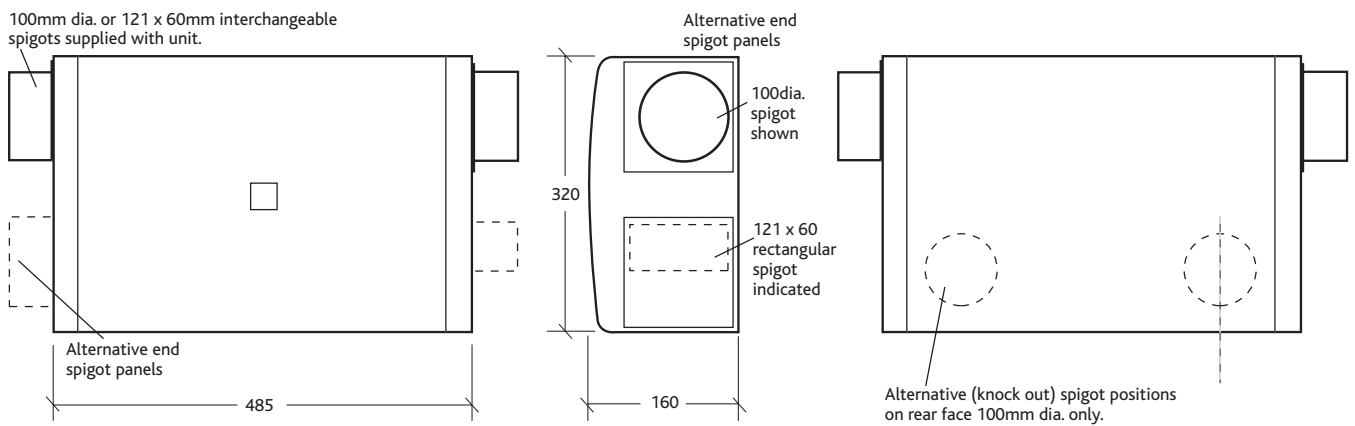

## CONSULTANTS SPECIFICATION

### FAN DESCRIPTION

The attractively designed unit casing shall be manufactured from easy to clean flame retardant V0 rated ABS polymer and thermally insulated pre-coated mild steel. A washable flame retardant filter of G3 grade (with 1 - 2 year typical maintenance period) shall be fitted which may be accessed via the easily removable front cover.

The unit shall incorporate an injection moulded radial bladed centrifugal impeller. The impeller shall be driven by a high efficiency, reversible brushless DC motor fitted with sealed, self lubricating bearings and locked rotor protection.

The unit shall have a maximum power consumption of 1.4 w/l/s of airflow. The unit shall be highly adaptable for ease of installation allowing circular or rectangular duct connections and for air entry from the side or rear of the case at high or low level.

A selection of spigots enabling connection to 100mm circular or 121x60mm rectangular distribution ductwork without the use of transformation sections shall be provided. The unit shall provide 3 volume control settings. Ducting and grilles shall be supplied separately.

The unit shall be suitable for the incorporation of an optional plug in internal monitor which shall record the units operational time (Code: FLAT-HRM).

The unit shall be offered with a 5 year warranty.