

MRXBOX90L - WHOLE HOUSE HEAT RECOVERY UNIT

90% EFFICIENT, SAP APPENDIX Q RECOGNISED
AND PASSIVE HOUSE CERTIFIED HEAT RECOVERY UNIT.



**Component
Suitable
for
Passive Houses**
Dr. Wolfgang Feist

valid only in combination with the certificate

BENEFITS

MEETS REGULATIONS

SAP Appendix Q recognised.
Certified by Passivhaus Institut.

HIGH EFFICIENCY

90% efficient, with DC motors using 50% less energy than traditional fans.

EXTREMELY LOW NOISE LEVELS

Acoustic insulation ensures the ideal solution for loft or cupboard installations.

GUARANTEED CONSTANT AIRFLOW

2 self adjusting fans provide constant fresh air.

HEALTHY ENVIRONMENT

Removes up to 95% of the dust from the atmosphere.

LOW AND EASY MAINTENANCE

Unit is fitted with filter indication display. Easy access to filters via "tool free" hinged door.

SIMPLE TO SET UP

Units have a display for easy installation.

AUTOMATIC SUMMER BYPASS AS STANDARD

Unit has summer bypass as standard. Unit continuously monitors the temperature inside and outside and will bypass the heat exchanger when appropriate.

MULTI OPTION CONTROLS AND SENSORS

Inbuilt controls that automatically adjust the fan speed to suit the individual systems pressure drop. Wide choice of controls including 3 speed trickle/boost and purge and optional wireless remote control.

WARRANTY

5 year warranty for peace of mind.



Removable filters.



Facia mounted control panel.



Speed selector switch (included).



Optional receiver.



Optional wireless remote control.

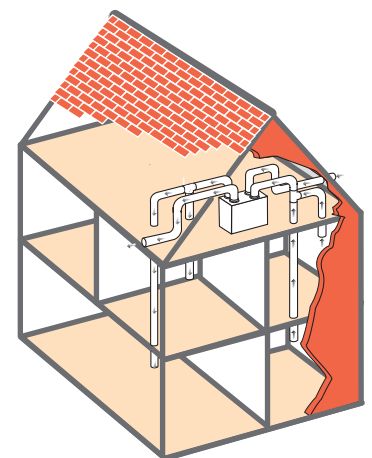

Typical installation with unit mounted in loft.

PERFORMANCE - MRXBOX90L

Air Performance of MRXBOX90L

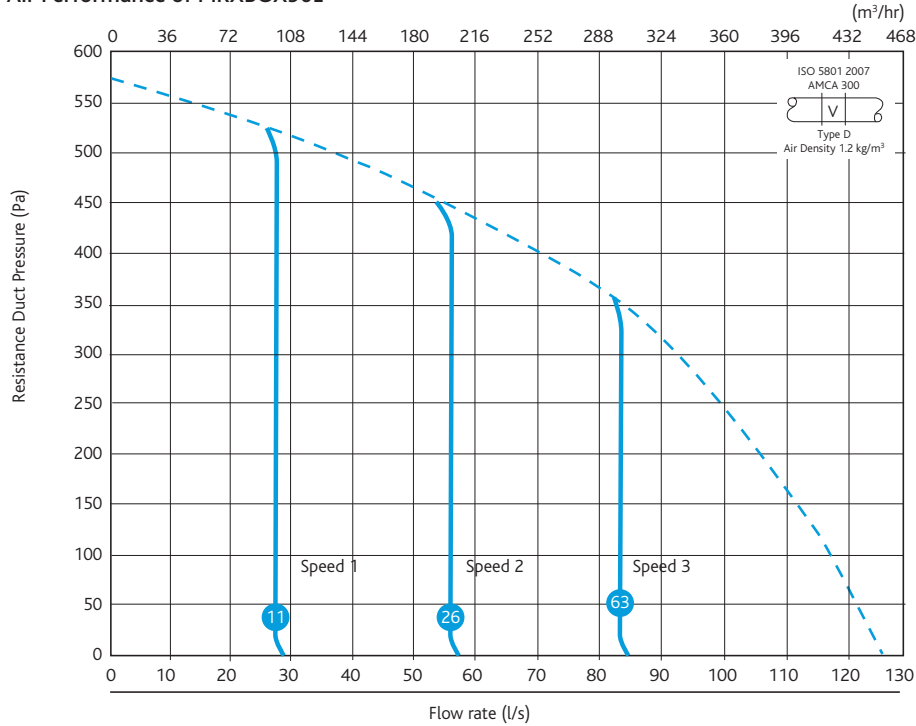

Casing

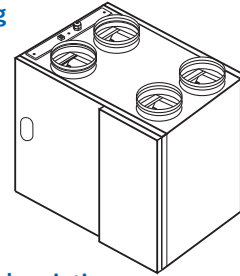

Code descriptions

MR - XBOX - 90 - L

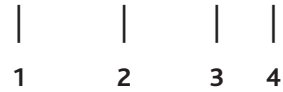

- 1. Multi-room Supply and extract heat recovery
- 2. Range
- 3. Efficiency
- 4. Size

Note: Speeds 1, 2 and 3 are factory default settings and can be adjusted to suit individual requirements.

No. = Power consumption.

MRXBOX90L

ELECTRICAL, SOUND & WEIGHT

Speed	Code	Phase	Total motor power watts	Full load current amps		Induct Sound Power Levels dB re 1pW								Breakout dBA @3m	Weight Kg
						63	125	250	500	1K	2K	4K	8K		
1	mrXbox90L	1	23	0.17	Breakout	45	38	36	32	26	18	7	9	33	40
					Supply	50	51	48	48	49	40	34	23		
					Extract	36	33	21	23	15	7	8	15		
2	mrXbox90L	1	67	0.45	Breakout	50	47	43	38	37	31	25	22	42	
					Supply	59	63	59	58	57	52	48	41		
					Extract	46	47	35	33	30	22	16	16		
3	mrXbox90L	1	175	1.16	Breakout	60	57	53	47	44	43	37	37	51	
					Supply	65	68	68	66	64	61	57	52		
					Extract	52	57	46	42	38	34	29	20		

Note: Speeds 1, 2 and 3 are factory default settings and can be adjusted to suit individual requirements.

DIMENSIONS (MM) MRXBOX90L

Dimensional references:

- 1 = spigot to dwelling. Supply (warmed fresh air).
- 2 = spigot to outside. Exhaust (cool stale air).
- 3 = spigot from dwelling. Extract (warm stale air).
- 4 = spigot from outside. Intake (cool fresh air).
- 5 = electric connections
- 6 = detail wall mounting (make sure to correctly place the rubber strip, washers and caps).

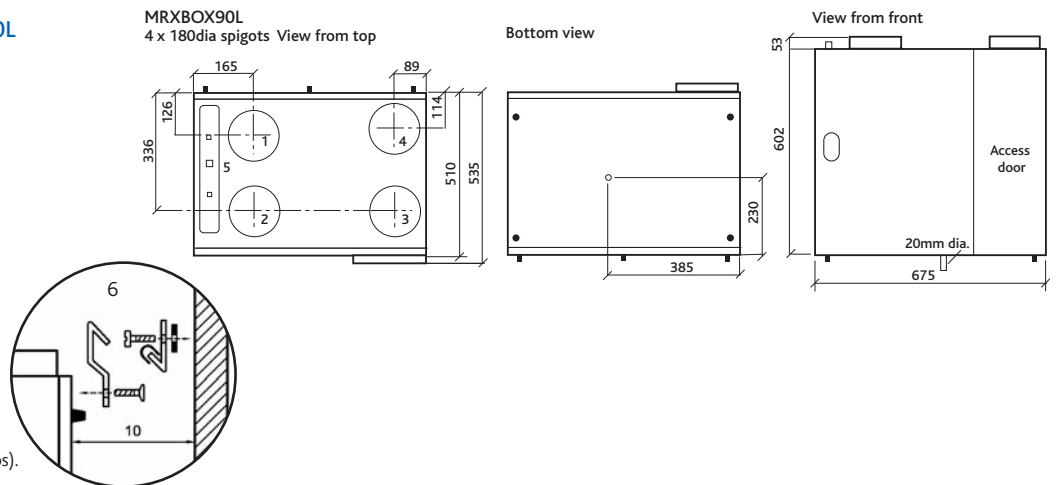

CONSULTANTS SPECIFICATION

OPERATION

The supply and extract ventilation unit shall be positioned as indicated on the drawings and shall be in accordance with the particular fan schedule in the specification.

The combined supply and extract with heat recovery unit, shall supply filtered fresh air to each of the habitable rooms and vitiated air shall be extracted from the wet areas e.g. bathroom, en-suite, w.c, kitchen, utility rooms, etc. The supply air shall be pre-heated by the warm extract air via the integrated counter-flow heat exchanger element. The extracted air shall also be filtered before it reaches the heat exchanger block.

The ventilation unit shall vary its speed and therefore the ventilation rate, as it receives signals from one of the following:

- Manual activation from 3 position switch.
 - Optional remote RF boost switch humidity sensor.
 - Optional externally interconnected sensors.
- } Via optional PCB.

When signals are received, the fan shall alter its speed to selectable, pre-set normal and boost rates.

The unit shall have the facility to commission the supply and extract fans via inbuilt minimum and maximum speed adjustment; the fans shall have infinitely variable speed control. Once the duty of the fans is set on the fascia mounted controller the unit shall automatically adjust its speed to maintain the air volume flow rate selected on a constant volume principle.

A summer bypass shall be included that shall allow fresh air to bypass the heat exchanger, when the incoming air temperature is at or above the designated "set point".

MRXBOX90L - UNIT SPECIFICATION

The unit shall be fully insulated providing excellent thermal and acoustic characteristics and shall be complete with a multi plate counter flow high efficiency heat exchanger block, with a thermal efficiency of up to 95%. The heat exchanger shall be protected by G4 grade filters on fresh air inlet and system extract. The heat exchanger and filters shall be accessible via fascia access panels, enabling quick and easy maintenance.

The unit shall have low energy, high efficiency d.c. fan/motor assemblies with sealed for life bearings, the impellers shall be forward curved centrifugal type. The motors shall be suitable of an ambient temperature of 40°C.

The unit shall have integral temperature sensors that shall monitor the incoming and extracted air temperatures to provide frost protection as well as controlling the summer bypass.

A fascia mounted control unit with microprocessor controls with LCD display enabling infinitely variable adjustment of the air volume.

The unit shall be supplied complete with an insulated condensate drip tray and 20mm drain connection.

The breakout noise level and power requirements shall be as detailed by the unit manufacturer and in accordance with the ventilation equipment schedule.

MRXBOX90L - CONTROL OPTIONS

All versions shall have a pre-wired and factory fitted, fascia mounted multi function control panel with LCD display providing the following:

- Integral speed control on supply and extract – 3 speeds available: -
 1. Low speed background ventilation control/set point.
 2. Medium speed ventilation control/set point, for day to day boost.
 3. High speed ventilation control/set point for summer boost.
- Constant volume facility to adjust for system pressure.
- Filter dirty & maintenance indication on fascia control.

The standard warranty for MRXBOX90 series shall be for 5 years.