

MARK TEN ROOF FANS

LOW DEPTH, VERTICAL DISCHARGE EXTRACT FAN
IDEAL FOR KITCHEN CANOPIES.



BENEFITS

UNOBTRUSIVE DESIGN

Extremely rigid low profile Aluminium manufacture easily accommodated on all building profiles.

EFFECTIVE FUME REMOVAL

High efficiency vertical discharge guarantees that fumes are quickly and efficiently removed from source.

ENERGY EFFICIENT

All 3 phase models are compatible with Ecosmart controls providing the most energy efficient and cost effective solution.

QUIETEST SYSTEM

Low noise, high performance mixed flow impeller together with matching silencers provide the perfect acoustic solution.

SYSTEM CONTROL

Ecosmart compatibility allows other fans/AHU's to interface directly with the Mark Ten.

AVOID HEAT LOSS

Integrated backdraught shutters, retained by magnetic latches, limits heat loss from the building when unit is off.

MAINTAINABILITY

Removable panels on sides and top allows for quick and effective maintenance.

PERFORMANCE OPTIONS

High performance mixed flow impeller with direct or belt drive options cater for all your systems pressure and sound requirements.

GUARANTEED VENTILATION

Standby motor option on belt drive version ensures ventilation in the event of fan failure.
Note: standby motor is unbelted.

ANCILLARIES

Full range of attenuators, mounting curbs, etc are available to complete your installation.

WARRANTY

Mark Ten has a 3 year warranty.
Ecosmart Mark Ten has a 5 year warranty.

TYPICAL INSTALLATION

When unit is not working, any rainfall etc. through the grilles is deflected by shutters and drained through casing vents.

Exhaust Airflow is through both grilles note the shutters are opened by air pressure when the unit is working.

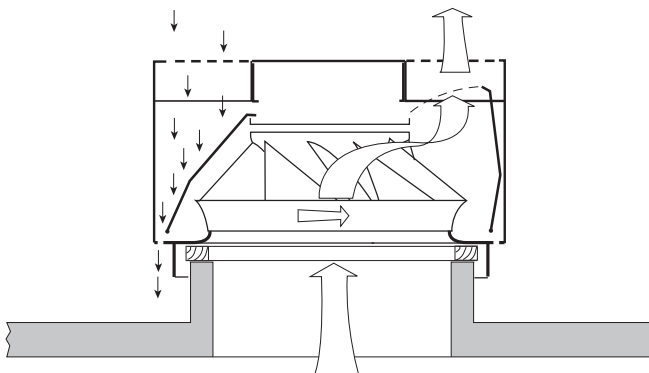

CONTROLS

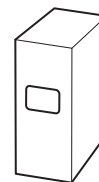

Ecosmart Control.

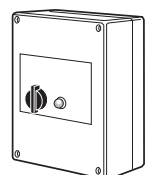

Electronic Speed Control.

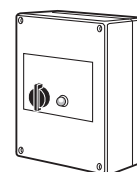

Transformer Speed Control.

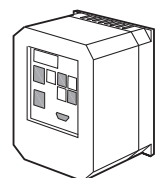

Inverter Speed Control.

PERFORMANCE - MARK TEN ROOF EXTRACT FANS

Mark Ten Roof Extract Units 1-8

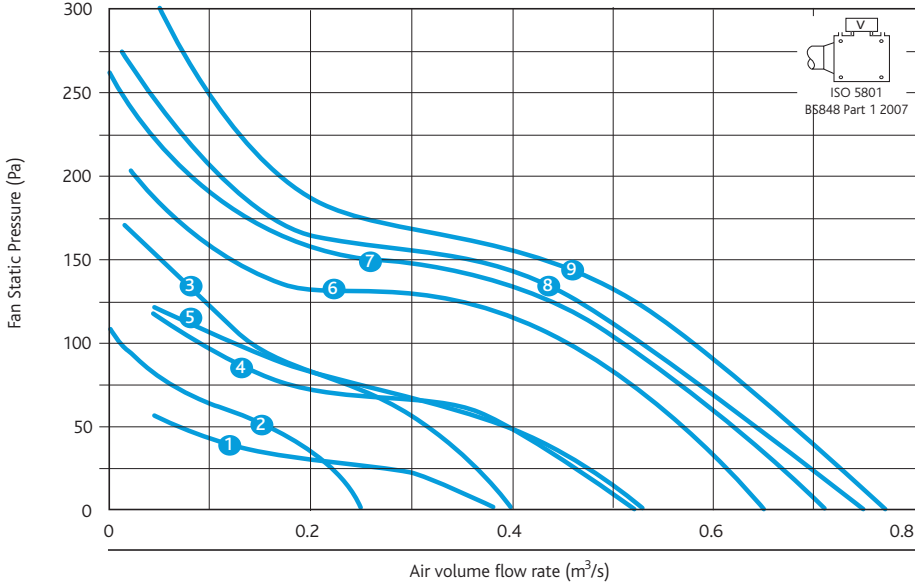

Mark Ten Roof Extract Units 9-15

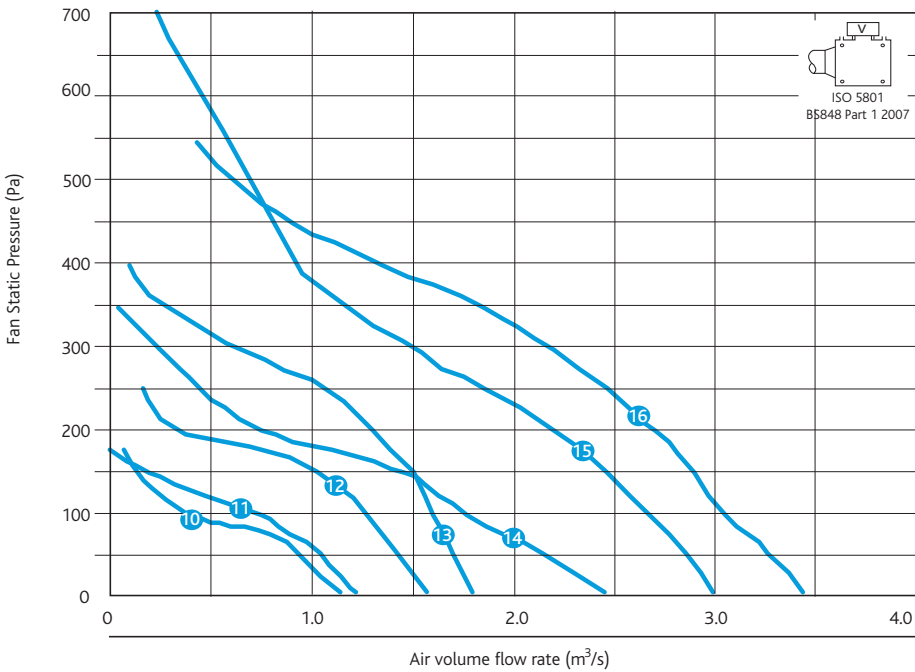

Casing

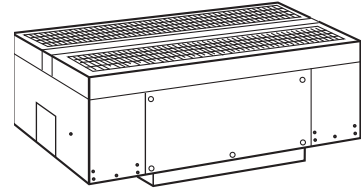

Code descriptions

315 MTD 1/2



- 1. Fan size
- 2. MTD = Direct Drive
MT = Belt Drive
Performance Reference
- 3. = Curb No./type
- 4. Phase
1 = Single phase,
2 = Three phase

Control descriptions

(ES) (B) (C)



- 1. ES = Full Ecosmart controls – BMS interfaces and commissioning.
Controls (as 2 & 3 below) full compatibility with Ecosmart sensors.
- 2. B = BMS interfaces 0-10V, volt free run and fail indication.
Commissioning/speed control built in.
Adjustable trickle and boost if required
- 3. C = Commissioning/speed control built in.
Adjustable trickle and boost if required.
All the above control options are pre-programmed with a soft start function.
The above control options are provided in a purpose made module, mounted remote from the unit.
Other controls to be specified separately see selection table.

PERFORMANCE - MARK TEN ROOF EXTRACT FANS

ELECTRICAL & SOUND

Curve	Code	Phase	RPM	Motor			Open inlet	Sound Power Levels (dB re 10 -12 W)						Open inlet Open outlet dBA @ 3m	Max Operating Temp °C			
				Power (kW)	FLC (amps)	SC (amps)		Octave band mid frequency (Hz)										
							Open inlet	63	125	250	500	1K	2K	4K	8K			
1	280MTD1/1	1	1200	0.015	0.19	0.66	induct inlet	65	65	61	49	50	54	48	41	40	39	
							open inlet	51	53	56	56	52	54	52	44			
							open outlet	53	60	55	45	47	49	43	33			40
2	400MT16/1	1	720	0.25	2	4.8	induct inlet	72	67	60	51	48	46	40	33	37	60	
							open inlet	60	59	56	50	48	46	40	33			40
							open outlet	60	59	56	50	48	46	40	32			40
3	315MTD1/1	1	1200	0.025	0.27	0.95	induct inlet	71	74	73	66	58	63	60	50	50	60	
							open inlet	68	67	63	63	61	59	54	45			50
							open outlet	59	69	67	61	55	58	54	42			50
4	400MT11/1	1	984	0.25	2	4.8	induct inlet	62	69	73	66	58	59	55	48	53	60	
							open inlet	50	61	69	65	58	59	55	48			53
							open outlet	50	61	69	65	58	59	55	47			53
5	400MTD9/1	1	1200	0.025	0.422	0.95	induct inlet	73	70	67	58	48	52	48	36	51	60	
							open inlet	61	62	63	57	48	52	48	36			51
							open outlet	61	62	63	57	48	52	48	35			51
6	400MT5/1	1	1284	0.25	2	4.8	induct inlet	64	78	76	63	66	64	59	54	56	60	
							open inlet	62	70	72	62	66	64	59	54			56
							open outlet	62	70	72	62	66	64	59	53			56
7	400MTD3/1	1	1420	0.58	1.32	7.02	induct inlet	75	78	78	69	70	68	64	58	56	60	
							open inlet	63	70	74	68	70	68	64	57			56
							open outlet	63	75	76	68	60	61	54	40			56
8	400MT1/1	1	1554	0.25	2	4.8	induct inlet	77	79	77	67	67	68	64	59	59	60	
							open inlet	65	71	73	66	67	68	64	59			59
							open outlet	65	71	73	66	67	68	64	58			59
9	500MT11/1	1	756	0.25	2	4.8	induct inlet	80	78	70	62	65	68	62	53	56	60	
							open inlet	68	70	66	62	65	68	62	53			56
							open outlet	68	70	66	62	65	68	62	53			56
10	500MTD9/1	1	910	0.025	2.1	6	induct inlet	79	82	71	68	66	63	57	45	51	40	
							open inlet	67	74	67	68	66	63	57	45			51
							open outlet	67	74	67	68	66	63	57	45			51
11	500MT8/1	1	1032	0.37	2.5	7.1	induct inlet	81	82	75	66	68	71	61	54	60	60	
							open inlet	69	74	71	66	68	71	61	54			60
							open outlet	69	74	71	66	68	71	61	54			60
12	500MTD1/1	1	1416	0.5	3.4	9.5	induct inlet	84	85	83	74	74	74	69	60	65	40	
							open inlet	72	77	79	74	74	74	69	60			65
							open outlet	72	77	79	74	74	74	69	60			65
13	630MT9/1	1	960	0.5	3.4	8.5	induct inlet	83	86	80	73	73	74	69	58	61	60	
							open inlet	71	78	76	73	73	74	69	58			61
							open outlet	71	76	76	73	73	73	74	69			61
14	400MT3/2	1	1464	0.18	0.65	2	induct inlet	86	88	85	80	78	78	73	63	69	48	
							open inlet	76	76	74	64	62	63	59	49			69
							open outlet	64	68	70	63	62	63	59	48			69
15	630MT2/2	3	1326	1.5	3.5	17	induct inlet	86	88	85	80	78	78	73	63	69	60	
							open inlet	74	80	81	80	78	78	73	63			69
							open outlet	74	80	81	80	78	78	73	63			69
16	630MTD1/2	3	1448	1.5	4.1	17	induct inlet	88	91	87	83	82	82	76	65	73	60	
							open inlet	76	83	83	83	82	82	76	65			73
							open outlet	76	83	83	83	82	82	76	65			73

Belt Drive models (printed on blue panels).

Code: 3 = 3 phase. The electrical and sound information in the table is nominal.

Start currents (sc) are DOL other than for motors of 4 kW and above which are star delta.

Mounting Angle: MTD up 80° except MTD 1000 and 1250 which is up to 10° MT up to 5° (because belt drive).

PERFORMANCE - MARK TEN ROOF EXTRACT FANS

Mark Ten Roof Extract Units 16-22

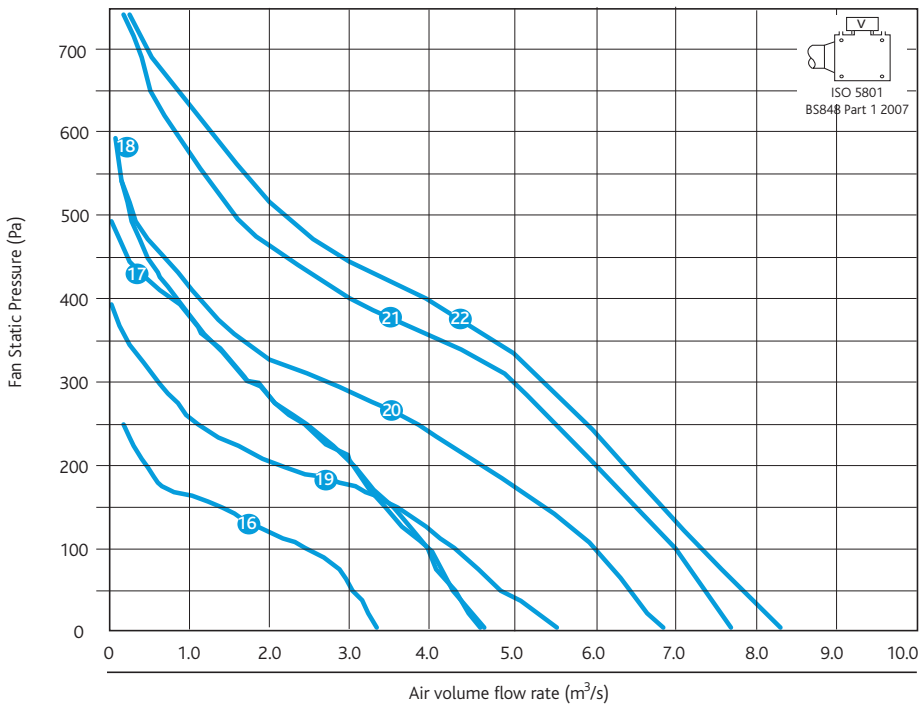

ELECTRICAL & SOUND

Curve	Code	Phase	RPM	Motor Power (kW)	FLC (amps)	SC (amps)	Open inlet Open outlet	Sound Power Levels (dB re 10 ⁻¹² W)								Open inlet Open outlet dBA @ 3m	Max Operating Temp °C
								Octave band mid frequency (Hz)									
								63	125	250	500	1K	2K	4K	8K		
16	800MT7/2	3	756	1.1	2.4	13	induct inlet	80	82	80	80	79	75	69	58	68	60
							open inlet	69	78	79	80	79	75	69	58		
							open outlet	69	78	79	80	79	75	69	58		
17	800MTD3/2	3	966	1.5	4.1	15.2	induct inlet	94	96	90	92	87	82	75	66	78	60
							open inlet	83	92	89	92	87	82	75	66		
							open outlet	83	92	89	92	87	82	75	66		
18	800MT1/2	3	1008	2.2	4.9	24.5	induct inlet	90	88	86	87	84	81	77	71	75	60
							open inlet	85	86	85	87	84	81	77	71		
							open outlet	85	86	85	87	84	81	77	71		
19	1000MT7/2	3	660	1.5	3.7	17	induct inlet	79	85	83	82	81	79	71	62	71	60
							open inlet	71	82	82	82	81	79	71	62		
							open outlet	71	82	82	82	81	79	71	62		
20	1000MT4/2	3	804	3	6.3	34.7	induct inlet	82	88	86	85	83	81	75	66	73	60
							open inlet	74	85	85	85	83	81	75	66		
							open outlet	74	85	85	85	83	81	75	66		
21	1000MTD2/2	3	960	4	12.4	47	induct inlet	94	96	93	91	91	87	83	84	81	78
							open inlet	90	95	93	91	91	87	83	74		
							open outlet	90	95	93	91	91	87	83	74		
22	1000MT1/2	3	972	5.5	11	40	induct inlet	85	91	90	90	87	85	78	69	75	60
							open inlet	77	88	89	90	87	85	78	69		
							open outlet	77	88	89	90	87	85	78	69		

Belt Drive models (printed on blue panels).

Code: 3 = 3 phase. The electrical and sound information in the table is nominal.

Start currents (sc) are DOL other than for motors of 4 kW and above which are star delta.

Mounting Angle: MTD up to 80° except MTD 1000 and 1250 which is up to 10° MT up to 5° (because belt drive).

MARK TEN UNIT DIMENSIONS (mm) WEIGHTS & QUICK SELECTION

Direct Drive Fan Unit	A	B	C	(Min Dims inside curb)		Weight Kg	Electronic Ecosmart Controls	Speed Controls	Auto-Inverter Controls	Drop-in transformer Controls	Drop-in Standard Attenuator	Long Attenuator	Roof Curb
				D	E								
224MTD1/1	362	292	199	125 sq	265 sq	4.0	-	NSC1-3A	N/A	SPCON1.5	-	-	224PFC/1
315MTD1/1	499	419	260	250 sq	385 sq	8.0	-	NSC1-3A	N/A	SPCON1.5	QC28S/1	-	280PFC/1
400MTD3/1	647	549	370	300 sq	490 sq	14.0	-	NSC1-3A	N/A	SPCON1.5	QC40S/1	QC40L/1	400PFC/1
400MTD3/2	647	549	370	300 sq	490 sq	14.5	-	NSC1-3A	N/A	SPCON1.5	QC40S/1	QC40L/1	400PFC/1
400MTD9/1	647	549	370	300 sq	490 sq	20.0	-	NSC1-3A	N/A	-	QC40S/1	QC40L/1	400PFC/1
500MTD1/1	749	649	447	400 sq	590 sq	29.0	-	NSC1-6A	N/A	SPCON75	QC50S/1	QC50L/1	500PFC/1
500MTD9/1	749	649	447	400 sq	590 sq	25.5	-	NSC1-3A	N/A	SPCON3.5	QC50S/1	QC50L/1	500PFC/1
630MTD1/2	853	756	573	500 sq	690 sq	45.0	ES-ISC5.6A	-	3ISC5.6A	-	QC63S/1	QC63L/1	630PFC/1
800MTD3/2	1150	1038	668	600 sq	790 sq	71.0	ES-ISC5.6A	-	3ISC5.6A	-	QC80S/1	QC80L/1	800PFC/1
1000MTD2/2	1402	1102	806	800 sq	1040 sq	134.0	ES-ISC12.5A	-	3ISC12.5A	-	QC100S/1	QC100L/1	1000PFC/1
Belt Drive													
400MT11/1	1100	615	373	300 sq	490 sq	35.5	-	-	-	-	QC40S/1	QC40L/1	400PFC/1
400MT16/1	1100	615	373	300 sq	490 sq	35.5	-	-	-	-	QC40S/1	QC40L/1	400PFC/1
400MT1/1	1100	615	373	300 sq	490 sq	35.5	-	-	-	-	QC40S/1	QC40L/1	400PFC/1
400MT5/1	1100	615	373	300 sq	490 sq	35.5	-	-	-	-	QC40S/1	QC40L/1	400PFC/1
500MT8/1	1350	784	518	400 sq	590 sq	45.0	-	-	-	-	QC50S/1	QC50L/1	500PFC/1
500MT11/1	1350	784	518	400 sq	590 sq	40.0	-	-	-	-	QC50S/1	QC50L/1	500PFC/1
630MT2/2	1350	784	518	500 sq	690 sq	67.0	ES-ISC5.6A	-	3ISC5.6A	-	QC63S/1	QC63L/1	630PFC/1
630MT9/1	1350	784	518	500 sq	690 sq	62.0	-	-	-	-	QC63S/1	QC63L/1	630PFC/1
800MT1/2	1735	890	610	600 sq	790 sq	121.0	ES-ISC5.6A	-	3ISC5.6A	-	QC80S/1	QC80L/1	800PFC/1
800MT7/2	1735	890	610	600 sq	790 sq	113.0	ES-ISC3.3A	-	3ISC3.3A	-	QC80S/1	QC80L/1	800PFC/1
1000MT1/2	1967	1125	693	800 sq	1040 sq	212.0	ES-ISC12.5A	-	3ISC12.5A	-	QC100S/1	QC100L/1	1000PFC/1
1000MT4/2	1967	1125	693	800 sq	1040 sq	182.0	ES-ISC12.5A	-	3ISC12.5A	-	QC100S/1	QC100L/1	1000PFC/1
1000MT7/2	1967	1125	693	800 sq	1040 sq	172.0	ES-ISC4.1A	-	3ISC4.1A	-	QC100S/1	QC100L/1	1000PFC/1

Mounting Angle: MTD up 80° except MTD 1000 and 1250 which is up to 10° MT up to 5° (because belt drive).

DROP-IN SILENCER DIMENSIONS (mm) & WEIGHTS

Mark Ten Unit	Unit Code	Type	A	B	C	No. of Holes	Weight Kg	Z	
280/315	QC28S/1	Standard	306	230	500	8	8.3	2666	
400	QC40S/1	Standard	356	280	600	8	16	306	
500	QC50S/1	Standard	456	380	670	12	30	94	
630	QC63S/1	Standard	556	480	825	16	46	66	
800	QC80S/1	Standard	656	580	720	16	53	66	
1000	QC100S/1	Standard	856	780	720	24	66	12.5	
Frequency Hz			125	250	500	1K	2K	4K	8K
Dynamic Attenuation (dB)			5	8	13	20	21	18	14
280/315	QC28L/1	Long	306	230	950	8	12.3	2666	
1400	QC40L/1	Long	356	280	1050	8	21	306	
1500	QC50L/1	Long	456	380	1120	12	40	94	
1630	QC63L/1	Long	556	480	1275	16	74	66	
1800	QC80L/1	Long	656	580	1170	16	85	66	
11000	QC100L/1	Long	856	780	1170	24	104	12.5	
Frequency Hz			125	250	500	1K	2K	4K	8K
Dynamic Attenuation (dB)			10	16	26	40	40	35	26

MARK TEN UNIT DIMENSIONS

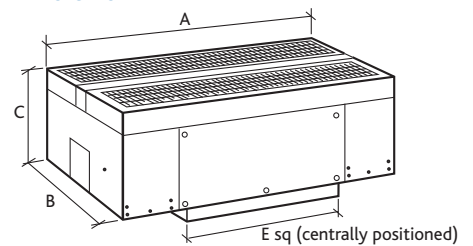

DROP-IN SILENCER DIMENSIONS

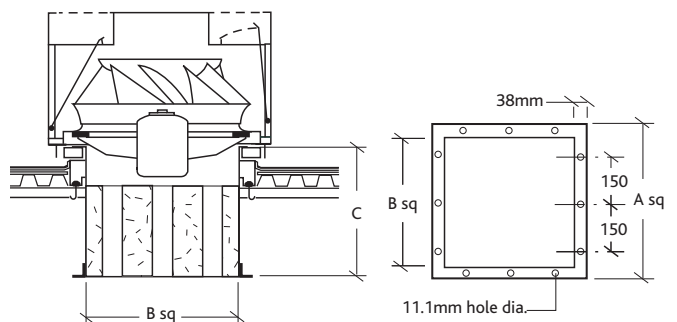

Note: Air Pressure Drop of Attenuator (Pa) = Z x Q2
 where Z = Factor listed in table
 Q = Air Volume Flow Rate (m³/s)

WIRING - MARK TEN BELT DRIVE (SINGLE PHASE UNITS - 2 WIRE SUPPLY)

1 Phase Single Speed

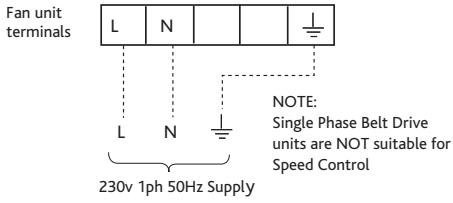

3 Phase Single Speed (below 4kW)

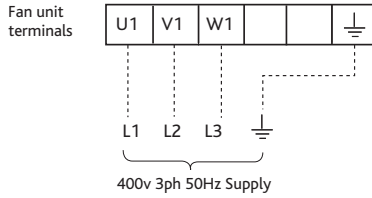

3 Phase DOL Starting and Connection to Frequency Inverter (4kW and above)

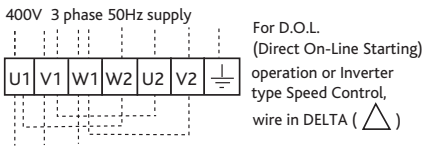

3 Phase for Connection to Star/Delta starter (4kW and above)

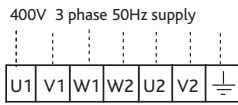

2 Speed TAP/PAM Wound Motor (DOL starting both speeds)

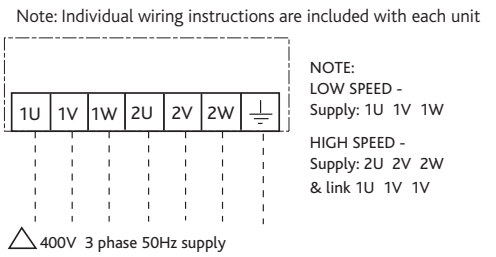

Ecosmart

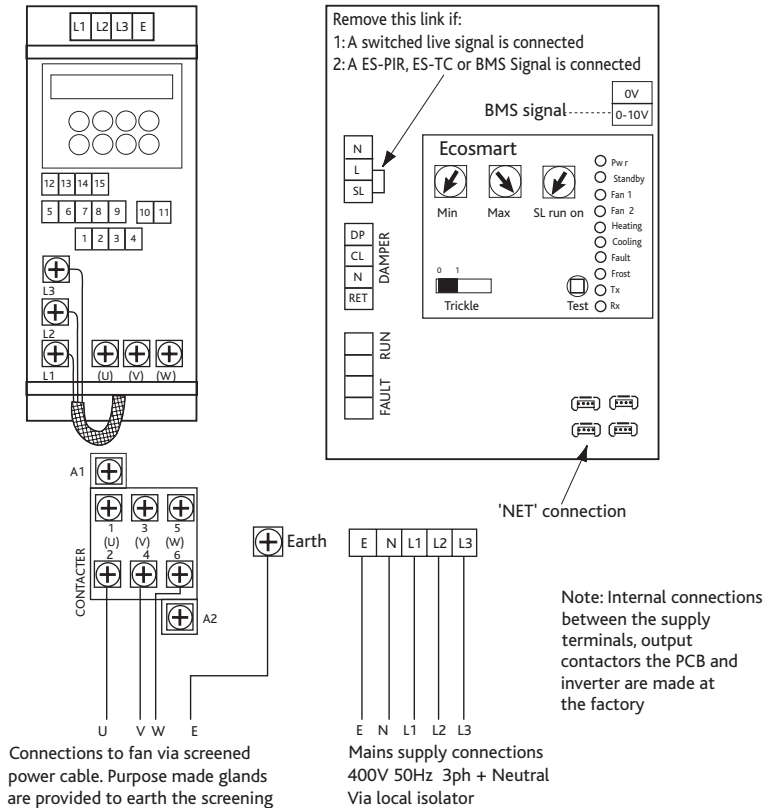

MARK TEN WIRING CONT.

WIRING - MARK TEN DIRECT DRIVE (SINGLE PHASE UNITS - 2 WIRE SUPPLY)

Single Speed 1 Phase MTD only

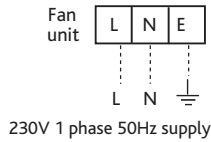

Single Speed 1 Phase

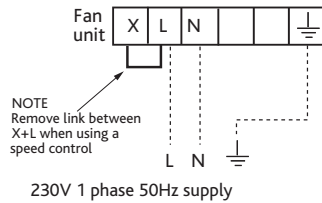

Single Speed 3 Phase (below 4kW)

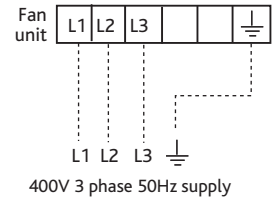

Transformer Speed Control 1 Phase

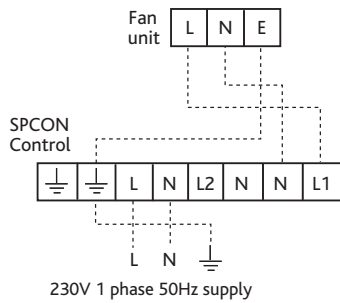

(Single phase units - 3 wire supply)
Electronic Speed Control 1 Phase

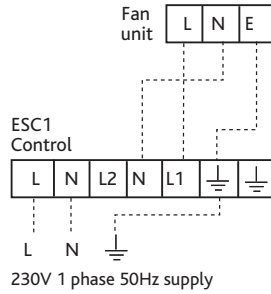

Electronic Speed Control 1 Phase

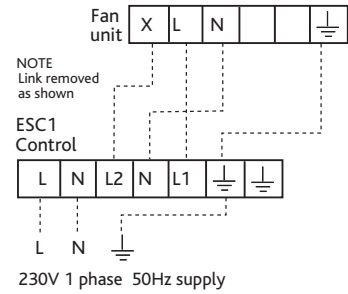

2 Speed Motors (DOL starting both speeds) Transformer Speed Control 1 Phase

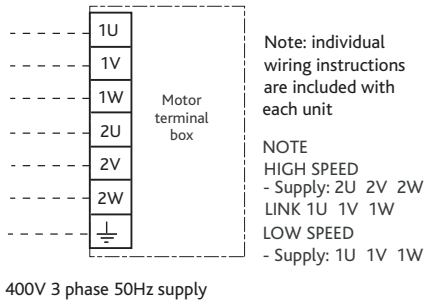

Transformer Speed Control 1 Phase

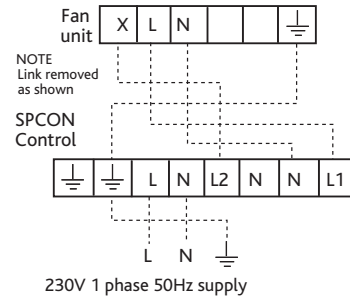

3 Phase for Star/Delta Starting (4kW & above) Matched Nuair Inverter Speed Control

Note:
For D.O.L (Direct On Line) operation or
Inverter type Speed Control, wire in DELTA (Δ)

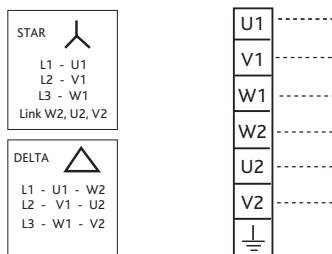

400V 3 phase 50Hz supply

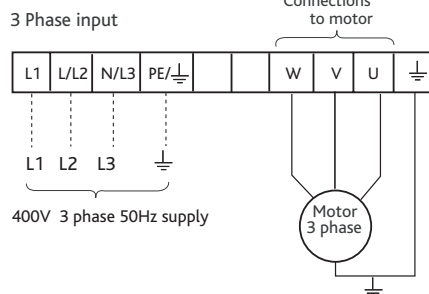

3 Phase only
INVERTER SPEED CONTROL

Notes:
Total length of motor leads should not exceed 50 metres.
If a screened motor cable is used, maximum length should be 25 metres. Consult our Technical Department if you wish to use longer leads.
Inverters are configured to suit specific fans and control applications as described on the Customer Order free of charge.

CONTROLS

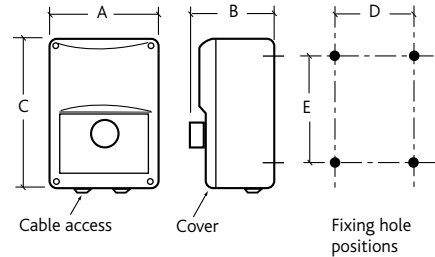
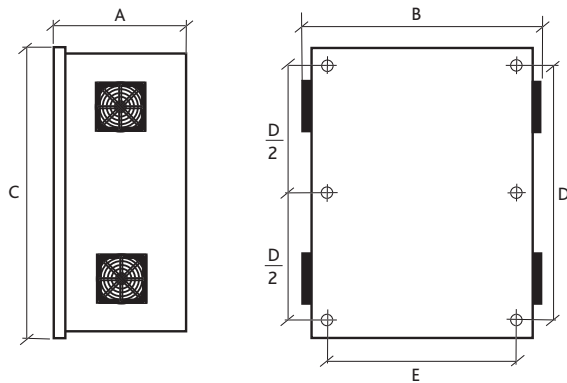

ECOSMART CONTROL (mm)

Fan Code	A mm	B mm	C mm	Weight Kg	Drill	Pattern
ES-ISC1.2A	230	325	410	6	340	298
ES-ISC2.14A	230	325	410	6	340	298
ES-ISC3.3A	230	325	410	6	340	298
ES-ISC4.1A	230	325	410	6	340	298
ES-ISC5.6A	290	390	455	14	470	373
ES-ISC7.3A	290	390	455	14	470	373
ES-ISC8.8A	290	390	455	14	470	373
ES-ISC12.5A	290	390	455	20	470	373
ES-ISC15.6A	290	390	455	20	470	373
ES-ISC23.1A	290	390	455	20	470	373
ES-ISC38.0A	355	525	805	40	710	513

ELECTRONIC SPEED CONTROL (mm)

Unit Code	A	B	C	D	E	Weight Kg
NSC1-3A	83	88	180	71	108	0.5
NSC1-6A	115	95	195	98	140	0.7
NSC1-10A	115	95	195	98	140	0.7

The electronic speed controllers provide infinitely variable speed control from preset minimum to maximum. All models feature a boost start function, which applies maximum power to the motor for a few seconds to prevent motor stalling before returning to selected speed. Wiring to the motor can be either 2-wires or 3-wires control depending on the motor design. The enclosures for ESC1-3A and ESC1-6A are rated to IP45 with the ESC1-10A rated at IP54. All controllers meet LVD and EMC directives for safety and electromagnetic compatibility.

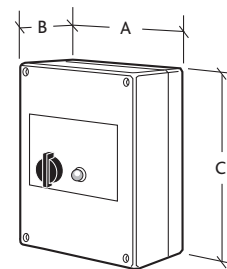

TRANSFORMER SPEED CONTROL (mm)

Single Phase					
Unit Code	A	B	C	Weight Kg	
SPCON1.5	115	85	180	1.7	
SPCON3.5	200	140	280	3.6	
SPCON7.5	200	140	280	6	

Autotransformers having class 'F' insulation are used to provide discrete voltage steps. All models are fitted with suitable fuses for short-circuit protection. The controller casing is manufactured from plastic pre-coated steel or impact resistant polycarbonate. All models are suitable for indoor installations only. All controllers meet LVD and EMC directives for safety and electromagnetic compatibility. Transformer speed controls produce a pure sine wave output resulting in quiet motor operation. Transformer controls are therefore preferred for noise sensitive applications.

INVERTER SPEED CONTROL

DIMENSIONS (MM)

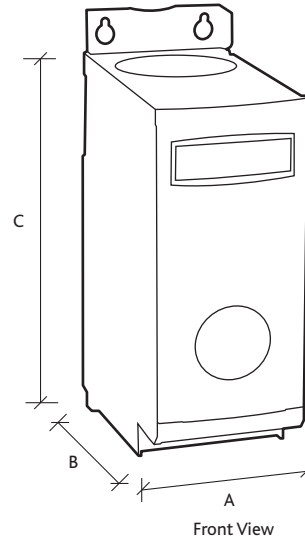

These are a range of frequency inverters for controlling the speed of 3 phase AC motors. Standard range are 400V 3 phase input units covering motor rating from 0.75kW to kW. Higher ratings and single phase input models are available upon request.

The inverters are microprocessor controlled and use state of the art Insulated Gate Bipolar Transistor (IGBT) technology. This makes them reliable and versatile. A special pulse-width modulation method with selectable pulse frequency permits quiet motor operation.

Comprehensive protective functions provide excellent inverter and motor protection.

The inverters default factory settings, is ideal for a large range of simple motor control applications. The inverters can also be used for more advanced motor control applications via its comprehensive parameter lists. The inverters can be used in both 'stand alone' applications as well as being integrated into 'Automation systems'.

Fan code	Motor Kw	A	B	C	Weight Kg
3ISC1.2A	0.37	70	142	280	1.5
3ISC1.9A	0.35	70	142	280	1.5
3ISC2.4A	0.75	70	142	280	1.7
3ISC3.3A	1.1	70	142	280	1.7
3ISC4.1A	1.5	70	142	280	1.7
3ISC5.6A	2.2	70	142	280	1.7
3ISC7.3A	3	70	142	280	1.7
3ISC8.8A	4	70	142	280	1.7
3ISC12.5A	5.5	169	177	299	3.5
3ISC15.6A	7.5	169	177	299	3.5
3ISC23.1A	11	169	177	299	3.5
3ISC31.0A	15	260	177	320	5
3ISC38.0A	18.5	260	177	320	5
3ISC44.0A	22	260	177	320	5
3ISC59.0A	30	260	177	320	24
3ISC72.0A	37	260	177	320	24
3ISC87.0A	45	260	177	320	24

Code descriptions

3 ISC 1.2A

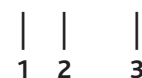

- 1. 3 Phase supply
- 2. Inverter Speed Control
- 3. Output Current Rating

CONSULTANTS SPECIFICATION

FAN DESCRIPTION

The Roof mounted extract fan/s shall be located in the positions indicated on the drawings and in accordance with the relevant fan schedule. It shall be a low profile cowl manufactured in aluminium alloy, colour to be confirmed.

The fan shall be of the MARK TEN vertical discharge type and shall be supplied complete with backdraught shutters, birdguard, purlin box curb, hand guard and soaker sheet, specific details of the curb to be confirmed by the main contractor. The mechanical contractor shall make due allowance for supporting the fan via the provision of purpose made trimmers between purlin. The trimmers shall be sized to adequately support the weight of the fans.

The direct drive units can be mounted up to an angle of 80 degrees, except for the 1000 which cannot be mounted at an angle greater than 10 degrees.

The belt drive units can not be mounted at an angle greater than 5 degrees.

The unit and ancillaries shall be supplied with a 3 years manufacturer's warranty, first year parts and labour the remainder parts only. Ecosmart Ecosmart Mark ten shall have a 5 year warranty, first year parts and labour the remainder parts only.

The unit and ancillaries shall be of the Mark Ten type as manufactured by Nuair Ltd.

CONTROL SPECIFICATION

The fan unit can be supplied with one of the following control options:-

1. ECOSMART CONTROLS

- The compact Ecosmart control system complete with all necessary controls to facilitate the operation of the ventilation system. It shall be complete with an integral factory fitted Ecosmart PCB which will control the fan unit within the desired design parameters and provide the interface between all external control devices and the unit itself.

The fan unit shall have the following energy saving components integrally mounted, pre-wired to interface with the purpose made PCB, all components pre-wired, configured and factory fitted by the manufacturer: -

- Integral Frequency inverter/speed controller.
- Integral maximum and minimum speed adjustment for commissioning.
- Integral adjustable run on timer.
- Integral BMS interfaces – 0-10V speed adjustment.
- Integral BMS interfaces – Volt free failure and status indication.
- Integral background ventilation switch (trickle switch).
- Multiple IDC sockets for interconnection of sensors or fans using pre-plugged 4-core low voltage cable.

ECOSMART SYSTEM OPERATION

The Ecosmart controls will enable the unit to automatically vary its speed as it receives signals from one of the interconnected sensors. When the signal is received the fan shall either increase speed gradually until the required level is achieved or it will work on a trickle and boost principle. This will then move the fan duty point from trickle/background ventilation rate to the required boost ventilation rate. Both the trickle and boost rates are infinitely variable, easy to adjust and remove the need of a main balancing damper.

2. BMS INTERFACES

The fan unit shall be provided with the following integrated BMS interfaces:

1. 0 - 10 volt contacts to provide a full BMS interface. This will enable the following functions:-
 - Switch the unit on/off.
 - Switch from low speed to high speed.
 - Full speed control facility.
2. 2 Volt free contacts to provide fan run and failure indication to provide system status.
3. An integrated commissioning/speed control to accurately commission the system, with minimum and maximum speeds easily adjusted via a miniature dial, as recommended in Part L. This will enable the unit to be configured to run between set parameters thus saving motor power and limiting noise.
4. Commissioning set up - The fan unit shall be provided with an integrated commissioning/speed control to accurately commission the system, as recommended in Part L, minimum and maximum speeds easily adjusted via miniature dial. The commissioning set up facility directly controls the integrated speed control/frequency inverter.

3. STANDARD CONTROLS

The unit shall be provided with a standard speed control or starter in accordance with the manufacturer's recommendations.

Mark Ten has a 3 year warranty.

Ecosmart Mark Ten has a 5 year warranty.

All equipment shall be as manufactured by Nuair Ltd.