

## SQUIF HIGH TEMPERATURE FANS

HIGH TEMPERATURE CENTRIFUGAL SQUIF FOR SMOKE EXTRACT  
CERTIFIED TO EN12101-3-2002.



## BENEFITS

### HIGH TEMPERATURE APPLICATION

Capable of running continuously at 90°C, ideal for kitchen canopy applications with a one off 400°C for 2 hours.

### QUIET OPERATION

One of the quietest solutions for motor unit out of airstream applications.

### EASY MAINTENANCE

'Out of air stream' allows for quick and easy access and lower maintenance costs.

### IDEAL FOR HIGH RESISTANCES

High pressure development suitable for ducted systems.

### FLEXIBLE SOLUTION

Can be mounted internally, externally, vertically or horizontally.

### FAN TO SUIT ALL APPLICATIONS

2-speed motors available for day to day extract and smoke extract.

### SAFETY TESTED

Fans are tested to comply to EN12101-3 2002.

### WARRANTY

High temperature Squif has a 3 year warranty.

**Note: only suitable for outside smoke reservoir applications.**

## SQUIF ANCILLARIES

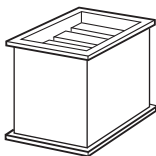

Splitter Attenuator.

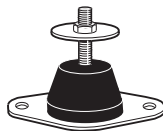

AV Mounts.

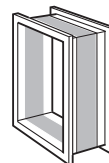

Flexible Connector.

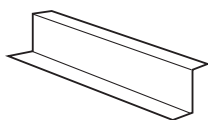

Feet built in.

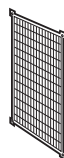

Guard for square units.

## CONTROLS

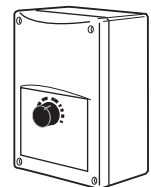

Electronic Speed Control.

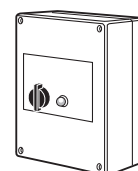

Transformer Speed Control.

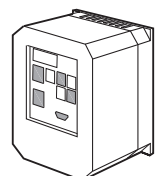

Inverter Speed Control.

**PERFORMANCE - SQUIF HIGH TEMPERATURE FANS**

**Squif - 4 pole**

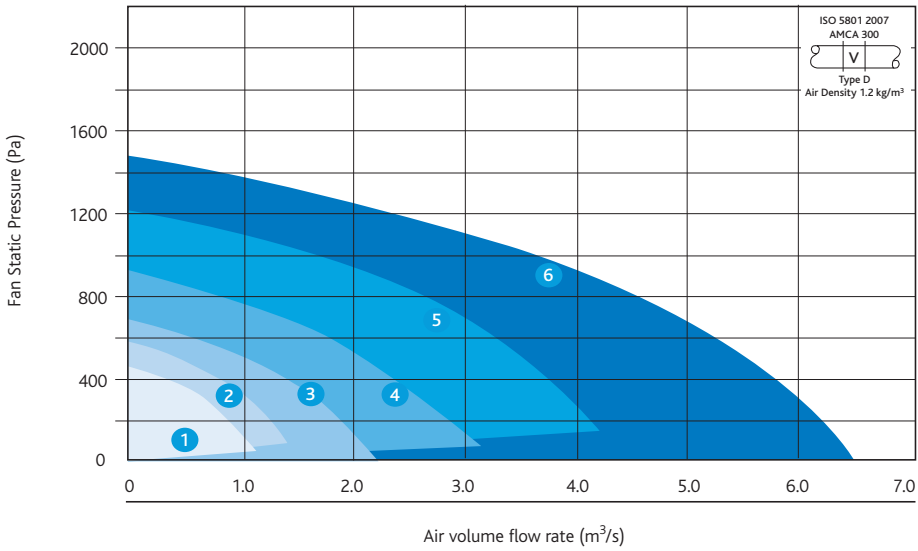

**Casing**

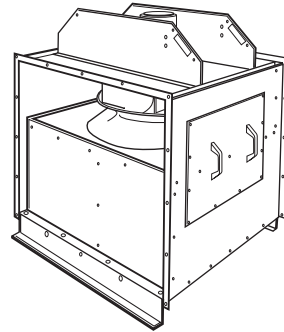

**Code descriptions**

**SQF 4 1 - 3**

1	2	3	4

- 1. Squif range
- 2. Pole (4 or 6)
- 3. Curve No.
- 4. Phase (1 or 3)

**Squif - 6 pole**

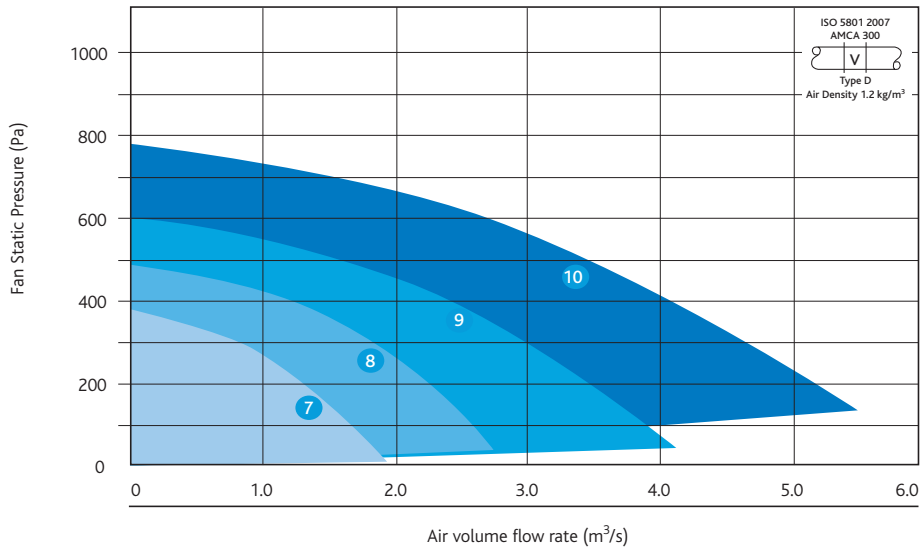

**SQUIF**

**ELECTRICAL & SOUND**

Curve	Code	Phase	RPM	Motor Power (kW)	FLC (amps)	SC (amps)	SC ★/▲	Data Type	Sound Power Levels (dB re 1pW)							dBA @ 3m
									Octave band mid frequency (Hz)							
									125	250	500	1K	2K	4K	8K	
1	SQF 41-3	3	1450	0.37	1.1	5.2	-	I	90	79	70	70	70	69	62	50
	SQF 41-1	1	1410	0.37	2.8	11.2		O	91	74	68	74	75	70	64	
2	SQF 42-3	3	1450	0.75	2	9.0	-	I	92	82	77	74	76	75	67	53
3	SQF 43-3	3	1450	1.1	2.5	12	-	I	95	83	79	77	78	78	71	56
	SQF 43-1	1	1420	1.1	7	35		O	96	79	77	82	83	79	73	
4	SQF 44	3	1450	2.2	4.8	12	-	I	93	89	82	77	80	80	71	58
								O	87	86	87	81	82	82	68	
5	SQF 45	3	1450	4	8.3	45	15	I	99	87	85	85	84	83	81	62
								O	100	83	82	89	89	84	83	
6	SQF 46	3	1450	7.5	15.2	108	36	I	103	92	86	86	85	86	83	63
								O	92	90	91	89	87	87	81	
7	SQF 61	3	960	0.75	2.1	8.82	-	I	89	84	75	70	73	73	64	47
								O	83	81	80	74	75	75	61	
8	SQF 62	3	960	1.1	3	13.2	-	I	96	83	78	76	75	74	72	56
								O	97	78	76	80	79	75	74	
9	SQF 63	3	960	2.2	5.9	28.9	-	I	100	87	79	76	76	77	73	59
								O	101	82	77	80	80	78	75	
10	SQF 64	3	960	4	9.4	63	20.4	I	103	91	82	79	77	77	74	62
								O	104	86	80	83	82	78	76	

The electrical and sound information in the table is nominal. Breakout dBA@3m is spherical, free field. Start currents (sc) are DOL 1 = 1 phase (230 Volt, 50Hz) 3 = 3 phase (400 Volt, 50Hz). SC★/▲ = star delta starting current.

**QUICK SELECTION GUIDE**

**SQUIF HIGH TEMPERATURE**

Fan unit	Standard silencers	Long silencers	Flexible Connectors	Fan Guards	AV Mounts
SQF41-3	SQFS1S	SQFS1L	SQFF1	SQFGD1	NAV2
SQF41-1	SQFS1S	SQFS1L	SQFF1	SQFGD1	NAV2
SQF42-3	SQFS2S	SQFS2L	SQFF2	SQFGD2	NAV2
SQF43-3	SQFS3S	SQFS3L	SQFF3	SQFGD3	NAV2
SQF43-1	SQFS3S	SQFS3L	SQFF3	SQFGD3	NAV2
SQF44	SQFS4S	SQFS4L	SQFF4	SQFGD4	NAV5
SQF45	SQFS4S	SQFS4L	SQFF5	SQFGD5	NAV5
SQF46	SQFS5S	SQFS5L	SQFF6	SQFGD6	NAV3
SQF61	SQFS5S	SQFS5L	SQFF4	SQFGD4	NAV3
SQF62	SQFS6S	SQFS6L	SQFF5	SQFGD5	NAV4
SQF63	SQFS7S	SQFS7L	SQFF6	SQFGD6	NAV4
SQF64	SQFS8S	SQFS8L	SQFF7	SQFGD7	NAV6

**DIMENSIONS**

**SQUIF DIMENSIONS (mm) & WEIGHTS**

Unit size	A	B	C	D	E	F	G	H	M	Weight (Kg)
SQF 41-3	634	500	500	532	532	26.5	273	227	193	52
SQF 41-1	634	500	500	532	532	26.5	273	227	193	52
SQF 42-3	692	700	600	730	630	32	382	318	215	60
SQF 43-3	750	750	650	780	680	32	412	338	231	70
SQF 43-1	750	750	650	780	680	32	412	338	231	70
SQF 44	820	800	700	830	730	32	440	360	290	100
SQF 61	820	800	700	830	730	32	440	360	290	100
SQF 45	901	900	800	930	830	32	490	410	290	150
SQF 62	901	900	800	930	830	32	490	410	290	150
SQF 46	994	1000	900	1030	930	32	546	454	387	255
SQF 63	994	1000	900	1030	930	32	546	454	387	255
SQF 64	1114	1100	1000	1130	1030	32	600	500	387	315

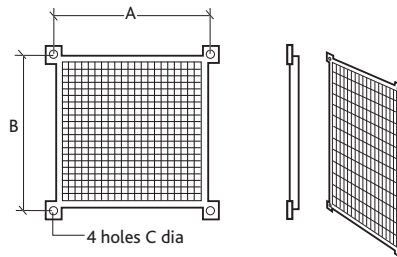
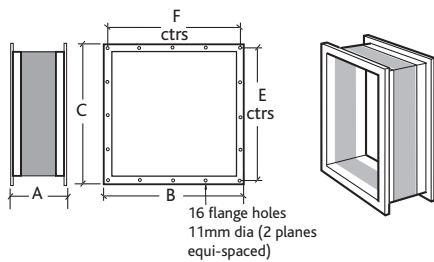
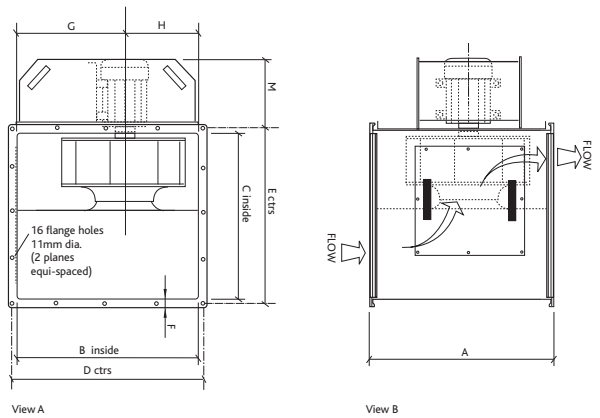
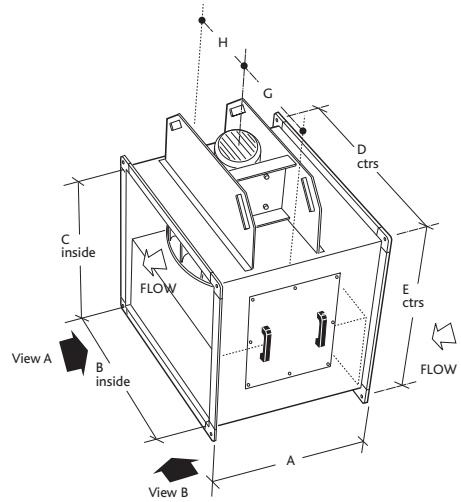

**ANCILLARIES FOR SQUIF UNITS**

**DOUBLE FLANGED FLEXIBLE CONNECTOR**

Flexible duct material is flame proof. Heat resistance is 400°C with excellent resistance to chemicals, ozone, oil and grease. The connector is air-tight, waterproof and tested to BS476 Part 7.

Dimensions (mm)						
Code	Squif Fan	A	B	C	F	E
SQFF 1	SQF41-3 SQF41-1	150	560	560	532	532
SQFF 2	SQF42-3	150	760	660	730	630
SQFF 3	SQF43-3 SQF43-1	150	810	710	780	680
SQFF 4	SQF44 SQF61	150	860	760	830	730
SQFF 5	SQF45 SQF62	150	980	880	930	830
SQFF 6	SQF46 SQF63	150	1080	980	1030	930
SQFF 7	SQF64	150	1180	1080	1130	1030

**GUARD FOR SQUARE FANS**

Manufactured from galvanised steel wire or polyester coated mild steel. Resistance to airflow is negligible.

Dimensions (mm)				
Code	Squif Fan	A	B	C
SQFGD 1	SQF41-3 SQF41-1	532	532	11
SQFGD 2	SQF42-3	730	630	13
SQFGD 3	SQF43-3 SQF43-1	780	680	13
SQFGD 4	SQF44 SQF61	830	730	13
SQFGD 5	SQF45 SQF62	930	830	13
SQFGD 6	SQF46 SQF63	1030	930	13
SQFGD 7	SQF64	1130	1030	13

For details on Melinex silencer's please contact Nuair.

**ANCILLARIES FOR SQUIF HIGH TEMPERATURE UNITS CONT.**

**Silencers**

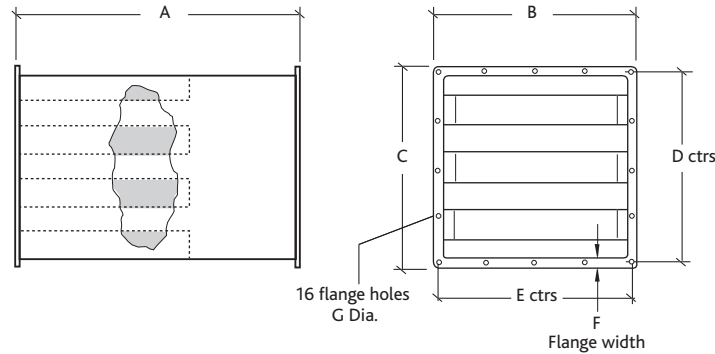

**LONG SILENCERS DIMENSIONS (mm) & WEIGHTS**

Matching Unit	Attenuator Code	Airflow m <sup>3</sup> /s	Dynamic insertion loss (db)							Dimensions							Weight Kg	Z
			125	250	500	1K	2K	4K	8K	A	B	C	D	E	F	G		
SQF 41-3	SQFS1L	0-1.1	-8	-12	-32	-42	-33	-32	-18	1200	560	560	532	532	26.5	11	38	36.8
SQF 41-1	SQFS1L	0-1.1	-8	-12	-32	-42	-33	-32	-18	1200	560	560	532	532	26.5	11	38	36.8
SQF 42-3	SQFS2L	0-1.6	-8	-12	-32	-42	-33	-32	-18	1200	760	660	630	730	32	11	43	30.5
SQF 43-3	SQFS3L	0-2.2	-8	-12	-32	-42	-33	-32	-18	1200	810	710	680	780	32	11	46	30.5
SQF 43-1	SQFS3L	0-2.2	-8	-12	-32	-42	-33	-32	-18	1200	810	710	680	780	32	11	46	30.5
SQF 44	SQFS4L	0-3.1	-8	-12	-32	-42	-33	-32	-18	1200	860	760	730	830	32	11	60	10.9
SQF 61	SQFS4L	0-1.9	-8	-12	-32	-42	-33	-32	-18	1200	860	760	730	830	32	11	60	10.9
SQF 45	SQFS5L	0-4.3	-8	-12	-32	-42	-33	-32	-18	1200	980	880	830	930	32	12.5	91	5.47
SQF 62	SQFS5L	0-2.7	-8	-12	-32	-42	-33	-32	-18	1200	980	880	830	930	32	12.5	91	5.47
SQF 46	SQFS6L	0-6.5	-8	-12	-32	-42	-33	-32	-18	1200	1080	980	930	1030	32	12.5	98	5.47
SQF 63	SQFS7L	0-4.2	-8	-12	-32	-42	-33	-32	-18	1200	1080	980	930	1030	32	12.5	116	1.54
SQF 64	SQFS8L	0-6	-8	-12	-32	-42	-33	-32	-18	1200	1180	1080	1030	1130	32	12.5	122	1.54

**SHORT SILENCERS DIMENSIONS (mm) & WEIGHTS**

Matching Unit	Attenuator Code	Airflow m <sup>3</sup> /s	Dynamic insertion loss (db)							Dimensions							Weight Kg	Z
			125	250	500	1K	2K	4K	8K	A	B	C	D	E	F	G		
SQF 41-3	SQFS1S	0-1.1	-4	-8	-18	-24	-19	-16	-11	900	560	560	532	532	26.5	11	15	36.8
SQF 41-1	SQFS1S	0-1.1	-4	-8	-18	-24	-19	-16	-11	900	560	560	532	532	26.5	11	15	36.8
SQF 42-3	SQFS2S	0-1.6	-4	-8	-18	-24	-19	-16	-11	900	760	660	630	730	32	11	29	30.5
SQF 43-3	SQFS3S	0-2.2	-4	-8	-18	-24	-19	-16	-11	900	810	710	680	780	32	11	32	30.5
SQF 43-1	SQFS3S	0-2.2	-4	-8	-18	-24	-19	-16	-11	900	810	710	680	780	32	11	32	30.5
SQF 44	SQFS4S	0-3.1	-4	-8	-18	-24	-19	-16	-11	900	860	760	730	830	32	11	42	10.9
SQF 61	SQFS4S	0-1.9	-4	-8	-18	-24	-19	-16	-11	900	860	760	730	830	32	11	42	10.9
SQF 45	SQFS5S	0-4.3	-4	-8	-18	-24	-19	-16	-11	900	980	880	830	930	32	12.5	61	5.47
SQF 62	SQFS5S	0-2.7	-4	-8	-18	-24	-19	-16	-11	900	980	880	830	930	32	12.5	61	5.47
SQF 46	SQFS6S	0-6.5	-4	-8	-18	-24	-19	-16	-11	900	1080	980	930	1030	32	12.5	68	5.47
SQF 63	SQFS7S	0-4.2	-4	-8	-18	-24	-19	-16	-11	900	1080	980	930	1030	32	12.5	81	1.54
SQF 64	SQFS8S	0-6	-4	-8	-18	-24	-19	-16	-11	900	1180	1080	1030	1130	32	12.5	86	1.54

Note: Air Pressure Drop of Attenuator (Pa) = Z x Q<sup>2</sup> where Z = Factor listed in table above Q = Air Volume Flow Rate (m<sup>3</sup>/s).

WIRING - SQUIF

Single phase single speed

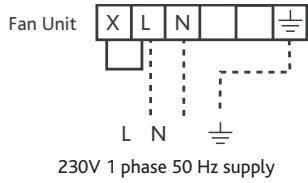

Three phase motors are connected directly to the Motor Terminal Box

3 phase units up to 3KW

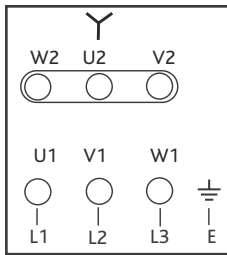

3 phase units 4KW and above

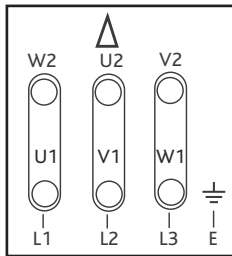

**Important:** when the unit is operated in emergency mode, smoke extract operation, all controls must be bypassed to comply with EN12101-3 certification of the unit.

Two speed motors DOL starting on both speeds

Observe the motor plate and connection details.  
 3 phase two speed tap/pam wound motors require a three contactor control.  
 3 phase Dual wound motors require a two contactor control.

Motor Terminal Box

Note: HIGH SPEED -  
 Supply 2U 2V 2W  
 Link 1U 1V 1W  
 LOW SPEED  
 Supply 1U 1V 1W

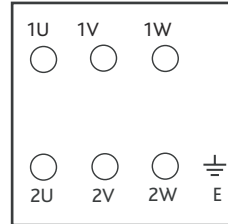

400V 3 phase 50Hz supply

3 phase units with matched frequency inverter

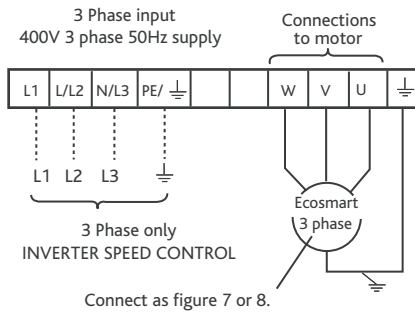

Notes:  
 Total length of motor leads should not exceed 50 mtrs.  
 If a screened motor cable is used, maximum length should be 25 mtrs.  
 Consult our Technical Department if you wish to use longer leads.  
 Inverters are configured to suit specific fans and control applications as described on the Customer Order.

## CONSULTANTS SPECIFICATION

### SYSTEM SPECIFICATION

The SMOKE EXTRACT fan Unit shall be configured and arranged as detailed on the drawings and in accordance with the schedule of equipment and shall be of the SQUIF type as manufactured by Nuaire. The units shall be manufactured in heavy gauge Aluzinc corrosion resistant steel. The general construction is to class A leakage.

The fan impeller and motor shall be selected to provide the most energy efficient solution conforming to part L regulations and shall be direct drive with IE2 high efficiency motors to BS5000 as standard.

The fan impeller shall be a high efficiency backward curved centrifugal design, manufactured in galvanised steel and the motor shall be positioned outside the ventilation airflow path. It shall provide excellent in duct and breakout noise levels.

The unit shall be capable of continuous operation at 90°C and a one off operation at up to 400°C for a period of 2 hrs certified to EN12101-3. The unit has been independently tested for high temperature operation by BSRIA and certified by BSI. This shall be achieved using a standard non temperature rated motor. The unit is only suitable for non-smoke reservoir applications.

A two speed version of the unit to be provided where specified and controlled in accordance with the specification and manufacturers recommendations.

The unit shall be supplied with all necessary ancillaries as recommended by the manufacturer and in accordance with the equipment schedule.

The contractor shall allow for all necessary ductwork transformations to and from the fan unit and any associated components in accordance with the manufacturers recommendations, DW144 and general good practice.

The unit and ancillaries shall be supplied with a 3 year warranty.

The unit shall be of the SQUIF type as manufactured by Nuaire Ltd.